

# SVP-S 5x

## Mounting instructions

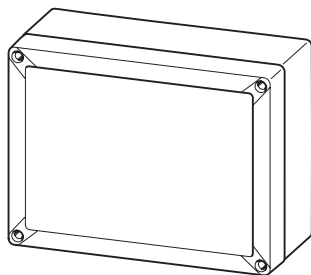

SVP-S 53

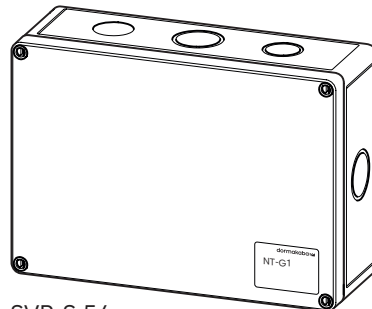

SVP-S 54

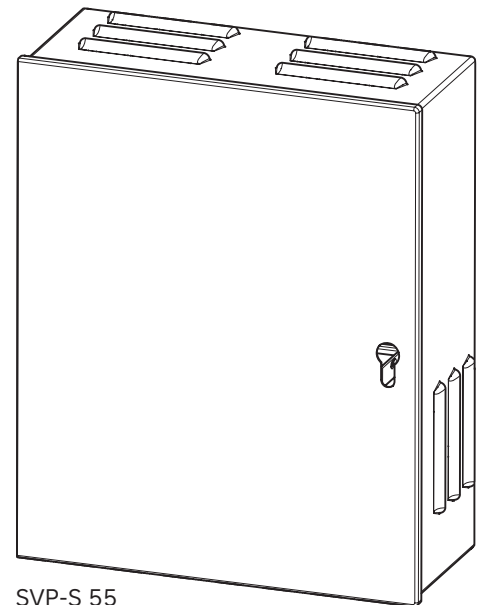

SVP-S 55

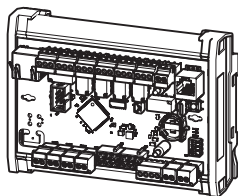

SVP-S 56

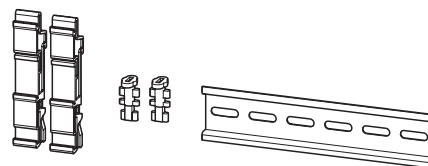

SVP-S 4/5

## Table of contents

<b>1</b>	<b>About this document</b>	<b>2</b>
1.1	Contents and purpose	2
1.2	Target group	2
1.3	Documents storage	2
1.4	Symbols used	2
<b>2</b>	<b>Safety</b>	<b>3</b>
2.1	Intended use	3
2.2	Personnel qualification	3
<b>3</b>	<b>Product description</b>	<b>3</b>
3.1	Technical data	3
<b>4</b>	<b>Mounting</b>	<b>4</b>
4.1	Mounting preparation	4
4.2	SVP-S 53 mounting	4
4.3	SVP-S 54 mounting	5
4.4	SVP-S 55 mounting	6
4.5	SVP-S 56 mounting with SVP-S 4/5 conversion kit	7
4.6	Optional parts	8
<b>5</b>	<b>Connection</b>	<b>9</b>
5.1	Layout of terminals and switches	9
5.1.1	Power supply	9
5.1.2	CR1220 battery	9
5.1.3	LED display	9
5.1.4	Service button	9
5.1.5	DIP switch	9
5.2	SVP-S 5x with SVP/SVA 2xxx (F)	10
5.3	SVP-S 5x with SVP/SVA 2xxx and external PR module	11
5.4	SVP-S 5x with. SVP/SVA 4xxx	12
5.5	SVP-S 5x with SVP/SVA 6xxx	13
5.6	SVP-S 5x with M-SVP 2xxx /22xx	14
5.7	SVP-S 5x with SVA 2xxx (F) and SVI 2xxx	15
5.8	SVP-S 5x with SVA/SVI (ED100 / ED250 control)	16
5.9	DCW® key switch default functions	17
5.9.1	Address 1	17
5.9.2	Address 2	17
5.9.3	Address 3	17
5.9.4	Address 4	17
5.9.5	External I/O modules	17
<b>6</b>	<b>Commissioning</b>	<b>17</b>
<b>7</b>	<b>Firmware update</b>	<b>17</b>
<b>8</b>	<b>Error codes</b>	<b>18</b>
<b>9</b>	<b>Disassembly and disposal</b>	<b>19</b>

## 1 About this document

### 1.1 Contents and purpose

This document describes the mounting of the SVP-S 53, SVP-S 54, SVP-S 55, SVP-S 56 control units and the SVP-S 4/5 conversion kit.

### 1.2 Target group

This documentation is aimed exclusively at qualified professionals.

### 1.3 Documents storage

This document must be handed over to the facility operator after mounting and commissioning.

### 1.4 Symbols used

1.

2.

Sequence of action steps



Reference to a chapter



Components may be damaged by electrostatic discharge. Ground your own body before touching a component!

## 2 Safety

### 2.1 Intended use

The SVP-S 5x is a control unit with freely programmable inputs and outputs for dormakaba locks:

- M-SVP 2200 DCW
- SVP 2xxx (F)
- SVA 2xxx (F) and SVI 2xxx (F)
- SVP 4xxx, SVA 4xxx
- SVP 6xxx, SVA 6xxx

### 2.2 Personnel qualification

The actions described in this document must be performed by professionals.

Qualified personnel have the appropriate technical training and experience with the equipment being used. Qualified personnel are responsible for ensuring compliance with the conditions specified by the manufacturer, as well as with applicable regulations and standards.

## 3 Product description

The SVP-S 5x control unit enables the control and analysis of dormakaba M-SVP, SVP and SVA/SVI locks. The range of functions depends on the connected lock.

#### SVP-S 5x control unit variants

- SVP-S 56: SVP-S 5x control board on top-hat rail adapter (125 x 95 mm / 7 SU)
- SVP-S 53: SVP-S 56 installed in plastic housing (202 x 152 mm / 9 PU)
- SVP-S 54: SVP-S 56 with NT-24 XS 2.5 power supply unit installed in plastic housing (254 x 180 mm / 12 PU)
- SVP-S 55: SVP-S 56 with USV-24 power supply unit installed in metal housing (305 x 130 mm)

#### Optional additions

- dormakaba LON network adapter
- dormakaba LAN network adapter
- dormakaba I/O modules
- SVP-S 4/5 conversion kit: For installing the SVP-S 56 control unit in an existing SVP-S 43 or SVP-S 44 control unit

### 3.1 Technical data

#### S5 control board

Supply voltage:	24 V DC +/- 15%
Power consumption:	30 mA
Quiescent current with lock:	approx. 80 mA
Active motor lock:	max. 1.5 A (<1.5 sec.)
Inputs In 1 to In 4 (optocoupler inputs)	Current consumption of inputs per input: at 5 V AC/DC: 3 mA at 12 V AC/DC: 8 mA at 24 V AC/DC: 17 mA at 28 V AC/DC: 28 mA
Outputs Out 1 to Out 6	Power consumption increases by approx. 10 mA for each active relay
Contact load capacity (ohmic load)	24 V, 1 A
Protection class:	dependent on housing
Ambient temperature:	-10°C to +55°C
Rel. humidity	up to 85% (non-condensing)

## 4 Mounting

### 4.1 Mounting preparation

Prepare the extra-low voltage cables and the mains voltage cable separately in accordance with structural requirements.

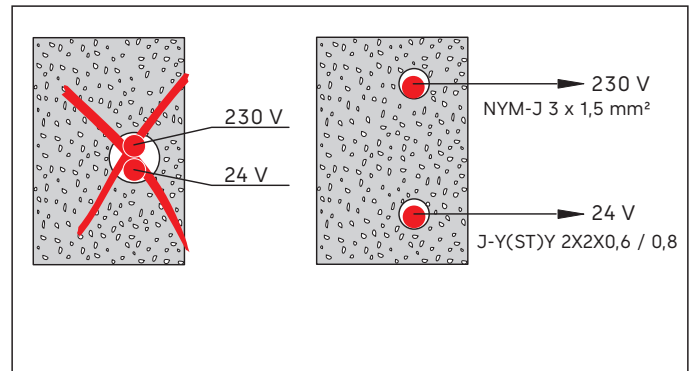

### 4.2 SVP-S 53 mounting

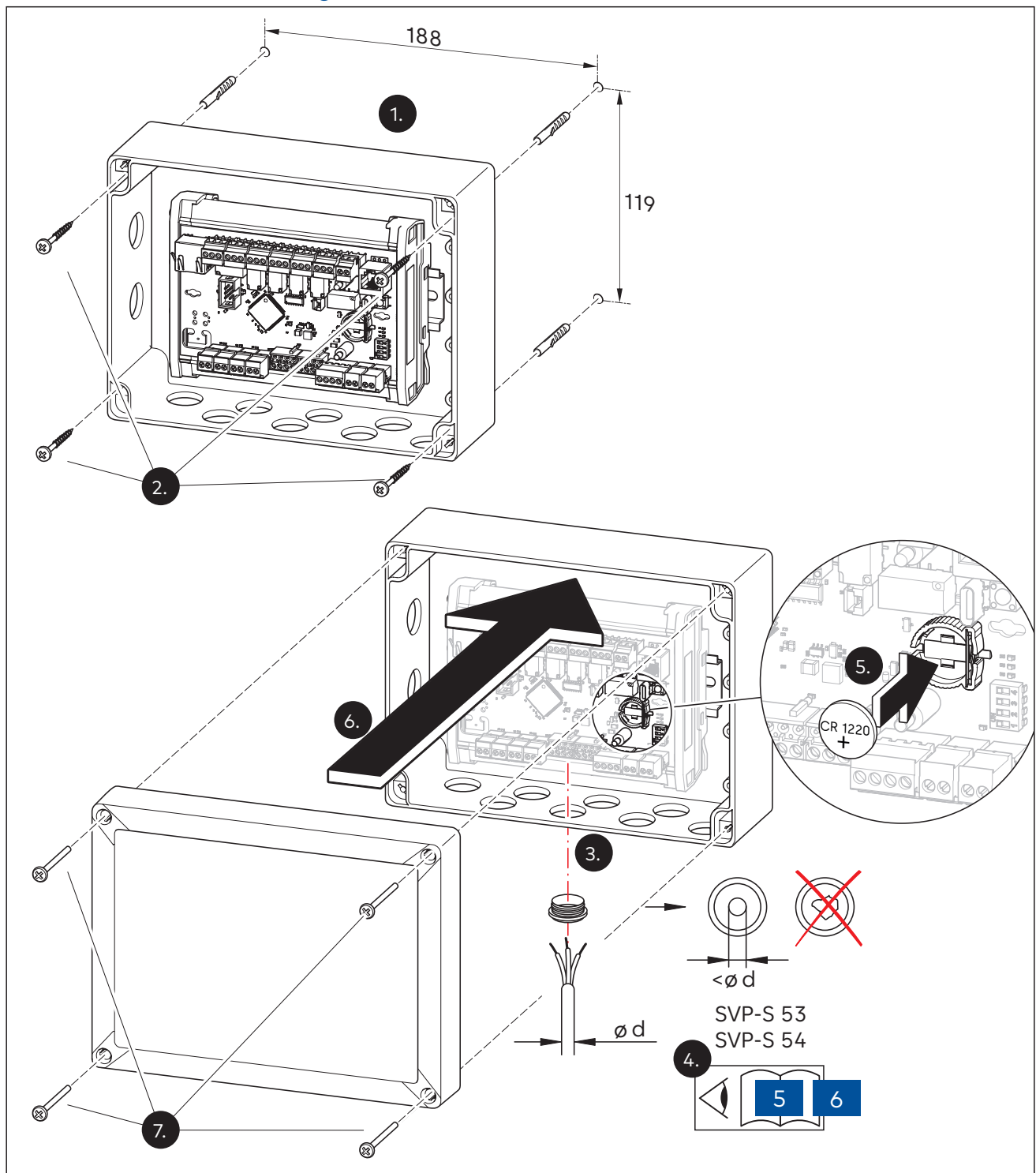

### 4.3 SVP-S 54 mounting

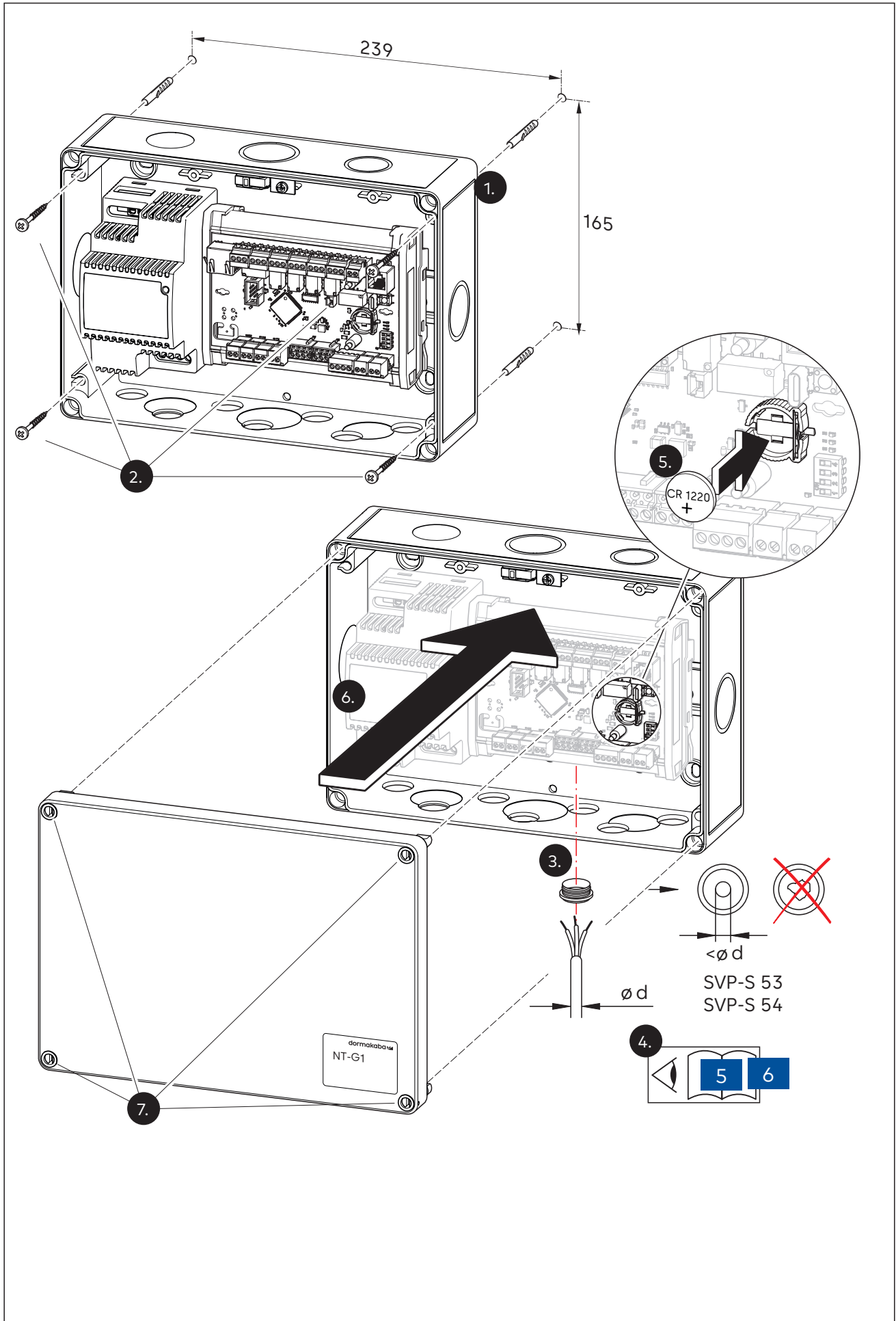

### 4.4 SVP-S 55 mounting

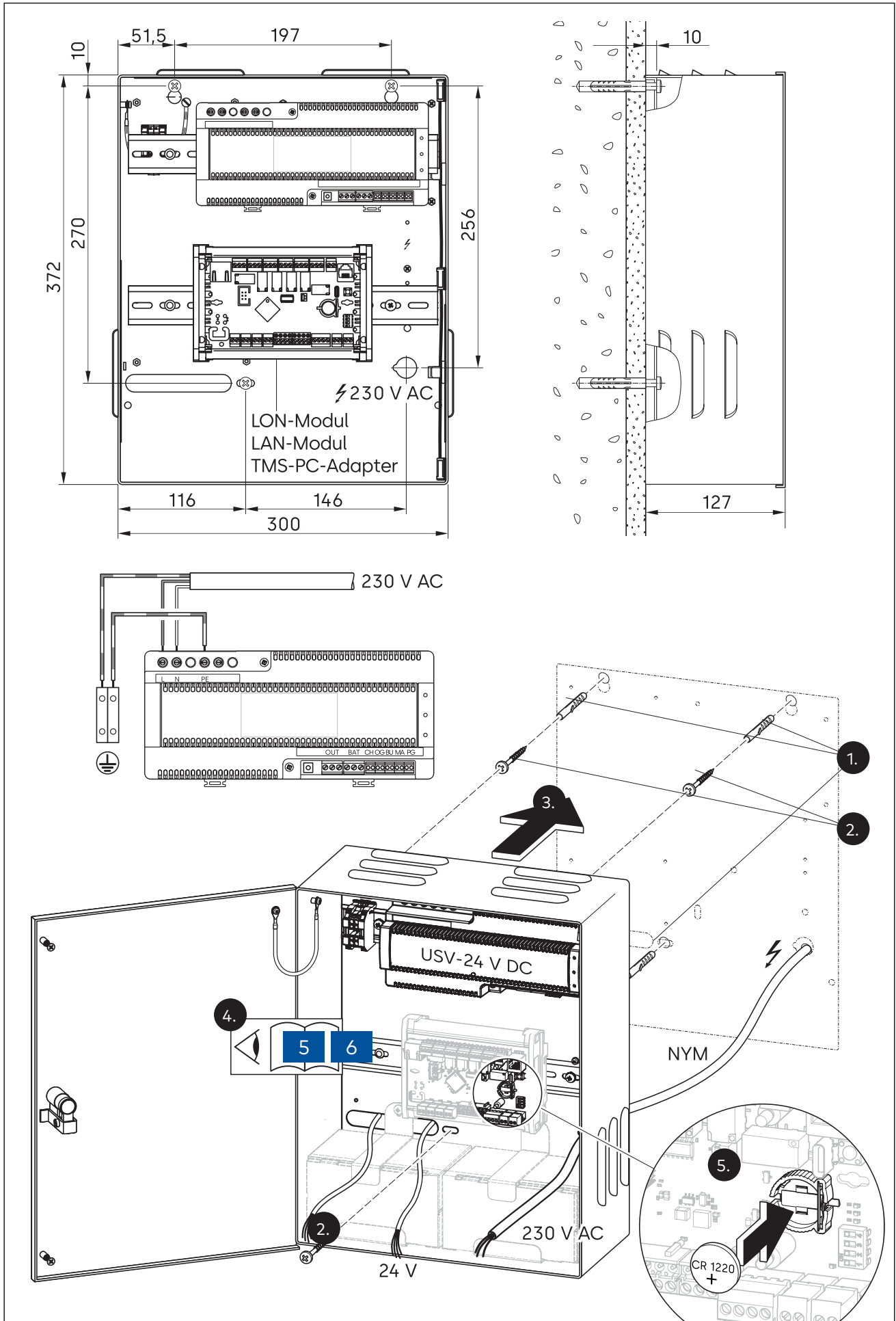

### 4.5 SVP-S 56 mounting with SVP-S 4/5 conversion kit

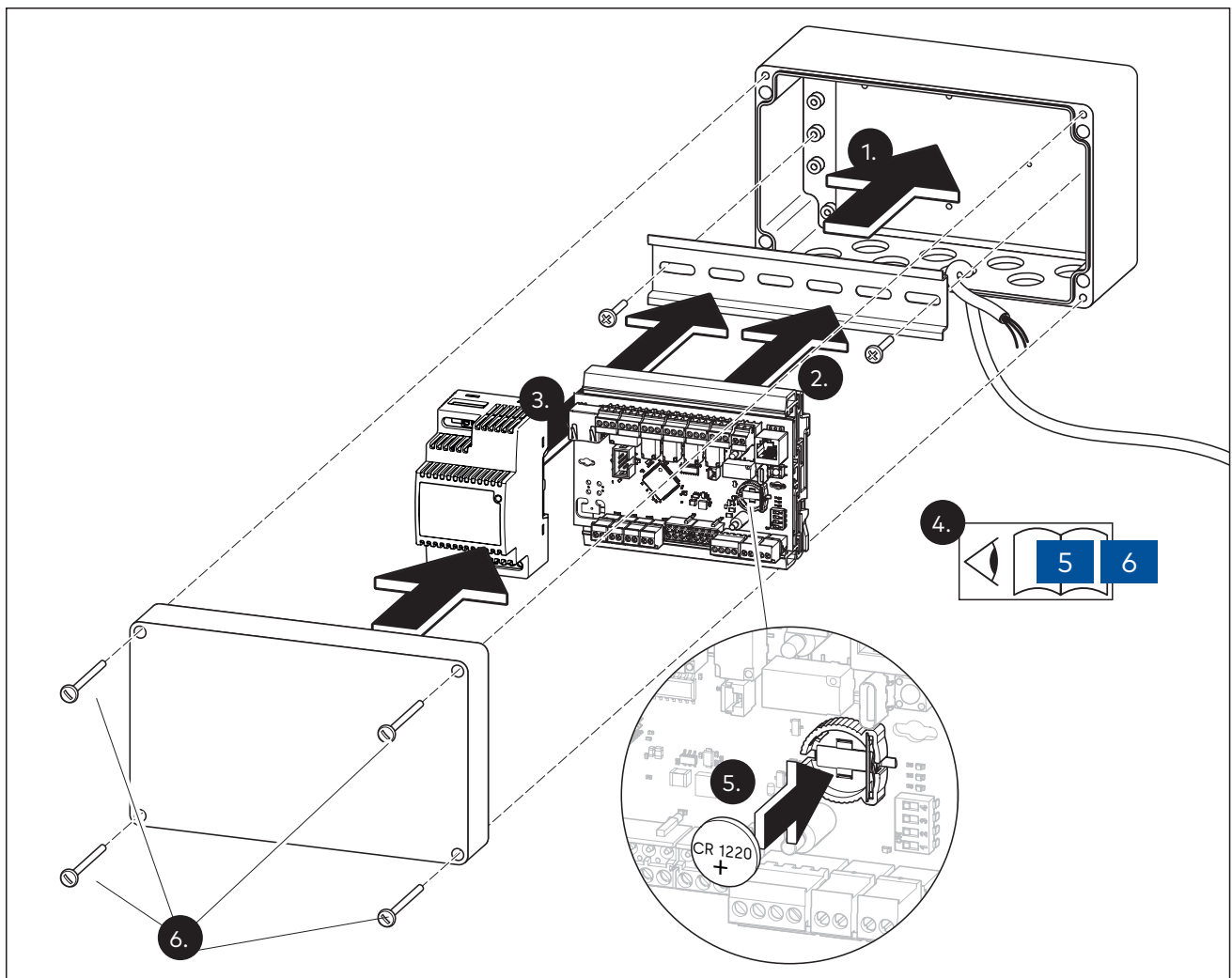
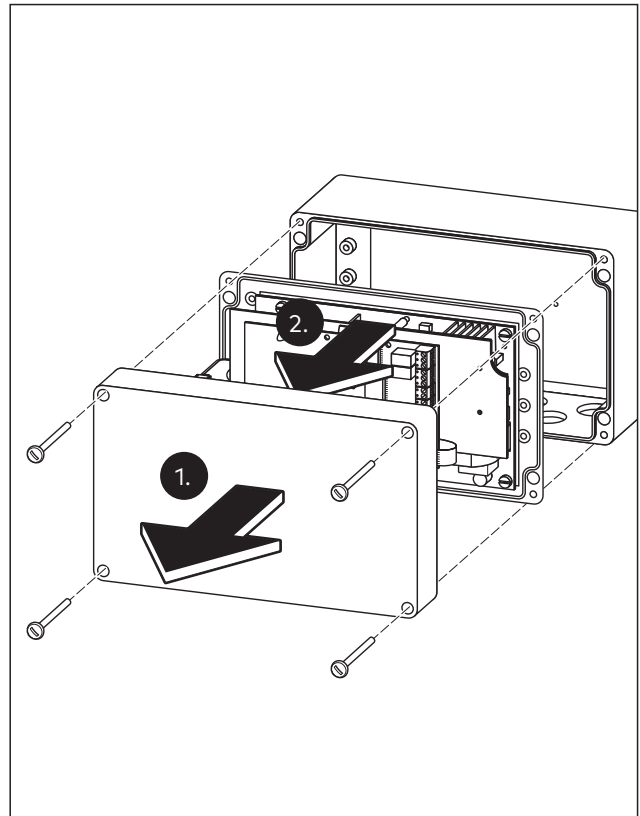
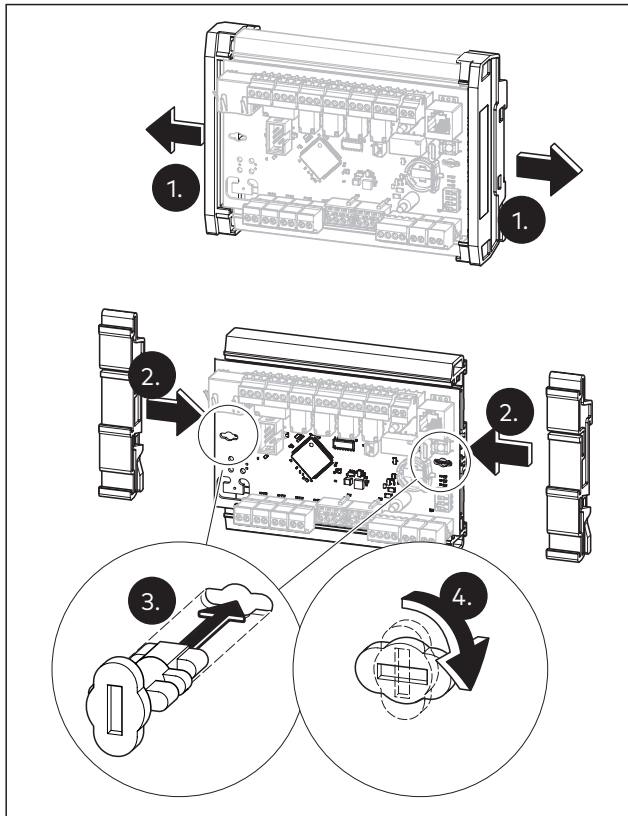

## 4.6 Optional parts

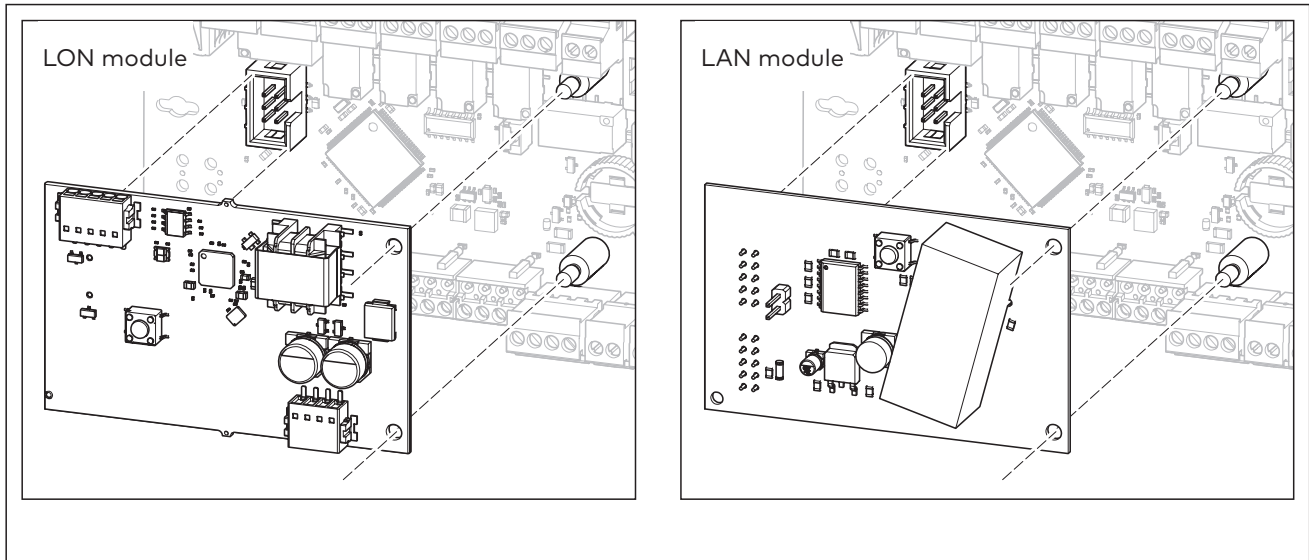

## 5 Connection

### 5.1 Layout of terminals and switches

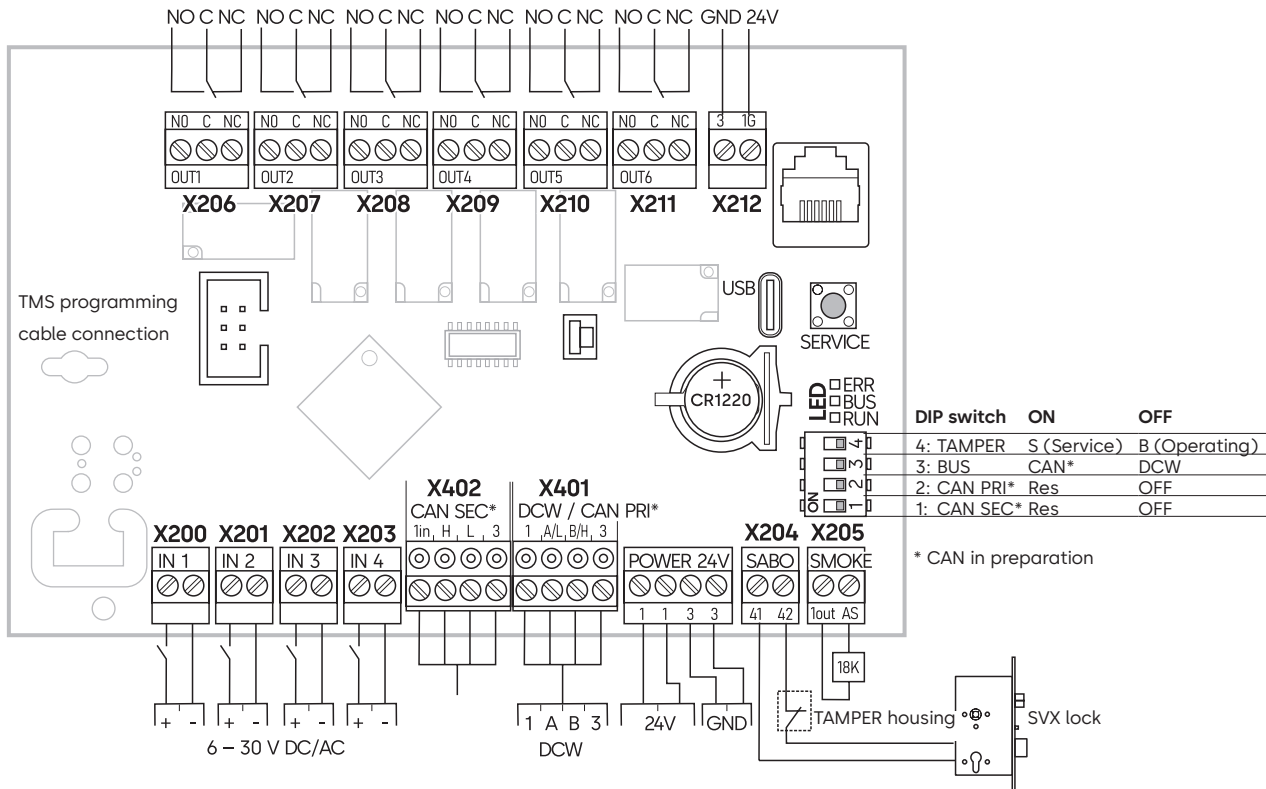

#### 5.1.1 Power supply

Power is supplied via the Power 24V terminal. The power supply is 24V +/-15%. The power required depends on the connected components.

#### 5.1.2 CR1220 battery

The battery ensures that the integrated history works in the event of a power failure.

#### 5.1.3 LED display

The LEDs light up or flash depending on the status.

##### ERR LED (RED)

The LED signals an error in the control unit. See Chapter 8: Error codes.

##### RUN LED (GREEN)

The LED signals the existing bus connection.

- OFF = No DCW® or CAN bus participant configured
- Continuous light = Bus connection okay
- Flashing = Missing bus connection to at least one participant

##### BUS LED (YELLOW)

The LED indicates normal control unit operation.

- OFF = There is no voltage on the circuit board.
- Continuous light = Error-free operation
- Flashing = Initialization, DCW® /CAN bus participants are configured

#### 5.1.4 Service button

The Service button has several functions. Normal mode (BUS LED lights up green continuously):

- Operation up to 3 seconds: No function
- Operation for 3 to 8 seconds: CAN/DCW® network reset
  - **LED flashes until all participants have registered again**
- Operation for 8 to 20 seconds: Reset to factory settings
  - **A restart takes place, all LEDs flash briefly once.**

#### 5.1.5 DIP switch

##### 1 Activation of secondary CAN bus terminal 402

Function in preparation

ON = Terminating resistor active

OFF = Terminating resistance deactivated

##### 2 Activation of primary CAN bus terminal 401

Function in preparation

ON = Terminating resistor active

OFF = Terminating resistance deactivated

##### 3 BUS mode control board: DCW® or CAN

ON = CAN mode, function in preparation

OFF = DCW mode, terminal 401 is active

##### 4 TAMPER switch for suppression of tamper alarm

ON = Service (tamper alarm turned off)

OFF = Operation (tamper alarm activated)

## 5.2 SVP-S 5x with SVP/SVA 2xxx (F)

### Default terminal assignments

(Changes can be made via TMS-Soft)

#### Inputs

Two preset functions are possible

X200 / IN 1-1	Temporary unlocking (access control)
/ IN 1-2	No function
X201 / IN 2-1	Static control (access control)
/ IN 2-2	No function
X202 / IN 3-1	No function
/ IN 3-2	Alarm acknowledgement
X203 / IN 4-1	Door contact connection
/ IN 4-2	No function

### SVP/SVA status messages

X206 / OUT1	SVP/SVA locked active
X207 / OUT2	SVP/SVA unlocked active
X208 / OUT3	SVP/SVA door handle is operated
X209 / OUT4	SVP/SVA cylinder contact active
X210 / OUT5	Door is open (external door contact)
X211 / OUT6	Common alarm
X212 / 1G	PR module function test

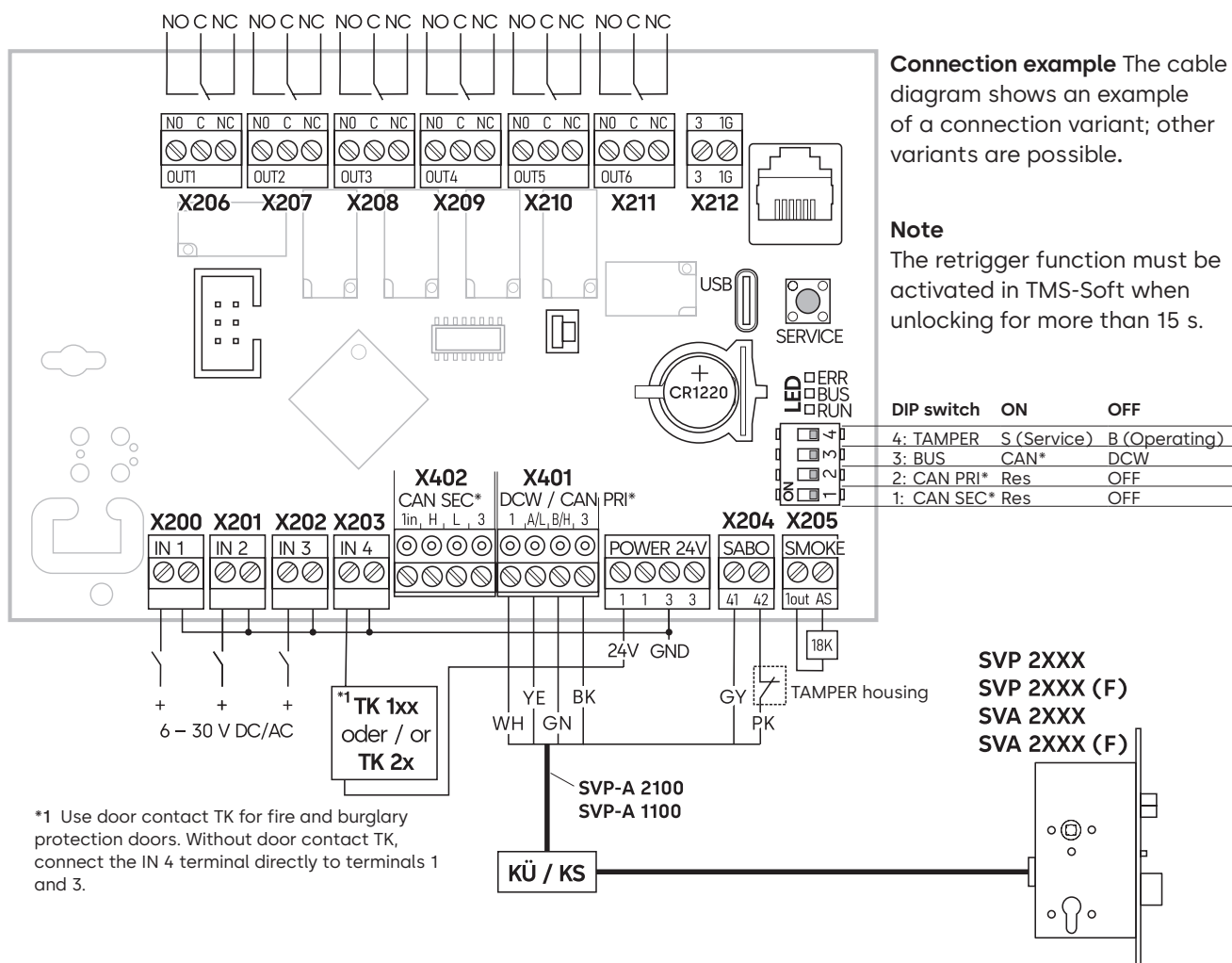

\*1 Use door contact TK for fire and burglary protection doors. Without door contact TK, connect the IN 4 terminal directly to terminals 1 and 3.

## 5.3 SVP-S 5x with SVP/SVA 2xxx and external PR module

### Default terminal assignments

(Changes can be made via TMS-Soft)

#### Inputs

Two preset functions are possible

X200 / IN 1-1	Temporary unlocking (access control)
/ IN 1-2	No function
X201 / IN 2-1	Static control (access control)
/ IN 2-2	No function
X202 / IN 3-1	No function
/ IN 3-2	Alarm acknowledgement
X203 / IN 4-1	Door contact connection
/ IN 4-2	No function

### SVP/SVA status messages

X206 / OUT1	SVP/SVA locked active
X207 / OUT2	SVP/SVA unlocked active
X208 / OUT3	SVP/SVA door handle is operated
X209 / OUT4	SVP/SVA cylinder contact active
X210 / OUT5	Door is open (external door contact)
X211 / OUT6	Common alarm
X212 / 1G	PR module function test (must be activated in TMS-Soft)

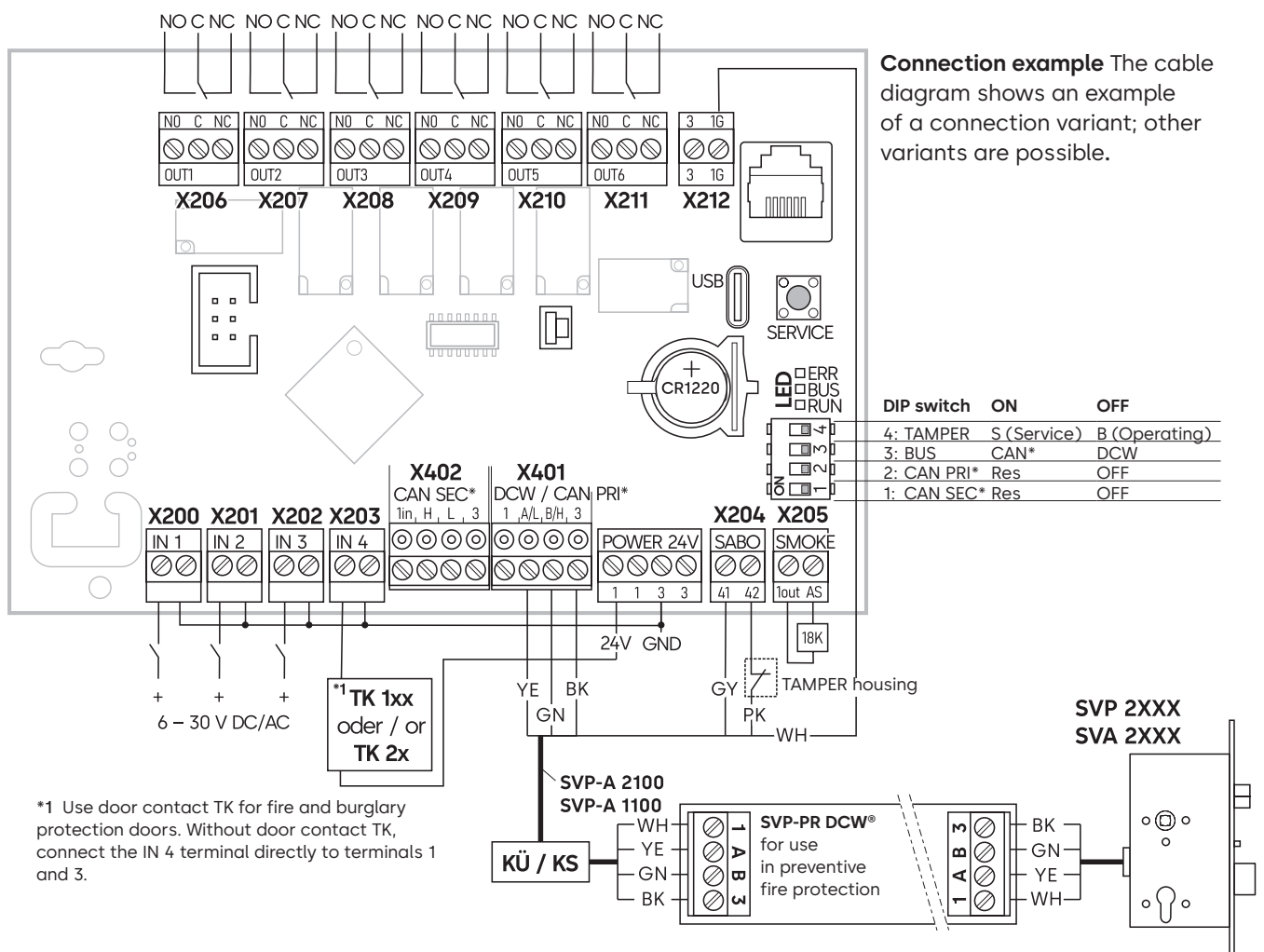

## 5.4 SVP-S 5x with. SVP/SVA 4xxx

### Default terminal assignments

(Changes can be made via TMS Soft)

#### Inputs

Two preset functions are possible

X200 / IN 1-1	SVP/SVA locked
/ IN 1-2	No function
X201 / IN 2-1	SVP/SVA door handle operated
/ IN 2-2	No function
X202 / IN 3-1	Static control (access control)
/ IN 3-2	Alarm acknowledgement
X203 / IN 4-1	Door contact connection
/ IN 4-2	No function

### SVP/SVA status messages

X206 / OUT1	SVP/SVA locked active
X207 / OUT2	SVP/SVA unlocked active
X208 / OUT3	SVP/SVA door handle is operated
X209 / OUT4	SVP/SVA static control
X210 / OUT5	Door is open (external door contact)
X211 / OUT6	Common alarm
X212 / 1G	No function

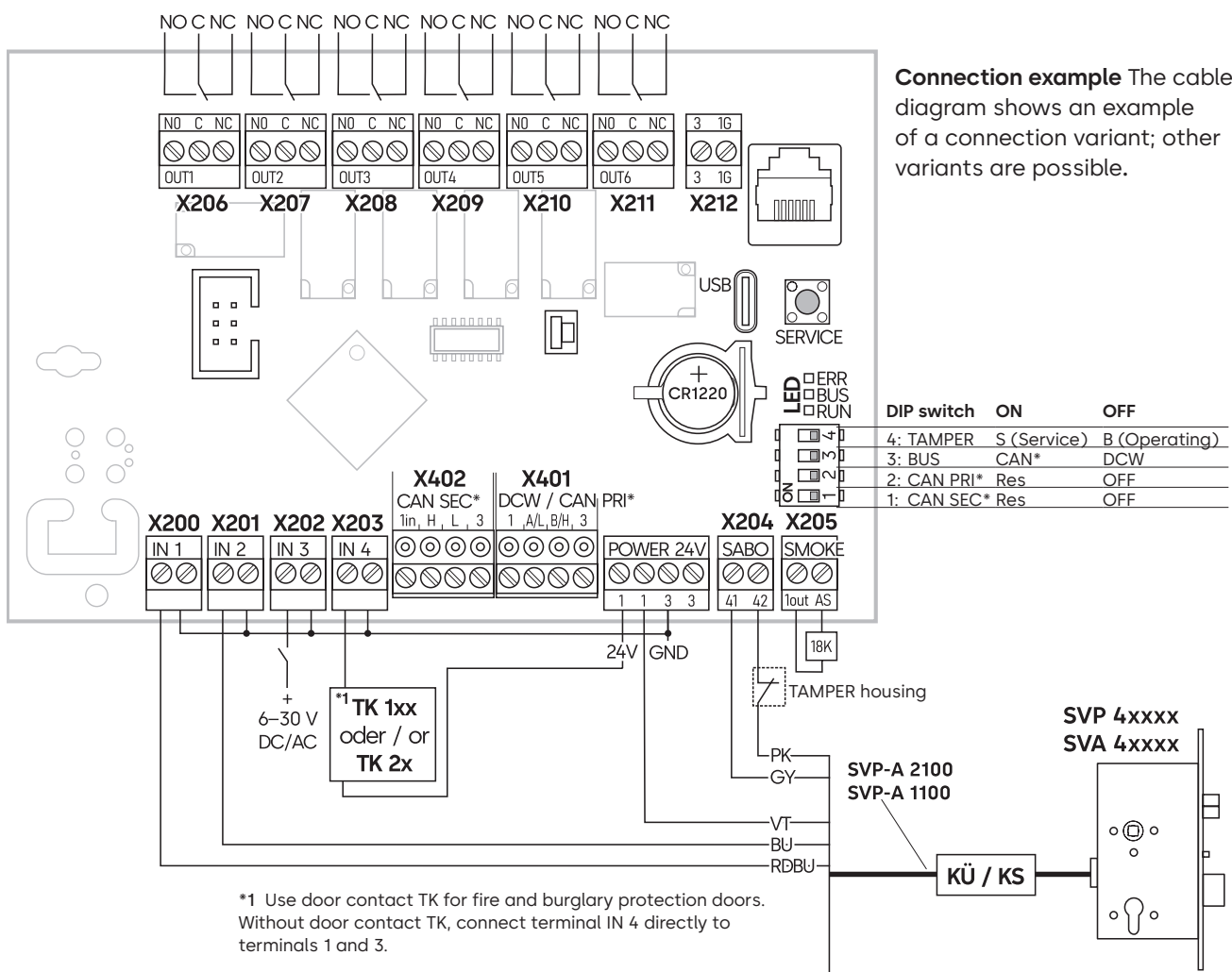

YE (C) and BN (NC)	= Trigger latch on
YE (C) and GYPK (NO)	= SVP unlocked
YE (C) and GN (NO)	= Cylinder contact
VT (C) and RDBU (NC)	= SVP locked.
VT (C) and BU ( NO)	= Door handle operated
GY and PK	= Anti-tamper circuit

## 5.5 SVP-S 5x with SVP/SVA 6xxx

### Default terminal assignments

(Changes can be made via TMS-Soft)

#### Inputs

Two preset functions are possible

X200 / IN 1-1	SVP/SVA locked
/ IN 1-2	No function
X201 / IN 2-1	SVP/SVA door handle operated
/ IN 2-2	No function
X202 / IN 3-1	Static control (access control)
/ IN 3-2	Alarm acknowledgement
X203 / IN 4-1	Door contact connection
/ IN 4-2	No function

### SVP/SVA status messages

X206 / OUT1	SVP/SVA locked active
X207 / OUT2	SVP/SVA unlocked active
X208 / OUT3	SVP/SVA door handle is operated
X209 / OUT4	SVP/SVA static control
X210 / OUT5	Door is open (external door contact)
X211 / OUT6	Common alarm
X212 / 1G	No function

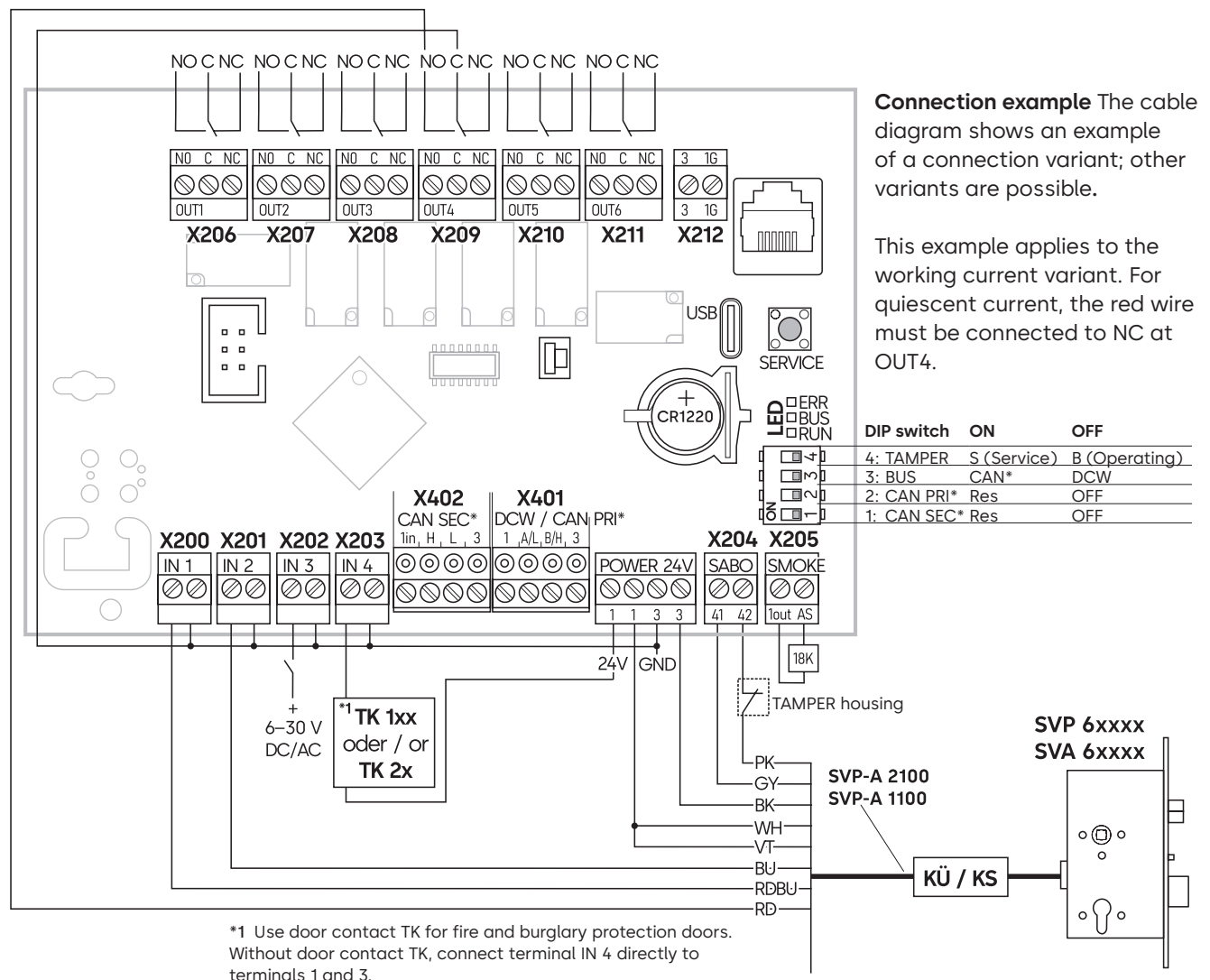

YE (C) and BN (NC)	= Trigger latch on
YE (C) and GYPK (NO)	= SVP unlocked
YE (C) and GN (NO)	= Cylinder contact
GY and PK	= Anti-tamper circuit
VT	= "SVP/SVZ/SVA locked" and "Door handle operated", C
BU	= "Door handle operated", NO
RDBU	= "SVP/SVZ/SVA locked", NC
RD	= "Engage door handle" via GND contact, operating current = NO, quiescent current = NC

## 5.6 SVP-S 5x with M-SVP 2xxx / 22xx

### Default terminal assignments

(Changes can be made via TMS-Soft)

#### Inputs

Two preset functions are possible

X200 / IN 1-1	Temporary unlocking (access control)
/ IN 1-2	No function
X201 / IN 2-1	Static control (access control)
/ IN 2-2	No function
X202 / IN 3-1	Activate day-latch function
/ IN 4-2	Alarm acknowledgement
X203 / IN 4-1	Door contact connection
/ IN 4-2	No function

#### M-SVP status messages

X206 / OUT1	M-SVP locked active
X207 / OUT2	M-SVP unlocked active
X208 / OUT3	M-SVP door handle is operated
X209 / OUT4	M-SVP cylinder contact active
X210 / OUT5	Door is open (external door contact)
X211 / OUT6	Common alarm
X212 / 1G	PR module function test (must be activated in TMS-Soft)

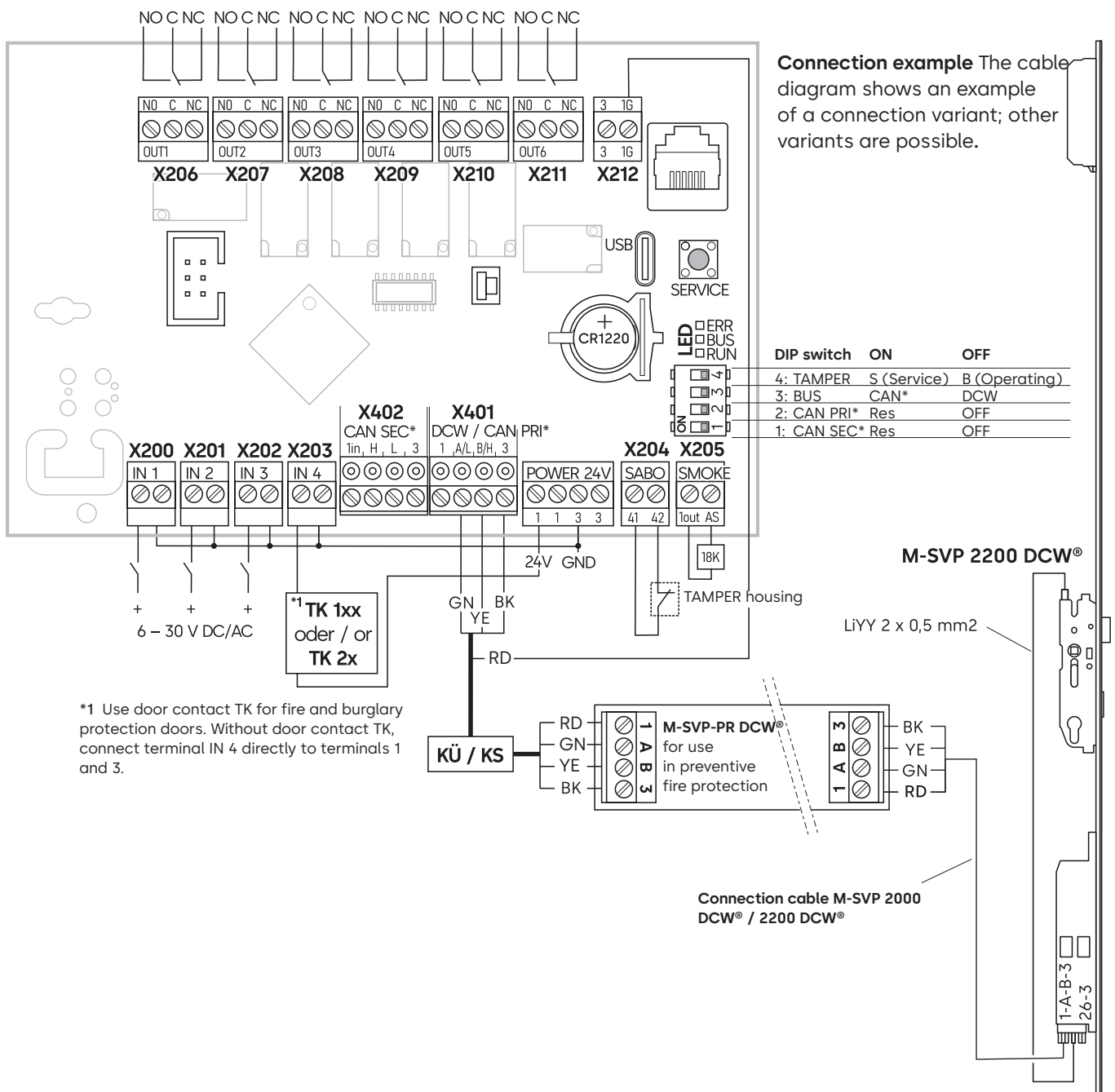

## 5.7 SVP-S 5x with SVA 2xxx (F) and SVI 2xxx

### Default terminal assignments SVP-S 5x

(Changes can be made via TMS-Soft)

#### Inputs

Two preset functions are possible

X200 / IN 1-1	Activate SVA/SVI temporary unlocking
/ IN 1-2	No function
X201 / IN 2-1	Static control SVA
/ IN 1-2	No function
X202 / IN 3-1	Static control SVA/SVI
/ IN 3-2	Alarm acknowledgement
X203 / IN 4-1	Door contact connection
/ IN 4-2	No function

#### SVP/SVA status messages

X206 / OUT1	SVA locked active
X207 / OUT2	SVA/SVI unlocked active
X208 / OUT3	SVA door handle is operated
X209 / OUT4	SVA cylinder contact active
X210 / OUT5	SVA unlocked active
X211 / OUT6	Triggers a common alarm event
X212 / 1G	PR module function test (must be activated in TMS-Soft)

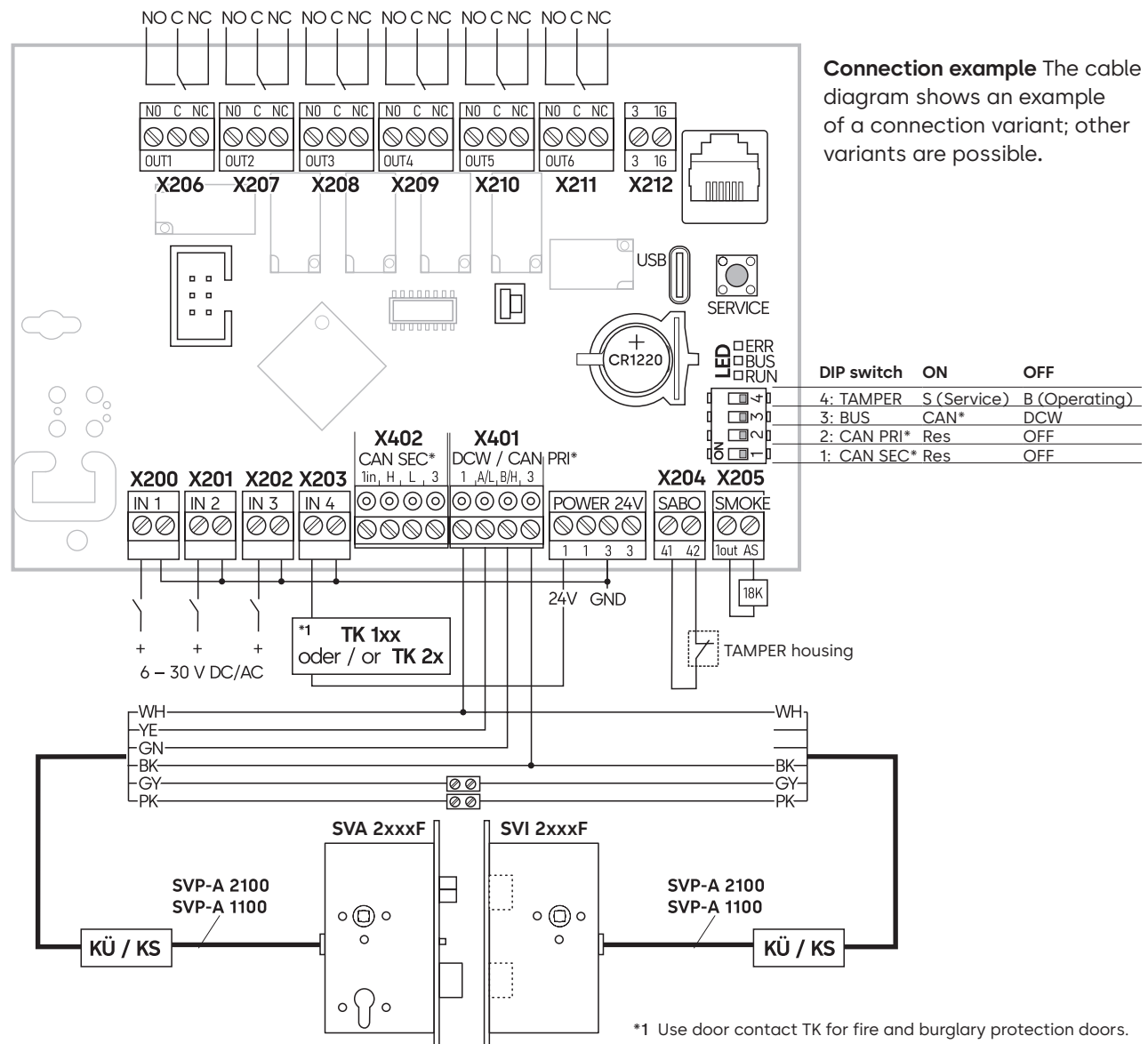

\*1 Use door contact TK for fire and burglary protection doors. Without door contact TK, connect terminal IN 4 directly to terminals 1 and 3.

## 5.8 SVP-S 5x with SVA/SVI (ED100 / ED250 control)

### ED100/250 active door leaf

Ud = 0 = Unlocking time

du = 0 = Day activation

Ad = 5 = Castor angle  
(recommended)

### ED100/250 passive door leaf

Ud = 0 = Unlocking time

**Default terminal assignments SVP-S 5x**  
(Changes can be made via TMS-Soft)

#### Inputs

Two preset functions are possible

X200	/ IN 1-1	Activate SVA/SVI temporary unlocking
	/ IN 1-2	No function
X201	/ IN 2-1	Static control SVA
	/ IN 2-2	No function
X202	/ IN 3-1	Static control SVA/SVI
	/ IN 3-2	Alarm acknowledgement
X203	/ IN 4-1	Door contact connection
	/ IN 4-2	No function

#### SVP/SVA status messages

X206 / OUT1	SVA locked active
X207 / OUT2	SVA/SVI unlocked active
X208 / OUT3	SVA door handle is operated
X209 / OUT4	SVA cylinder contact active
X210 / OUT5	SVA unlocked active
X211 / OUT6	Triggers a common alarm event
X212 / 1G	PR module function test (must be activated in TMS-Soft)

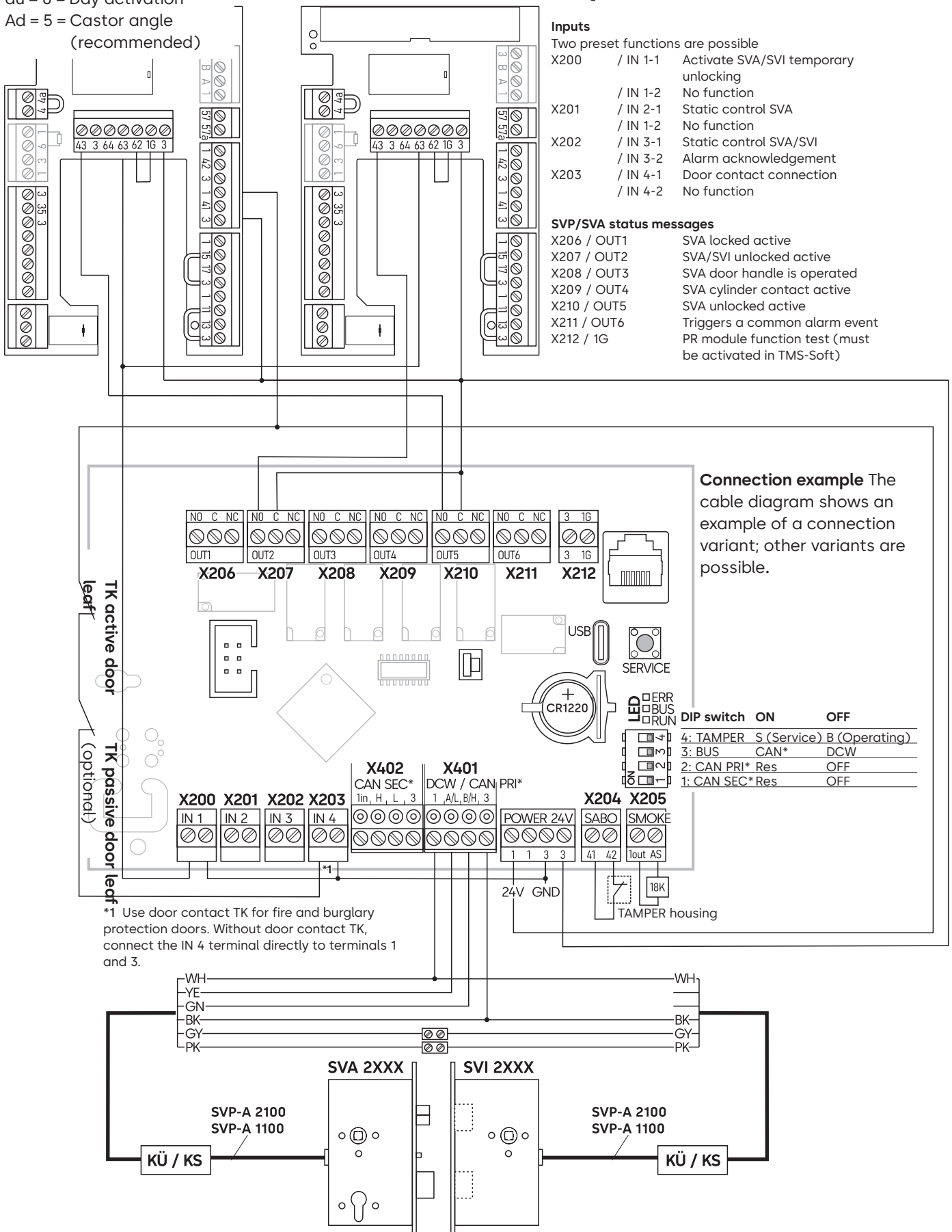

## 5.9 DCW® key switch default functions

Different functions are preset on the right and left keys depending on the address set on the DCW® key switch (changes can be made via TMS-Soft).

### 5.9.1 Address 1

#### Right keystroke functions

- 1: Temporary/long-term/permanent unlocking
- 2: Activate alarm acknowledgement
- 3: No function

#### Left keystroke functions

- 1: Activate locking
- 2: Delete maintenance alarm

### 5.9.2 Address 2

#### Right keystroke functions

- 1: Temporary unlocking
- 2: Activate alarm acknowledgement
- 3: No function

#### Left keystroke functions

- 1: Activate locking
- 2: Delete maintenance alarm

### 5.9.3 Address 3

#### Right keystroke functions

- 1: Long-term unlocking
- 2: Activate alarm acknowledgement
- 3: No function

#### Left keystroke functions

- 1: Activate locking
- 2: Delete maintenance alarm

### 5.9.4 Address 4

#### Right keystroke functions

- 1: Permanent unlocking
- 2: Activate alarm acknowledgement
- 3: No function

#### Left keystroke functions

- 1: Activate locking
- 2 (Left key keying area pressed >15 s): Delete maintenance alarm

#### Overview of external I/O modules' inputs and outputs

I/O	Address 1	Address 2	Address 3	Address 4
IN1	Permanent unlocking	Trigger GMA/BMA smoke detectors	No function	SVP/SVA door handle operated
IN2	Long-term unlocking M1	Tamper contact	Interlock inhibiting input	SVP/SVA locked
IN3	Activate locking	Door contact	An interlock door is unlocked	SVP/SVA unlocked
IN4	No function	No function	Temporary unlocking M1	Radar detector (E)
OUT1	SVP/SVA unlocked	Permanent unlocking active	Pre-alarm (door open alarm)	No function
OUT2	SVI unlocked	Powerfail active	Main alarm (door open alarm)	SVP/SVA cylinder contact
OUT3	SVI locked	No function	No function	ED impulse control
OUT4	Smoke alarm	No function	No function	ED radar control

## 5.9.5 External I/O modules

Up to 4 external I/O modules can be connected to terminal X401 parallel to the lock.

The inputs/outputs of the S5x board do not change. Different assignments are preset depending on the address set on the external I/O module (changes possible via TMS-Soft).

See table on this page for more details.

## 6 Commissioning

Requirement: All unit components are connected in accordance with the technical documents.

1. Set the control board's operating mode DIP Switch 4 = ON S (Service).
  2. Connect the power supply.
    - ▶ The green, yellow and red LEDs light up briefly. Depending on the configuration, additional LEDs light up.
  - **If the green LED lights up continuously, the configuration is completed successfully.**
3. Check the lock functions.
4. Set DIP switch 4 to OFF B (Operating) to activate the tamper alarm.

## 7 Firmware update

Requirement: The control board is connected to TMS-Soft®. The firmware is loaded via the selected door. The exact procedure is described in the TMS-Soft® documentation.

The transfer may take several minutes.

1. After successful transfer, quickly press the Service button 3x.
  - ▶ The firmware update is in progress. This is followed by an automatic restart.
- **The firmware version update can be checked in TMS-Soft®. See TMS-Soft® documentation.**

## 8 Error codes

If there is a fault, the ERR LED (red LED) signals the error. This is indicated by the number of error numbers flashing. Example: Flashing once equals error code 1, flashing twice equals error code 2, and so on. An error flashing sequence ends with the red LED lighting up continuously for three seconds. The error flashing sequence then starts again.

Error code / name	Solution
Description / cause	
<b>1 / Bus Off CAN</b> (only occurs in CAN mode!) -> CAN communication is no longer possible <ul style="list-style-type: none"> <li>• CAN controller in Bus OFF state</li> </ul>	Check wiring -> Power-on required
<b>2 / LSS address assignment failed</b> (only occurs in CAN mode!) -> No communication possible <ul style="list-style-type: none"> <li>• CAN address assignment failed</li> <li>• Unauthorized device types, or maximum number of allowed devices exceeded</li> </ul>	Check connected participants and wiring -> Carry out a CAN reset
<b>3 / SVI communication</b> -> Unable to communicate with SVI Note: Is only detected in CAN mode (in DCW mode, SVI is displayed as a missing DCW participant).	Check SVI and wiring -> Automatic confirmation if status is cancelled. -> If status is permanent, replace the lock
<b>4 / EEPROM initialization</b> -> The lock is no longer unlocked <ul style="list-style-type: none"> <li>• EEPROM initialization failed</li> </ul>	Reset to factory settings via service button. -> Automatic confirmation if status is cancelled. -> If status is permanent, replace SVP-S 5x
<b>5 / Drive error, drive blockage detected</b> -> The lock can no longer be unlocked by a drive	Unlock the lock mechanically using the door handle and check for a possible blockage -> If status is permanent, replace the lock
<b>6 / Supply voltage</b> -> The lock is no longer unlocked <ul style="list-style-type: none"> <li>• Nominal voltage 24V DC +/- 15% outside the tolerance</li> </ul>	Check supply voltage -> Automatic confirmation if status is cancelled.
<b>7 / Smoke alarm</b> -> Smoke alarm is on	-> Automatic confirmation if status is cancelled.
<b>8 / Break-in, tamper</b> -> Tamper message, if necessary via relay outputs <ul style="list-style-type: none"> <li>• Break-in / tamper attempt detected</li> </ul>	Check the unit -> Acknowledgement via key switch or cylinder contact
Error code / name	Solution
Description / cause	

---

**9 / Fault, general malfunction**

- > Signaling via ERR LED
- Supply voltage over-/undervoltage
- Latch blockage (latch does not fully extend)
- Lock does not lock
- Invalid contact sequence
- Deadbolt does not move into start position

Check the lock, replace if necessary  
 Measure supply voltage  
 -> Automatic acknowledgement if status is cancelled

---

**10 / PR module error**

- > The lock is no longer unlocked
- Failed PR module test (when using locks with PR modules)

Check PR module  
 -> Perform restart, test is performed automatically after 2 minutes  
 -> If status is permanent, replace the lock

---

**11 / Maintenance alarm**

- > LED signaling
- Sequence of opening cycles until maintenance

Perform maintenance  
 -> Confirmation via input with correspondingly parameterized function

---

**12 / Internal voltage error**

- > The lock is no longer unlocked
- Internal voltage is outside the permissible limit range

Check voltage  
 -> Automatic acknowledgement if status is cancelled  
 -> If status is permanent, replace SVP-S 5x

---

**13 / Service button faulty**

- > LED signaling
- Service button is pressed  $\geq 20$ s

-> Automatic acknowledgement if status is cancelled  
 -> If status is permanent, replace SVP-S 5x

---

**14 / Device ID not as configured**

- > LED signaling
- After a PowerOn, a new, different lock/device than originally configured is detected.

-> Automatic acknowledgement if status is cancelled  
 -> If status is permanent, replace the lock

---

## 9 Disassembly and disposal

Disassembly is carried out in the reverse order of mounting and must be carried out by qualified personnel.



The product must be disposed of in an environmentally friendly manner. Electrotechnical parts and batteries must not be disposed of as domestic waste. Dispose of electrotechnical parts and batteries in the designated acceptance and collection points. Refer to the statutory regulations for your country.

060865-45532/18825 – 06/2026  
Copyright © dormakaba 2026



[www.dormakaba.com](http://www.dormakaba.com)

dormakaba Deutschland GmbH  
DORMA Platz 1  
58256 Ennepetal  
Germany  
Central Office: +49 2333 793-0  
Service DE: 0800 524 0246

[www.dormakaba.com](http://www.dormakaba.com)