

Saffire™ EVO LZ-L

Cloud-Connected Smart Cylindrical Lock



Applications

- Add smart locks for new construction projects or retrofits
- Get real-time notifications, including events and access anomalies
- Manage access rights to allow or revoke access for residents and visitors in real-time, from anywhere
- Easily send digital keys or PIN codes to residents and visitors from a mobile device
- Residents can use their mobile device, RFID credentials, or PIN to access their residence or common areas
- Provide convenient one-time or recurring access PINs to service and maintenance personnel
- Control when and where residents and visitors can go throughout the building
- Quickly delete lost access media to keep the building secure.

Overview

Saffire EVO LZ-L is a cloud-connected RFID lock that combines high-performance with aesthetics, seamlessly integrating with building technology providers and amenities for multifamily housing properties. The Saffire EVO LZ-L provides an easy-to-use, secure and flexible solution with the benefits of real-time connectivity. It includes the convenience of using either mobile devices, RFID credentials or secure PINs for access to resident units, common areas and perimeter doors.

Security with IoT connectivity

The Saffire EVO LZ-L is equipped with Wi-Fi onboard, ensuring connectivity to the

dormakaba Lyazon cloud and seamless integration to our Lyazon partner platforms for real-time events and user notifications. Online connectivity of the Saffire EVO LZ-L also provides continuous updates for built-in device security.

Designed for our aggregator partners

The Saffire EVO LZ product portfolio is specifically designed to be integrated with our dormakaba Lyazon partner platforms to ensure a premium user experience for multifamily residents. The dormakaba Saffire EVO LZ cloud-connected smart locks allow easy access management of residences, amenities, common areas and perimeters, all through a single integrated platform.

Security features

- Online connectivity ensures continuous firmware updates for increased device security
- BHMA A156.2 Grade 2
- UL 10C 3-hour fire rating
- Non-volatile memory maintains lock programming and audit records
- Staff monitoring with RFID keycard audits
- Tamper-proof design
- No need to visit the lock to update access

Factsheet

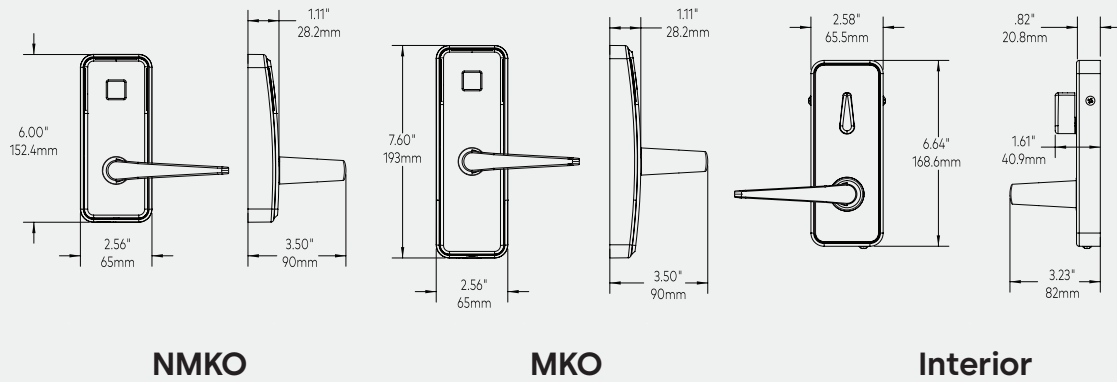

Mechanical Features

Description	Online connectivity ensures continuous updates for increased device security. Supports dormakaba RFID, Bluetooth®, and keypad credentials
Handing	Left or right factory-handed, field-reversible
Levers	Essen, Von and Troy
Finishes**	626 satin chrome, 606 satin brass, 619 satin nickel, 625 bright chrome, 613 oil-rubbed bronze, and 622 black.
Door Thickness	From 1 3/8" to 2 1/8" (35mm to 65mm)
Standard Backset	ASM: 2 3/4" (70mm)
Batteries	3AA. Low-battery indicator to help with preventative maintenance is visible on the device and has an event notification in the system. Passive warning and notification.
Concealed Key Override	Optional MKO: Lori KIK core (keyed-alike, master key)
Electronic Battery Backup	Electronic lock power supply (ELPS) battery back-up. ELPS part number 118-515990
Wi-Fi Online Control	Wi-Fi 802.11 b/g/n WPA2, WPA AES 128 and TLS 1.2 >/-70dB signal strength at the lock

Mobile Access

BLE Enabled	Bluetooth Low Energy 2.4 GHz version 4.2, iOS or Android mobile device support, AES 128 and DTLS security, supported through partner mobile app
--------------------	---

** dormakaba utilizes PDV (physical vapor deposition) finishes in some instances

Lock Operation

Flexible Connectivity	Supports secure creation and updates to credentials with or without complete Wi-Fi coverage
No Touring	New credentials can be securely issued and applied to lock through Wi-Fi or BLE
Electronic Access	User defined: customizable access for residents, visitors and property managers available through partner application
Date/time Stamp	Real time: date and hours/minutes; automatically adjusts for daylight saving time
Audit Trail	Audit trail managed through Wi-Fi. 5,000 events
Passage Mode	Set by authorized key
Lockout Mode	Set by authorized key
Toggle Mode	Use of credential is needed to lock the door after exiting unit. This stops accidental resident lockouts and delivers full audit trail to ownership/management
Credential Formats	dormakaba ComID high-security credentials 13.56MHz MIFARE DESFire EV2/EV3 ISO card or fob/mobile access credentials (BLE) / 6-digit PIN codes
Feedback LED	Light indicators
Diagnostics	Lock diagnostics through partner application
Memory	Non-volatile memory stores up to 5,000 events
Privacy Override	Default emergency key only (user selectable)

Certifications & Testing

Certification	ANSI/BHMA A156.25, ANSI/BHMA A156.2 Grade 2
Accessibility Standard	Complies with 2010 ADA Standards for Accessible Design - Art. 309.4 (Operable Parts). Lock must be installed strictly according to the dormakaba installation instructions and the ADA Standards and Regulations applicable for each facility, to be able to fulfill compliance with ADA requirements.
Fire Rating	Meets UL 10C and ULC S-104, on fire door rated up to and including 3 hours
Electronics	Compliant with RED Directive 2014/53/EU for electromagnetic compatibility and FCC part 15 and RSS-247 Industry Canada requirements
Environmental Operating Conditions	-31°F to 158°F (-35°C to 70°C), 0% to 90% non-condensing humidity at 86°F (30°C) meets IP54

Warranty

Standard Warranty	Two years
--------------------------	-----------

Notes

Credential Formats	Only dormakaba-issued RFID credentials are supported
Flexible Connectivity	Feature is accessible via API and requires partner integration

© dormakaba 2026 Information on this sheet is intended for general use only. dormakaba reserves the right to alter designs and specifications without notice or obligation. All trademarks are the property of their respective owners.

Any questions? We would be happy to advise you.

Contact us at: 1 800 849 8324