

doxycycline

doxycycline

doxycycline

doxycycline

doxycycline

doxycycline

doxycycline

doxycycline

doxycycline

doxycycline

doxycycline

doxycycline

doxycycline

doxycycline

doxycycline

doxycycline

doxycycline

doxycycline

doxycycline

doxycycline

doxycycline

doxycycline

doxycycline

doxycycline

doxycycline

doxycycline

doxycycline

doxycycline

doxycycline

doxycycline

doxycycline

doxycycline

doxycycline

doxycycline

doxycycline

doxycycline

doxycycline

doxycycline

doxycycline

doxycycline

doxycycline

doxycycline

doxycycline

doxycycline

doxycycline

doxycycline

doxycycline

doxycycline

doxycycline

doxycycline

doxycycline

# Self-locking emergency escape locks

SVP

SVA/SVI

M-SVP

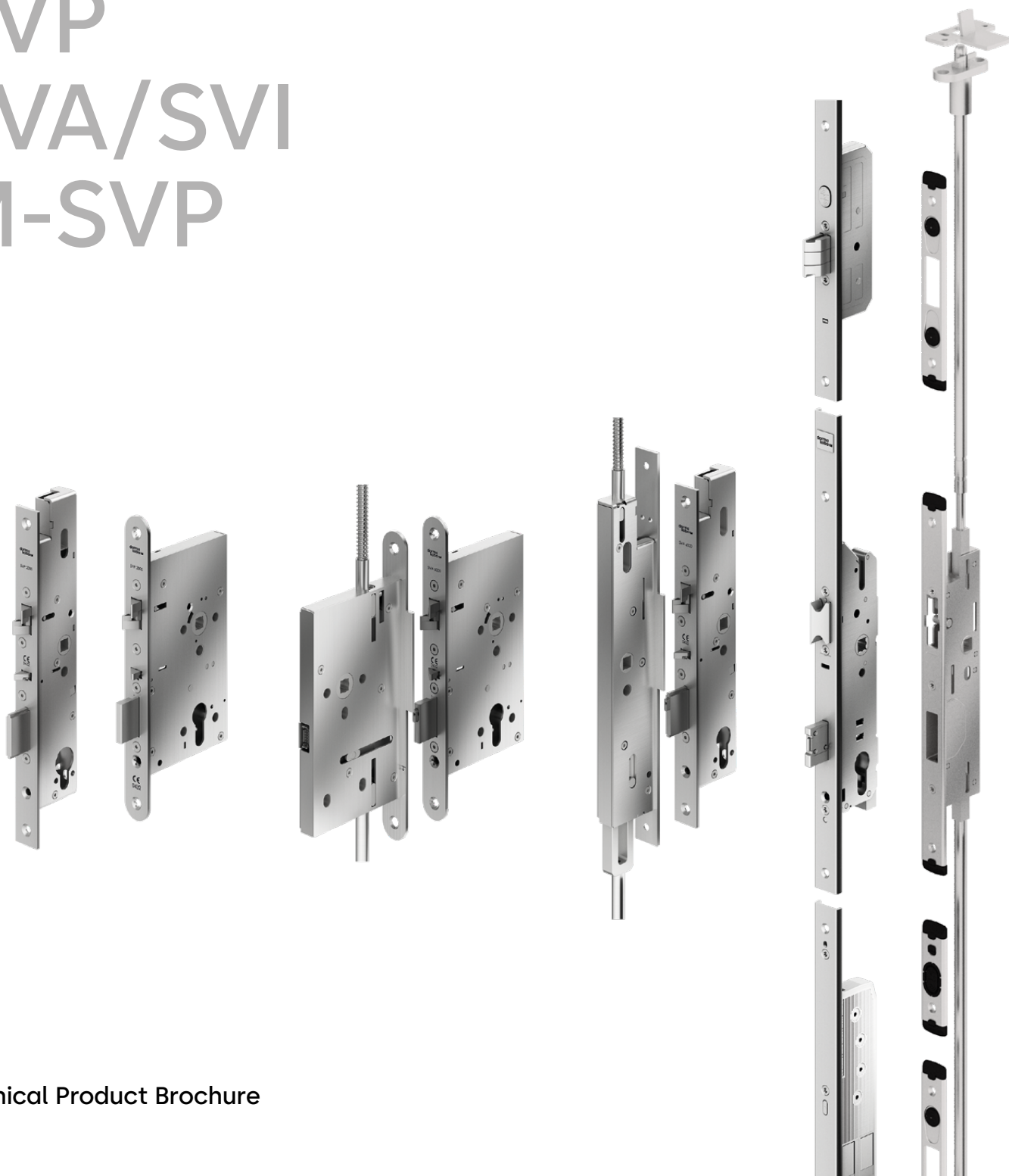

SVP	Emergency-escape lock with automatic locking action for single-leaf doors
SVZ	Access lock with automatic locking action (without emergency escape function)
SVA	Emergency-escape lock with automatic locking action, active, for the active door leaf in double-leaf doors
SVI	Emergency-escape lock with automatic locking action, inactive, for the passive door leaf in double-leaf doors
SVP-S	Control unit for SVP, SVA, SVI and M-SVP
SVP-PR	Power reserve module for SVP, SVA
SVP-SI	Security door fitting for SVP, SVA and M-SVP
M-SVP	Multipoint emergency escape lock with automatic locking action
M-SVP-PR	Power reserve module for M-SVP
CAN	Controller area network, bus system
DCW®	dormakaba connect and work, bus system
ED	Electric revolving door drive
SR	SafeRoute
TS	Door closer
VB	Timber door
RR	Narrow stile door (tubular frame)
PZ	Profile cylinder
RZ	Round cylinder



Current version of brochure Self-locking emergency escape locks SVP, SVA/SVI, M-SVP online

# Contents

<b>Introduction Emergency-escape locks with automatic locking action</b>	<b>05</b>
Features and functions	06
Overview and selection guide SVx	08
<b>SVP/SVZ – Emergency-escape locks with automatic locking action for single-leaf doors</b>	<b>10</b>
Overview	10
Features and functions	11
Dimensions and sections	12
SVP 5000 – Mechanical emergency-escape locks	18
SVP 4000 – Mechanical emergency-escape locks with electrical status monitoring	20
SVP 6000 – Emergency-escape lock with monitoring functions	22
SVZ 6000 – Lock with monitoring functions without emergency escape function	26
SVP 7000 Air – Battery operated emergency-escape lock	28
SVP 2000 – Emergency escape motor lock	30
SVP 2000 F – Emergency escape motor lock with PR module for fire/smoke doors	32
<b>SVA/SVI – Emergency-escape lock combinations with automatic locking action for double-leaf doors</b>	<b>34</b>
Overview	34
Features and functions	35
SVA/SVI lock system components	36
Dimensions and sections	38
SVA 5000 – Mechanical emergency-escape lock	44
SVA 4000 – Mechanical emergency-escape lock with electrical status monitoring	46
SVA 6000 – Emergency-escape lock with monitoring functions	48
SVA 2000 – Emergency escape motor lock	52
SVA 2000 F – Emergency escape motor lock with PR module for fire/smoke doors	54
SVI 5000 – Mechanical passive door leaf emergency-escape lock	56
SVI 4000 – Mechanical passive door leaf emergency-escape lock with electrical monitoring functions	57
SVI 2000 F – Emergency escape motor lock with PR module for fire/smoke doors	58
<b>M-SVP – Multipoint locking system for single- and double-leaf doors</b>	<b>60</b>
Overview	60
Features and functions	61
Profile-related article overview	62
M-SVP 5000 – Multipoint emergency escape lock with automatic locking action	64
M-SVP 3000 – Multipoint emergency escape lock with automatic locking action	66
M-SVP 2200 DCW® – Multipoint motor lock with automatic locking action and emergency escape function	68
M-SVP 5500 – Multipoint emergency escape lock with automatic locking action for the active door leaf in double-leaf doors	72
M-SVP 3500 – Multipoint emergency escape lock with automatic locking action for the active door leaf in double-leaf doors	74
<b>Accessories for SVx locks</b>	<b>76</b>
SVP-S – Motor lock control units	81
Narrow stile door fitting combinations	84
Timber door fitting combinations	86



Lock doors securely without a key – automatically each time the door is closed. Open closed doors easily from the inside – just by pressing the lever handle.

dormakaba Emergency-escape locks with automatic locking action provide intrusion protection, rapid emergency opening and controlled access. Mechanical, electric or motor-operated.



01



02

## Emergency-escape locks with automatic locking action.

Security in three directions: escape route, intrusion protection and door condition check

### Emergency escape function – door can always be opened quickly from the inside

The doors in an escape route must be able to be opened in the direction of escape using the lever handle, even if the door is locked.

- dormakaba emergency-escape locks can be opened from the inside at any time
- Approved for use in escape routes and in fire and smoke doors
- Certified in accordance with EN 179 or EN 1125

### Break-in protection – door is securely locked from the outside

dormakaba emergency-escape locks with automatic locking action automatically lock doors after each closure.

- Insurance-compliant lock due to 20 mm deadbolt throw and additional engagement of the clawbolt latch (for SVP/SVZ/SVA)
- Increased break-in protection with multipoint locking system (M-SVP)
- Integrated status queries for door surveillance (for electrically connected lock variants)

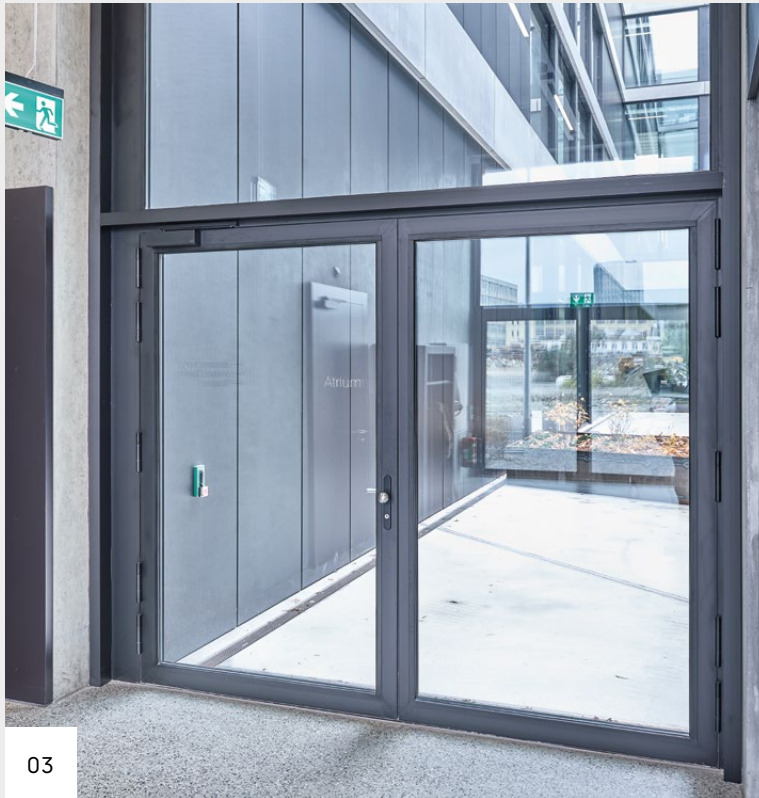

**01**  
Retrofitting of an existing door to escape route door according to EN 179 with purely mechanical SVA 5xxx emergency-escape lock on the active door leaf and SVI 5xxx on the passive door leaf

**02**  
Individual door with emergency-escape lock with automatic locking action SVP 2xxx as escape route door

**03**  
Double-leaf door with TS 93 as escape route with SVA 2xxx F (active door leaf) and SVI 5xxx (passive door leaf)

### Unlocking – authorised entry or exit

Access from the outside is possible at any time via the locking cylinder (normal lock function). Depending on the product variant, further unlocking options can be activated at the lock:

- Access after electrical release, e.g. in access control systems
- Permanent access – with or without actuation of the lever handle depending on the type of lock
- Further control options depending on the lock connection (control unit), such as timer, latch locking during day function or control pulse for an automatic actuator

### Communication – notification of door/lock status

Most locks with automatic locking action can detect and pass on different door/lock statuses.

Depending on the lock variant, the notifications are transmitted as analogue or digital signals (DCW®/CAN bus).

- Lever handle operated
- Door locked or unlocked
- Door open or closed
- Cylinder locking activated
- Additional monitoring functions depending on the connected systems, e.g. switching signal for alarm systems or electrical switch-off of the access control/ input for fire detection system BMA
- All status monitoring detectors are tamper-proof

### Connection – operation as an individual door or as part of a system

Depending on the area of application, a lock can be operated as a "stand-alone solution" or as part of a system, e.g. in conjunction with an automatic actuator (ED 100/ED250) or as part of an emergency exit and escape route system. Depending on the type of lock, different connection options are available:

- Direct analogue
- Via an SVP control unit
- Via DCW® bus, e.g. as part of a SafeRoute emergency exit and escape route system

# Selection guide for emergency-escape locks with automatic locking action – the right lock for every requirement

The dormakaba lock range offers comprehensive solutions for single- and double-leaf timber and profile-framed doors for new and existing door systems.

- Emergency escape function in accordance with EN 179 or EN 1125
- Insurance-compliant lock with two-point locking device via deadbolt and engagement of the clawbolt latch (SVP, SVZ and SVA lock combinations)
- Increased security with multipoint locking systems (M-SVP locks)
- Purely mechanical locks, e.g. for retrofitting existing door systems
- Switch locks, e.g. for monitored doors, in connection with access control systems
- Motor-operated locks, e.g. for barrier-free automatic doors
- All locks available in different versions and locking cylinder types

**01**  
SVP and M-SVP locks for single-leaf doors

**02**  
M-SVP locks and SVA/SVI lock combinations for double-leaf doors



Ordering Assist  
With the dormakaba ordering assist you can easily find the right lock for your door requirements.

<https://svpassist.dormakaba-tools.de/en-GB/>



## Selection guide for a single-leaf door

Essential requirement: The door can always be opened from the inside (emergency escape function) and locks automatically after each closure (insurance-compliant lock).

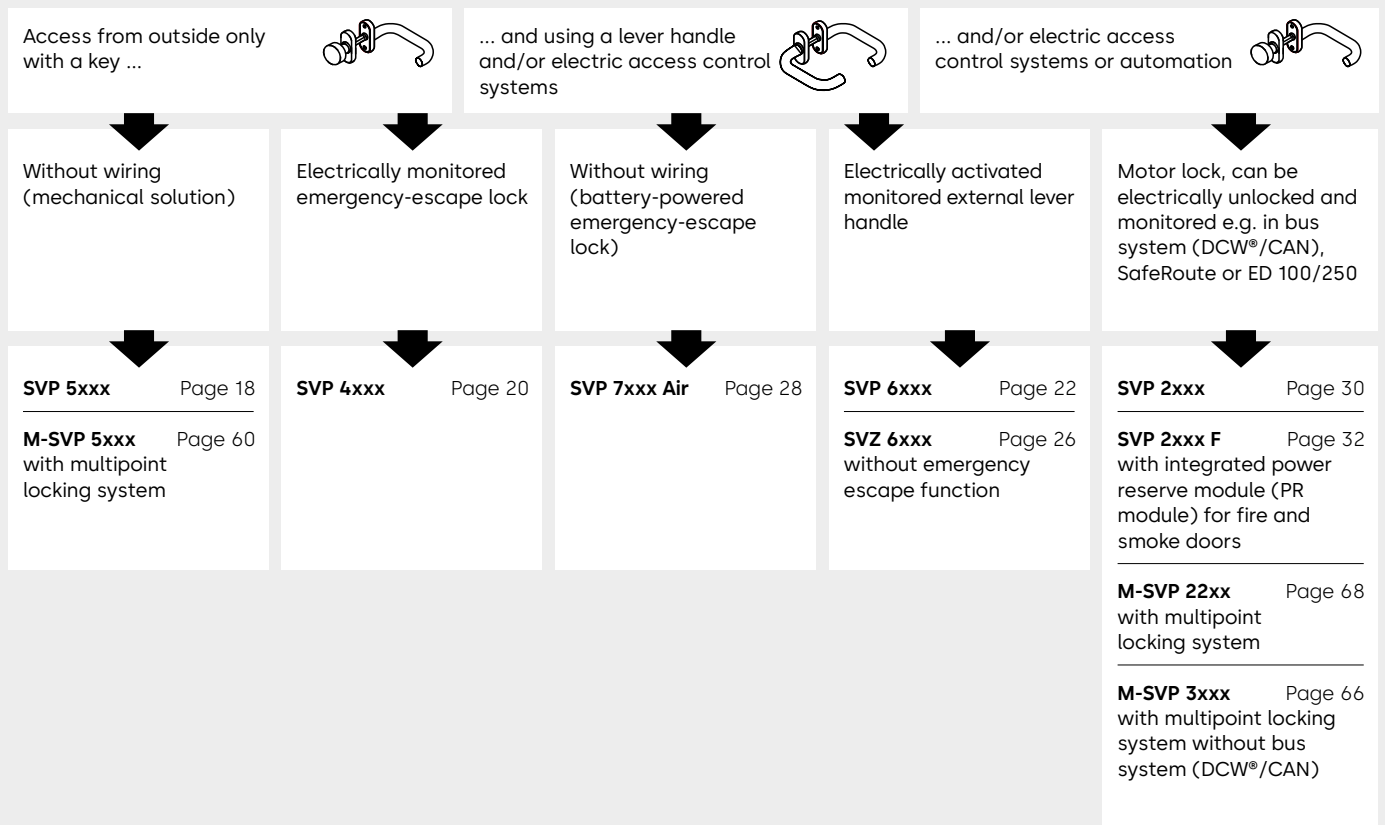



01



02



### Selection guide for double-leaf doors

Essential requirement: The door can always be opened from the inside (emergency escape function) and locks automatically after each closure (insurance-compliant lock).

#### Step 1: Determine the lock for the active door leaf

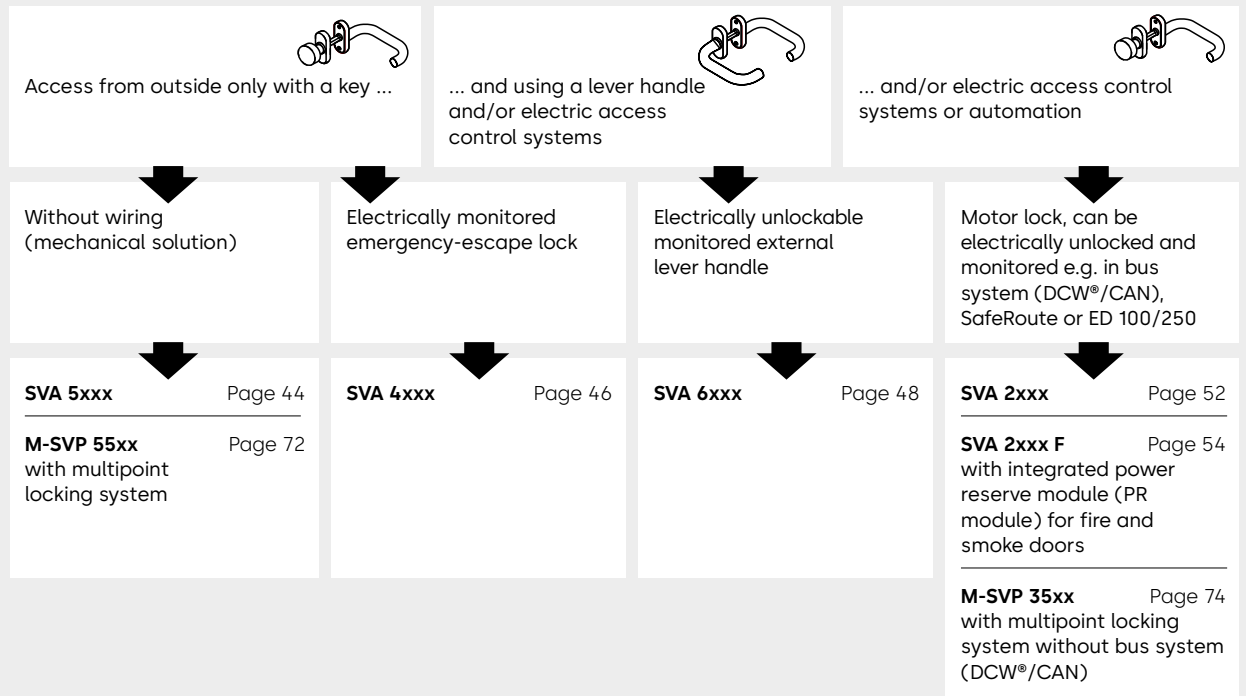

#### Step 2: Select the lock for the passive door leaf depending on the active leaf lock

Possible combinations SVA active door leaf locks/SVI passive door leaf locks				
<b>SVA 5xxx</b>	●	○	-	-
<b>SVA 4xxx / SVA 6xxx</b>	●	●	-	-
<b>SVA 2xxx / SVA 2xxx F</b>	●	●	●	-
<b>M-SVP 35xx / 55xx</b>	-	-	-	●
	<b>SVI 5xxx</b> Without wiring (mechanical solution) Page 56	<b>SVI 4xxx</b> Electrically monitored emergen- cy-escape lock Page 57	<b>SVI 2xxx F</b> Motor lock, can be electrically unlocked and monitored e.g. in bus system (DCW®/ CAN), SafeRoute or ED 100/250 Page 58	<b>M-SVP-GK</b> Without wiring (mechanical solution)
● Compatible    ○ Optional    - Not possible				

## SVP/SVZ – SVP/SVZ emergency-escape locks with automatic locking action for single-leaf doors

- Automatic and immediate locking of doors after each closure
- Insurance-compliant locking with 20 mm deadbolt throw
- Two-point locking via latch bolt and engagement of the clawbolt latch
- The emergency escape function allows you to open the door in the escape direction at any time by operating the lever handle (not SVZ)
- Can be used on wide and narrow stile doors, for profile and round cylinders
- 24 mm forend width, use in left-handed/ right-handed design
- Corrosion-protected lock case
- Faceplate and strike plate made of stainless steel. Strike plate is included in shipment



### SVP 5000

- Purely mechanical lock with emergency escape function

### SVP 4000

- An electrically-monitored panic lock
- With integrated manipulation-protected detectors for monitoring latches, cylinders, handles and latch bolts

### SVP 6000

- An electrically-monitored panic lock with a split follower for the electrical engagement/disengagement the outside handle and manipulation-protected detectors
- Status message for trip latch, bolt, cylinder locking and lever handle

### SVZ 6000

- Access control lock, like the SVP 6000 but without an emergency escape function

### SVP 2000

- Motor lock with manipulation-protected detectors and sequential control for the highest security
- Status message for trip latch, bolt, cylinder locking and lever handle
- Direct connection to dormakaba ED swing door drives or a SafeRoute escape route security system

### SVP 2000 F

- Motor lock with integrated power reserve module (PR module) for fire and smoke doors and with manipulation-protected detectors
- Status message for lock rod and lever handle
- Direct connection to dormakaba ED swing door drives or a SafeRoute escape route security system
- With integrated PR module for use in fire and smoke doors

### SVP 7000 Air

- Electrical battery-powered switch lock with split follower for electrical engagement and disengagement of the outside lever handle

## F Certificate of suitability

The SVP/SVZ locks with automatic locking action have been approved and quality-tested by the notified body MPA in Dortmund.  
An approval or verification of suitability in conjunction with the respective fire and smoke door may be required.



The SVP locks in combination with lever handles and panic bars from various manufacturers have been certified according to EN 179 "Emergency exit devices operated by a lever handle or push pad" and EN 1125 "Panic exit devices operated by a horizontal bar", and therefore carry the CE mark of conformity CE.

### Features and functions SVP/SVZ emergency-escape locks with automatic locking action for single-leaf doors

		SVP 5000	SVP 4000	SVP 6000	SVZ 6000	SVP 2000	SVP 2000 F	SVP 7000 Air
		Page 18	Page 20	Page 22	Page 26	Page 30	Page 32	Page 28
<b>Approvals</b>	Fire and smoke doors	●	●	●	●	● <sup>2)</sup>	●	●
	DIN EN 179/DIN EN 1125	●	●	●	-	●	●	●
<b>Emergency escape functions</b>	Door opening from inside via lever handle/pushbar	●	●	●	-	●	●	●
	Forced closure function (C)	-	-	●	-	-	-	●
	Panic function (E) with knob/lever set	●	●	-	-	●	●	-
<b>Unlock</b>	From outside with key	●	●	●	●	●	●	●
	From outside via lever handle after electrical release (integration in access control systems)	-	-	●	●	-	-	●
	- Automatic reset of the release when the door fails to open	-	-	●	●	●	●	●
	- Adjustable unlock or relock time	-	-	-	-	●	●	-
	- Permanent door release	-	-	-	-	● <sup>3)</sup>	● <sup>5)</sup>	-
	Permanent access possible <sup>1)</sup>	-	-	●	●	-	-	●
	Motor lock (suitable for automatic doors)	-	-	-	-	●	●	-
	Automatic switching off of permanent open/permanent door release if there is a power failure	-	-	●	●	○ <sup>3)</sup>	○ <sup>3) 5)</sup>	-
	Suitable for electronic cylinders	●	●	●	●	●	●	●
<b>Monitoring</b>	Message "Door open/closed"	-	●	●	●	●	●	-
	Message "Door locked/unlocked"	-	●	●	●	●	●	-
	Message "Lever handle operation/emergency escape function"	-	●	●	●	●	●	-
	Message "Cylinder locking"	-	●	●	●	●	●	-
	Sabotage line	-	●	●	●	●	●	-
	DCW®/CAN bus interface	-	-	-	-	●	●	-
	Enabled SafeRoute® components	●	●	●	●	●	●	●
<b>Break-in protection</b>	Insurance compliant locking (dual-point locking device)	●	●	●	●	●	●	●
	Latch bolts	-	-	-	-	-	-	●
	Mechanical self-locking	●	●	●	●	●	●	●
<b>Mode of operation</b>	Mechanical (without wiring)	●	-	-	-	-	-	-
	battery-operated	-	-	-	-	-	-	●
	Mechanical with electrical monitoring	-	●	●	●	●	●	●
	Motorized unlocking	-	-	-	-	●	●	-
	Outside and inside lever handle simultaneously electric engageable / disengageable	-	-	-	●	-	-	-
	Outside handle electrically engageable/disengageable	-	-	●	-	-	-	●
<b>Miscellaneous</b>	Mechanical process control	●	●	●	●	●	●	●
	Electronic sequential control	-	-	-	-	●	●	-

● Yes – No ○ Optional

<sup>1)</sup> PERMANENT OPEN function also permissible on fire and smoke doors, as the doors have a tumbler in case of a fire.

<sup>2)</sup> For fire and smoke doors in conjunction with the PR module (emergency power storage).

<sup>3)</sup> In fire and smoke doors not approved for permanent door release, as tumbler is not guaranteed in the event of a fire.

<sup>4)</sup> In combination with SVP-S Air or via hand-held transmitter.

<sup>5)</sup> Only in combination with the ED 100/250, the SVP-S 4x control unit (firmware 4.7 and higher) or SafeRoute (firmware 1.9).

## SVP 2xxx/4xxx/5xxx/6xxx earth connection for timber doors

Attention: France version (SVP 424X/524X/624X) different earth connection

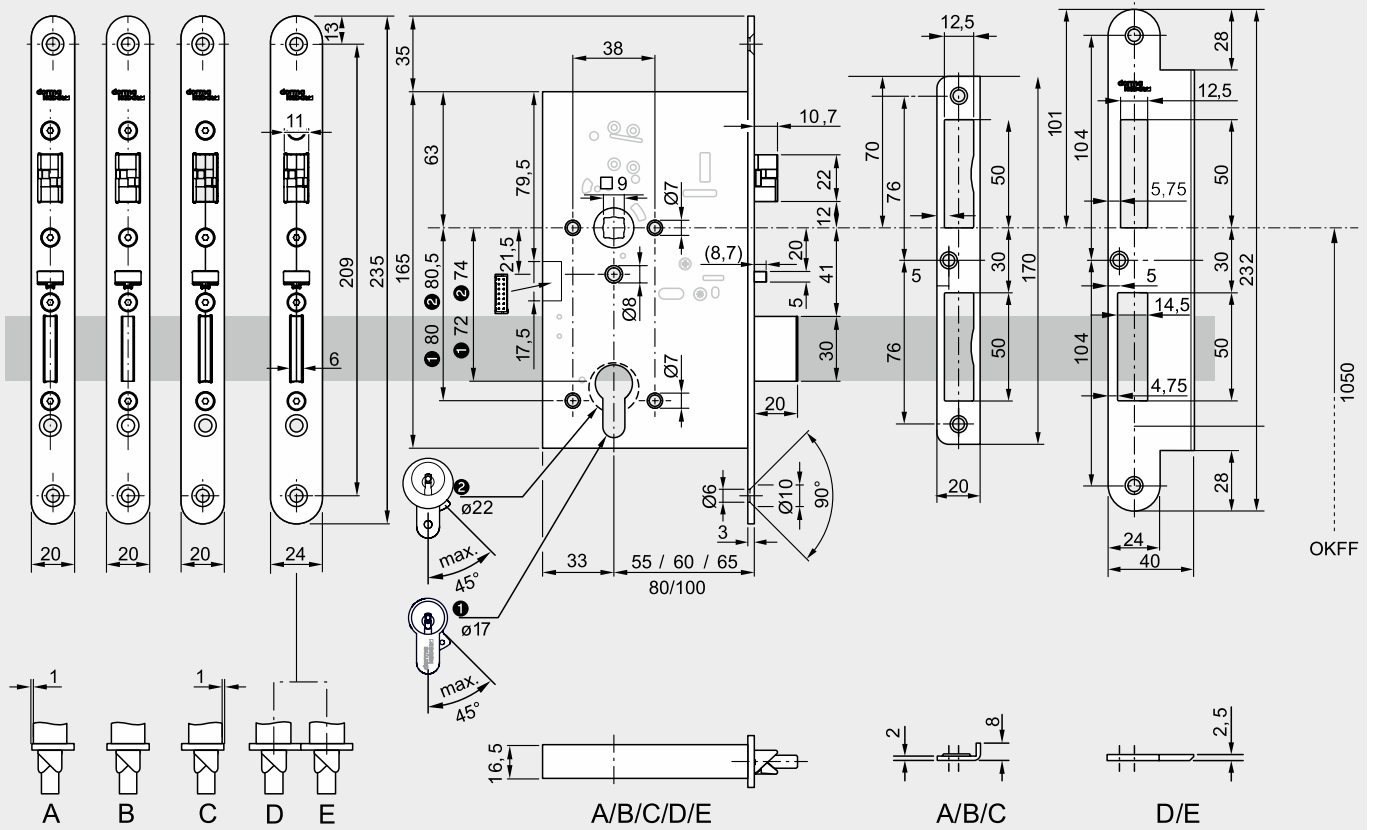

## Rebated door section SVP 2xxx/4xxx/5xxx/6xxx

Attention: France version (SVP 424X/524X/624X) different earth connection

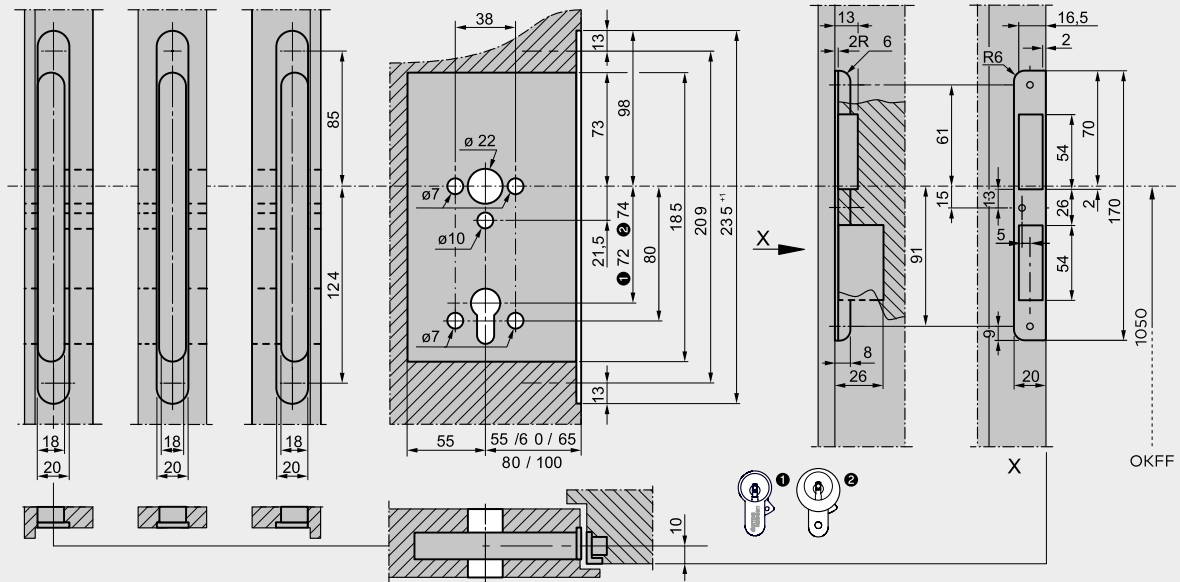

## Non-rebated door section SVP 2xxx/4xxx/5xxx/6xxx

Attention: France version (SVP 424X/524X/624X) different earth connection

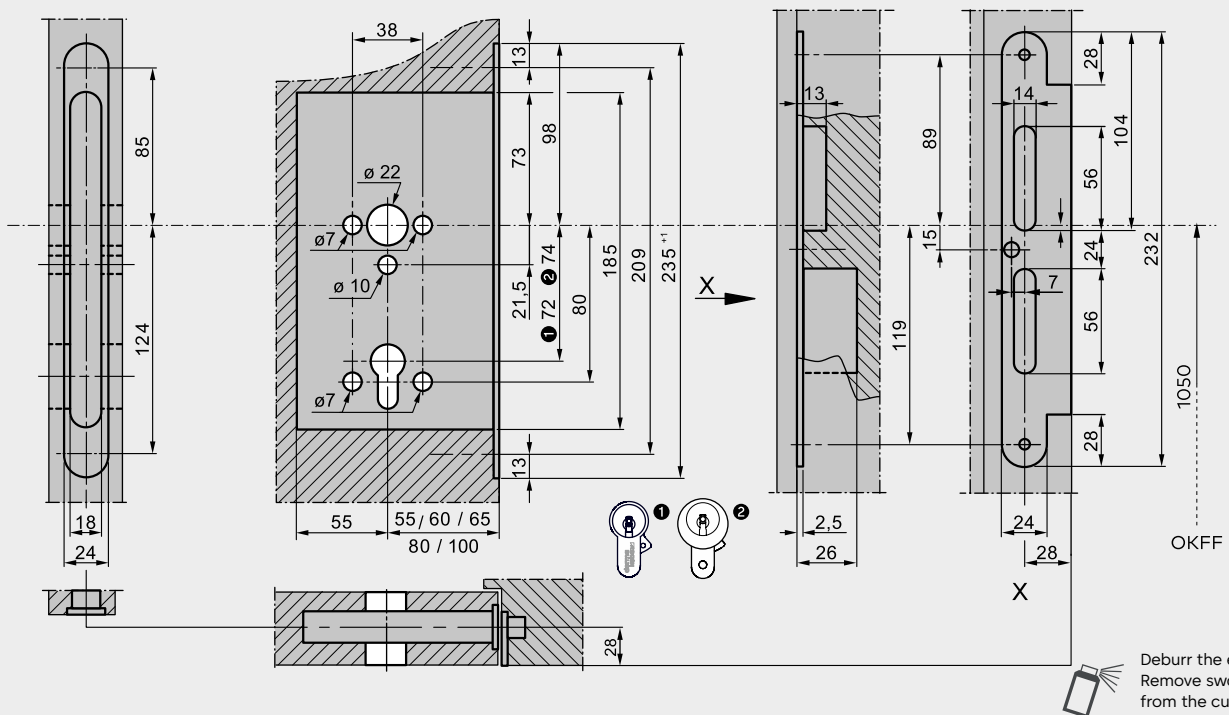

## SVP 424X/524X/624X earth connection (France version) for timber doors

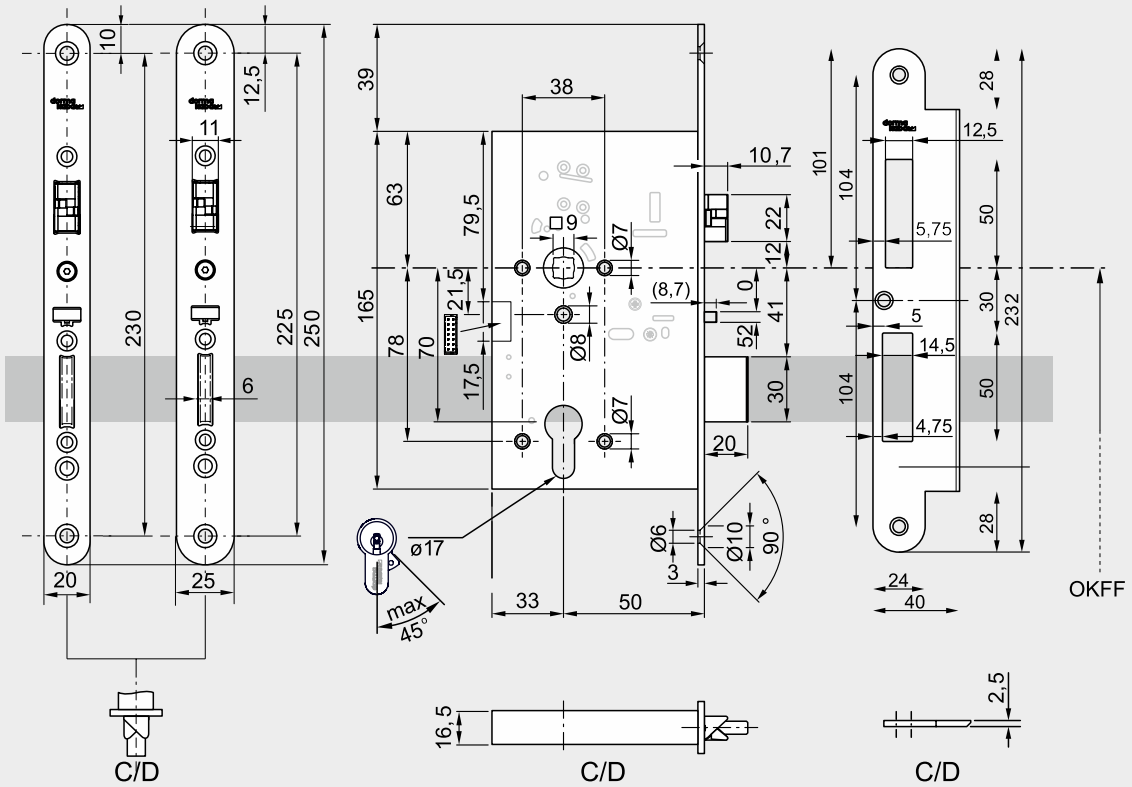

**Non-rebated door section  
SVP 424X/524X/624X (France version)**

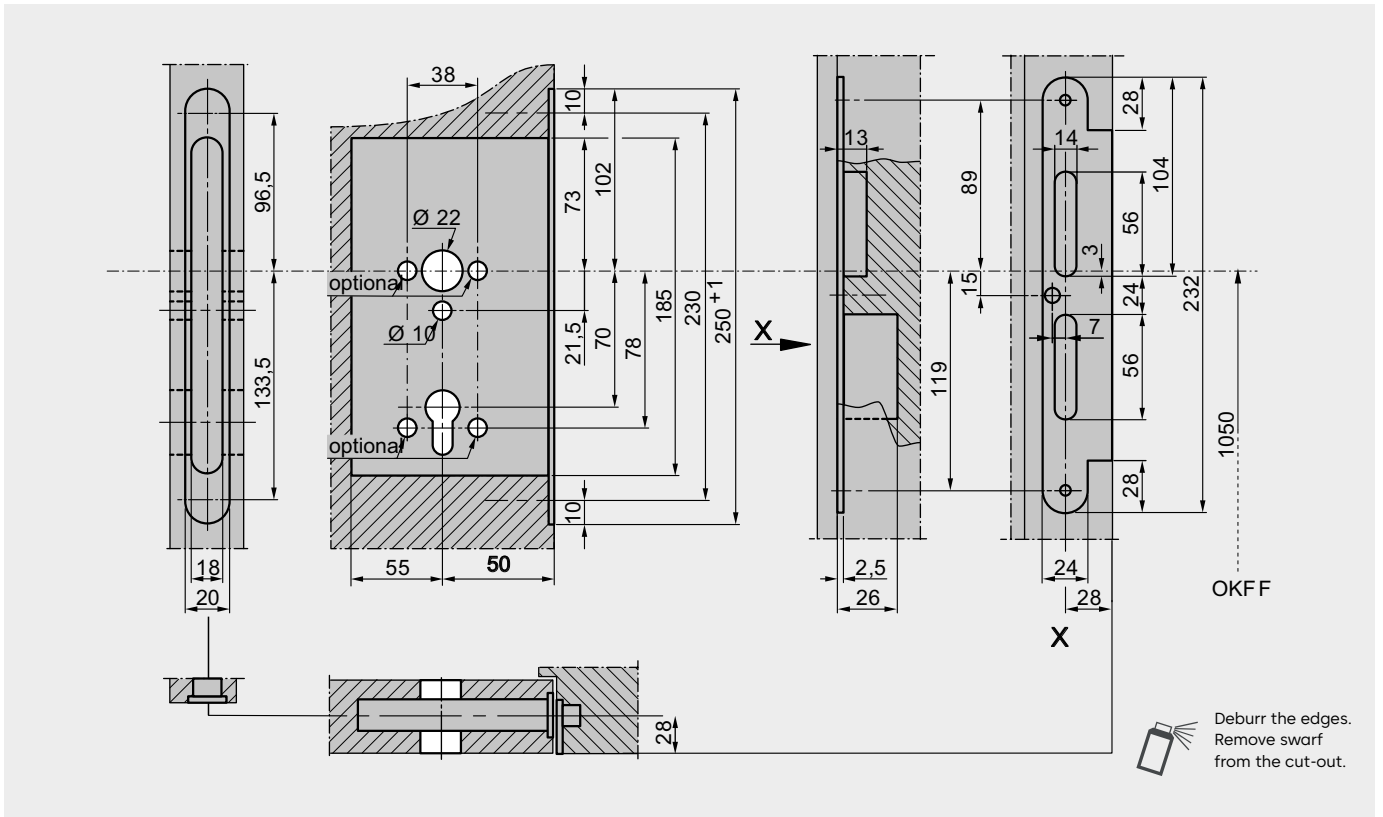

**Non-rebated door section  
SVP 424X/524X/624X (France version)**

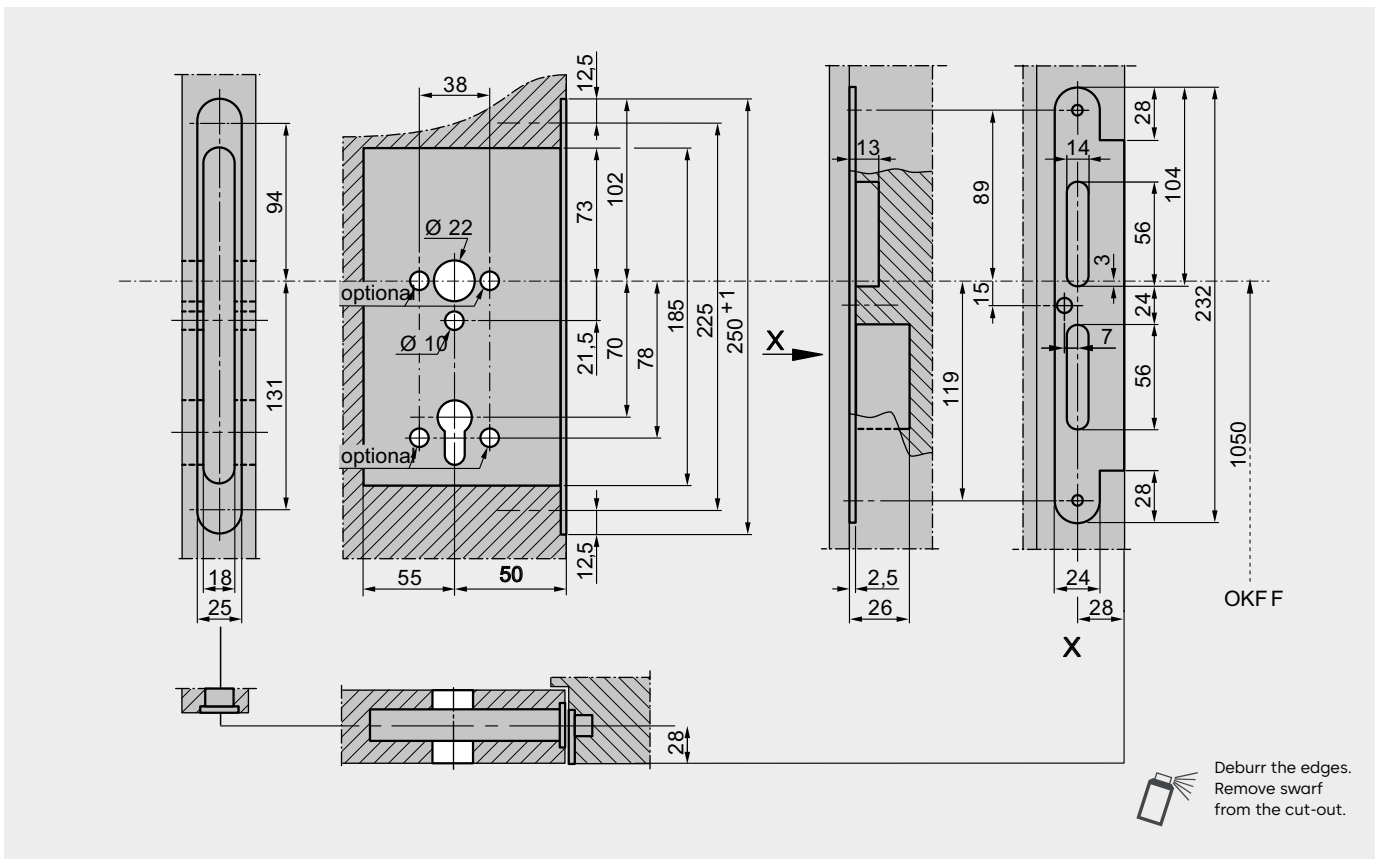

## Dimensions and sections SVP 2xxx/4xxx/5xxx/6xxx for narrow stile doors

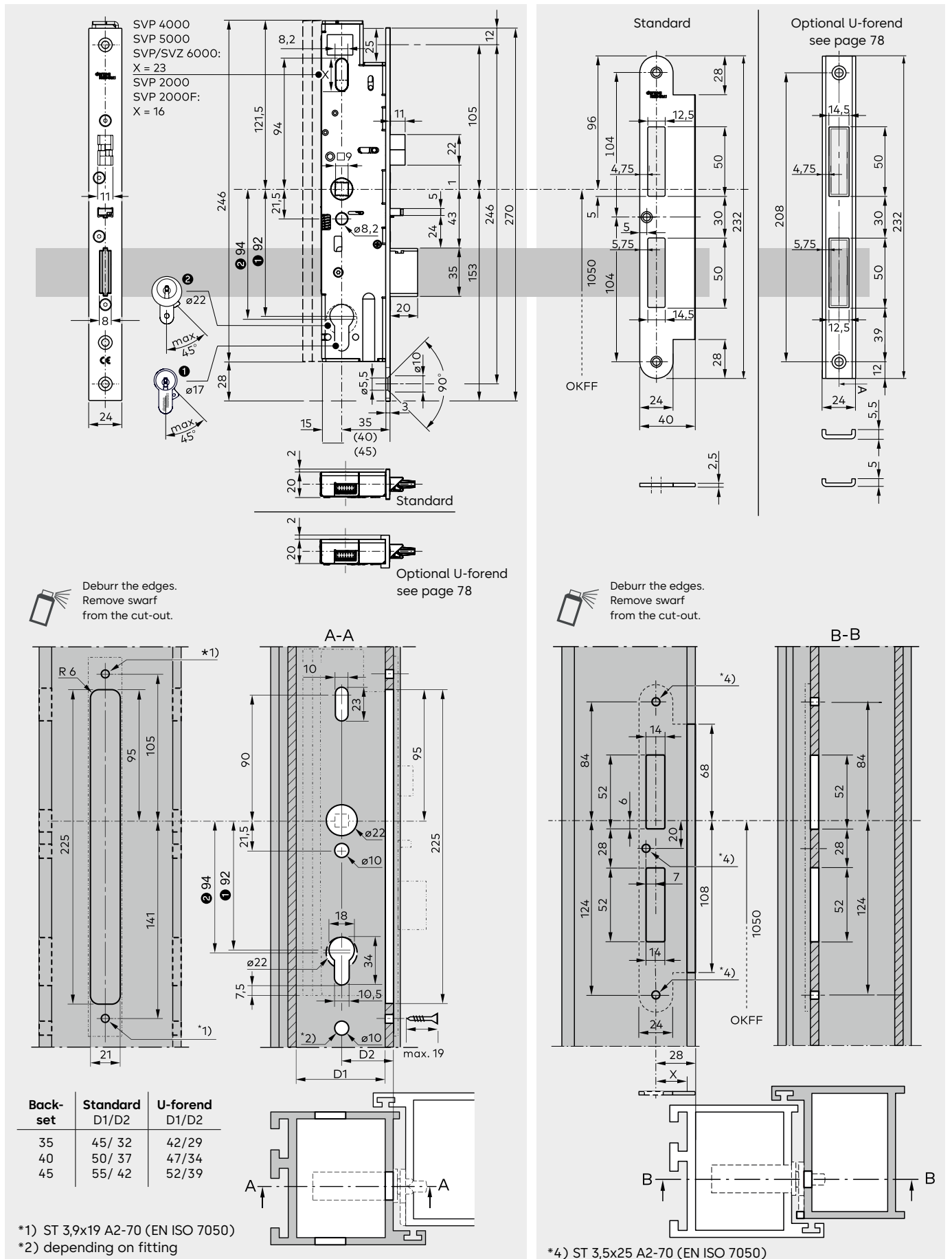

# Dimensions SVP 7xxx Air for timber doors

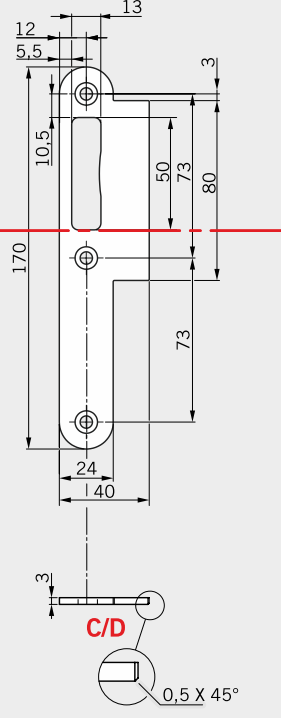
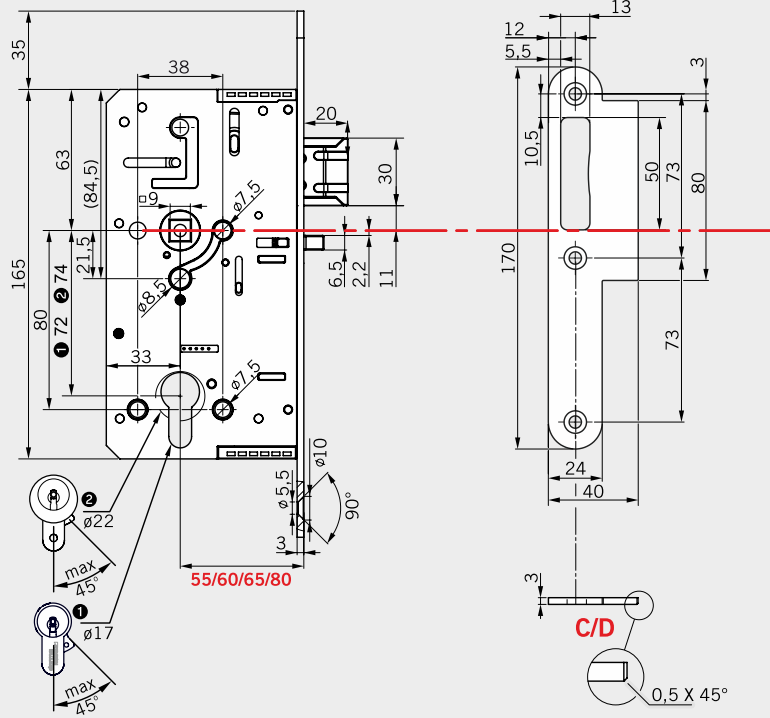
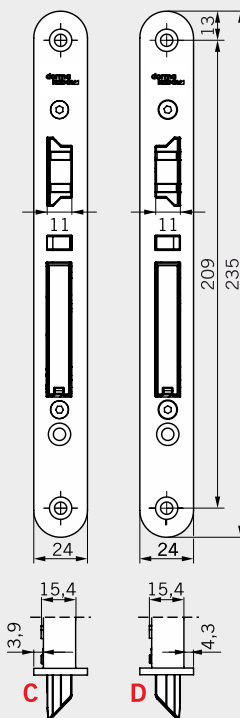
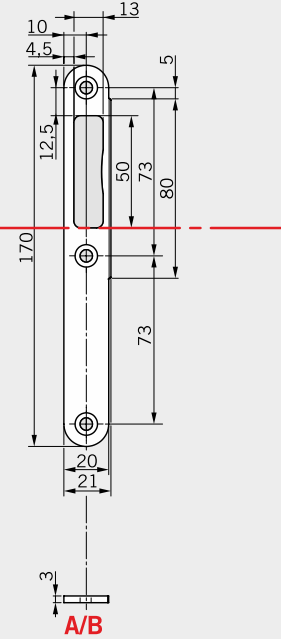
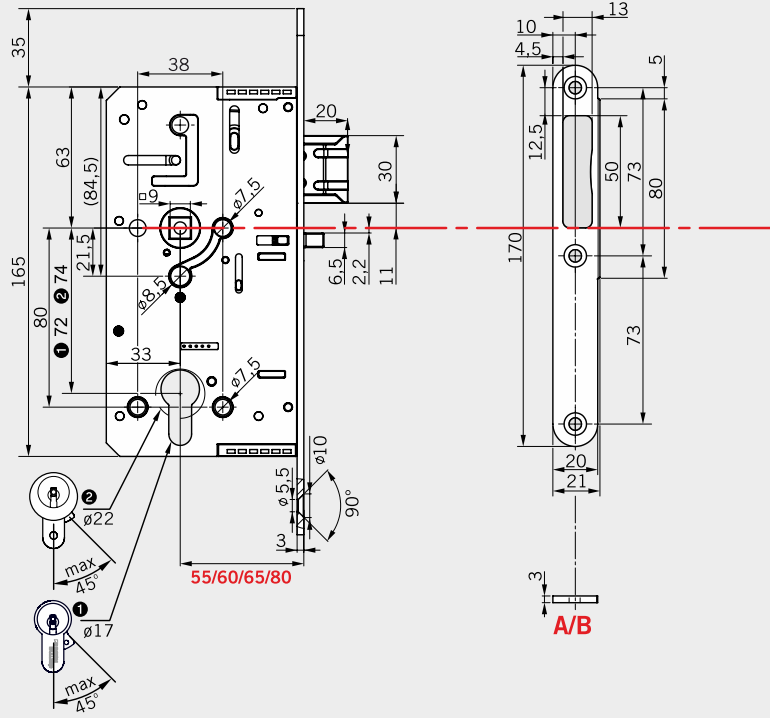
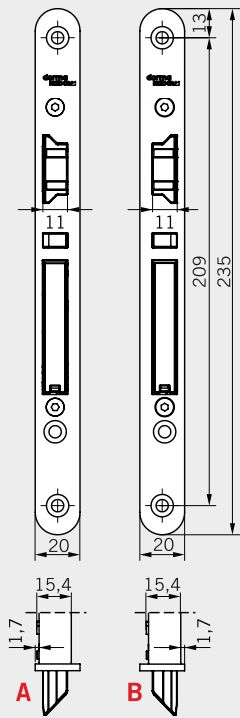
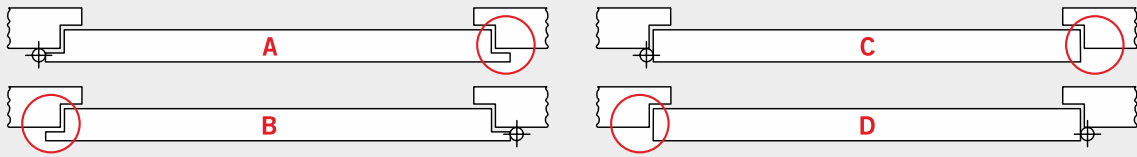

## SVP 5000 – Emergency-escape lock with automatic locking action

### SVP 5xxx

Panic lock with automatic locking action and optimised mechanical sequential control. Two-point locking activated by pre-loaded spring when door closes. Non-handed trigger (24 mm forend versions can be used DIN L/R), panic unlocking via lever handle, change to unlocking function with key access from the outside. Steel bolt, projection 20 mm. 9 mm square-section follower. Corrosion-protected lock case in DIN dimensions, complete with forend and strike plate in stainless steel, included in delivery. Certified in accordance with EN 179 and EN 1125 for use with panic door fittings. Protection against intruders up to resistance class 2 in suitable door systems.

### Installation

- Timber rebated door
- Timber non-rebated door
- Narrow stile door
- DIN left
- DIN right

### perforation

- Profile cylinder PC
  - Round cylinder RC
- B** Backset \_\_\_\_\_ mm

### Other accessories

see Page 76

### Dimensions and installation drawings

see Page 12

### SVP 5xxx locking system

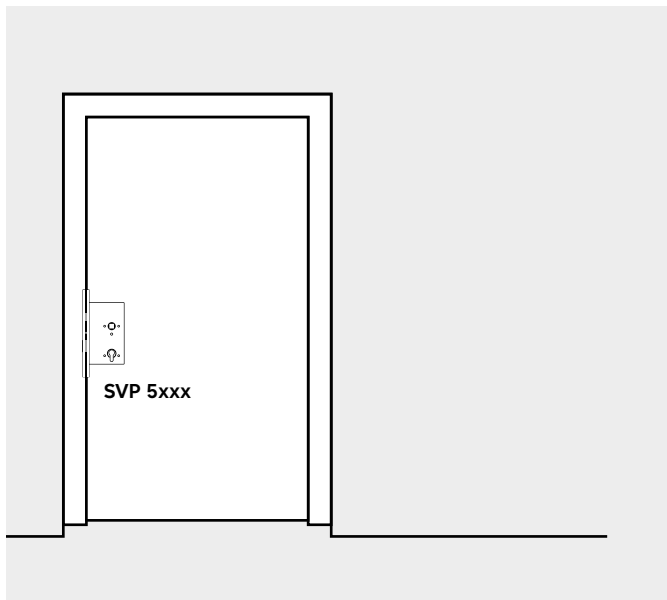

**SVP 5xxx  
for timber doors**

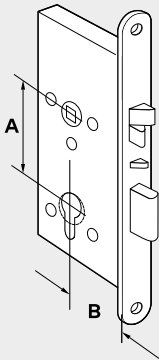

Lock cylinder	Door type	Backset B	DIN	Type	Article no.
PC (A = 70)	Non-rebated door faceplate 250 x 20 (France only)	50	L/R	SVP 5241	70524109
	Non-rebated door faceplate 250 x 25 (France only)	50	L/R	SVP 5247	70524709
PC (A = 72)	Rebated door faceplate: 235 x 20	55	L	SVP 5251	70525100
			R	SVP 5252	70525200
	60	L	SVP 5261	70526100	
		R	SVP 5262	70526200	
	65	L	SVP 5271	70527100	
		R	SVP 5272	70527200	
	80	L	SVP 5281	70528100	
		R	SVP 5282	70528200	
	100	L	SVP 5291	70529100	
		R	SVP 5292	70529200	
	Non-rebated door Forend: 235 x 24	55	L/R	SVP 5257	70525700
		60	L/R	SVP 5267	70526700
		65	L/R	SVP 5277	70527700
		80	L/R	SVP 5287	70528700
100		L/R	SVP 5297	70529700	
RC (A = 74)	Rebated door Forend: 235 x 20	60	L	SVP 5361	70536100
			R	SVP 5362	70536200
	65	L	SVP 5371	70537100	
		R	SVP 5372	70537200	
	80	L	SVP 5381	70538100	
		R	SVP 5382	70538200	
	100	L	SVP 5391	70539100	
		R	SVP 5392	70539200	
	Non-rebated door Forend: 235 x 24	60	L/R	SVP 5367	70536700
		65	L/R	SVP 5377	70537700
80		L/R	SVP 5387	70538700	
100		L/R	SVP 5397	70539700	

All dimension data in millimetres (mm)

PC Profile cylinder RC Round cylinder L DIN left R DIN right

**SVP 5xxx  
for narrow stile doors**

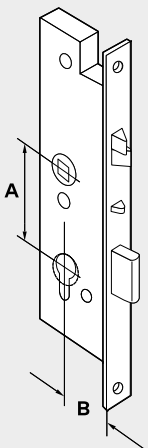

Lock cylinder	Door type	Backset B	DIN	Type	Article no.
PC (A = 92)	Narrow stile door Forend: 270 x 24	35	Universal	SVP 5719	70571900
		40	Universal	SVP 5729	70572900
		45	Universal	SVP 5739	70573900
RC (A = 94)	Narrow stile door Forend: 270 x 24	35	Universal	SVP 5819	70581900
		40	Universal	SVP 5829	70582900
		45	Universal	SVP 5839	70583900

All dimension data in millimetres (mm)

PC Profile cylinder RC Profile round cylinder L DIN-L R DIN-R

# SVP 4000 – Emergency-escape lock with automatic locking action and electrical status monitoring

SVP 4xxx 

Emergency-escape lock with automatic locking action, electric monitoring and optimised mechanical sequential control. With status monitoring for detecting "locked" (> 90%), "unlocked" (< 10% of the latch bolt path), "door open/closed" (via trigger) as well as "handle operation/emergency unlocking" and "cylinder contact". Maximum load current: 30 V DC, 100 mA  
Two-point locking activated by pre-loaded spring when door closes. Non-handed trigger (24 mm forend versions can be used DIN L/R). Emergency unlocking by lever handle, change to unlocking function with key access from the outside. Steel bolt, projection 20 mm. 9 mm square-section follower Corrosion-protected lock case in DIN dimensions, complete with forend and strike plate in stainless steel, included in delivery. Certified in accordance with EN 179 and EN 1125 for use with panic door fittings. Protection against intruders up to resistance class 2 in suitable door systems.

---

Maximum load current            100 mA at max. 30 V DC  
Status messages via potential-free contacts

---

## Installation

- Timber rebated door
- Timber non-rebated door
- Narrow stile door
- DIN left    DIN right

### perforation

- Profile cylinder PC
- Round cylinder RC

**B** Backset \_\_\_\_\_ mm

Required accessories (to be ordered separately):

- dormakaba SVP-A connection cable
- dormakaba cable loop/spiral cable

## Other accessories

see Page 76

## Dimensions and installation drawings

see Page 12

## SVP 4xxx locking system

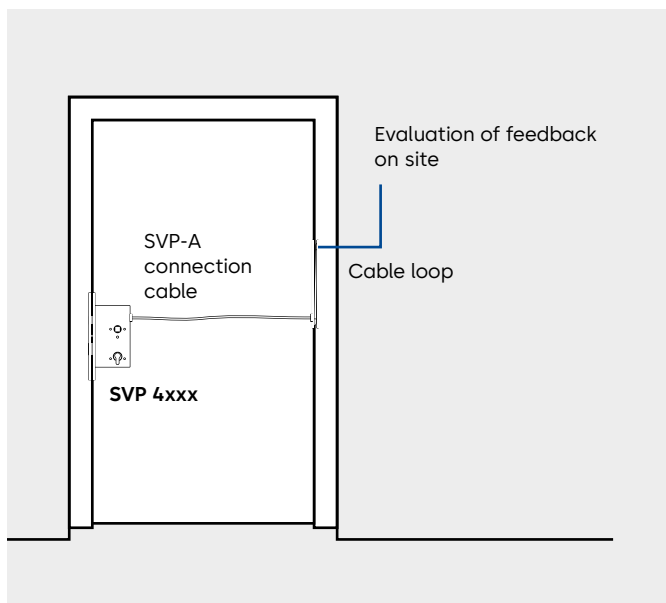

## Wiring layout

### Cable colours SVP 4xxx function

Black	GND
Brown	"Trigger engaged", NC
pink/grey	"SVP unlocked", NO
Red	free
White	free
Yellow	"SVP unlocked" and "Trigger engaged" and cylinder actuated/lock open, C
Green	Cylinder actuated, NO
Grey	Sabotage line
Pink	Sabotage line
red/blue	"SVP locked", NC
Blue	"Handle operated", NO
Violet	"SVP locked" and "Handle operated", C

Evaluation of feedback on site  
(for example, in conjunction with dormakaba SafeRoute)

**SVP 4xxx  
for timber doors**

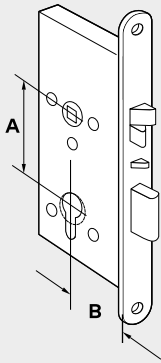

Lock cylinder	Door type	Backset B	DIN	Type	Article no.
PC (A = 70)	Non-rebated door faceplate 250 x 20 (France only)	50	L/R	SVP 4241	70424109
	Non-rebated door faceplate 250 x 25 (France only)	50	L/R	SVP 4247	70424709
PC (A = 72)	Rebated door Forend: 235 x 20	55	L	SVP 4251	70425100
			R	SVP 4252	70425200
	60	L	SVP 4261	70426100	
		R	SVP 4262	70426200	
	65	L	SVP 4271	70427100	
		R	SVP 4272	70427200	
	80	L	SVP 4281	70428100	
		R	SVP 4282	70428200	
	100	L	SVP 4291	70429100	
		R	SVP 4292	70429200	
	Non-rebated door Forend: 235 x 24	55	L/R	SVP 4257	70425700
		60	L/R	SVP 4267	70426700
		65	L/R	SVP 4277	70427700
		80	L/R	SVP 4287	70428700
100		L/R	SVP 4297	70429700	
RC (A = 74)	Rebated door Forend: 235 x 20	60	L	SVP 4361	70436100
			R	SVP 4362	70436200
	65	L	SVP 4371	70437100	
		R	SVP 4372	70437200	
	80	L	SVP 4381	70438100	
		R	SVP 4382	70438200	
	100	L	SVP 4391	70439100	
		R	SVP 4392	70439200	
	Non-rebated door Forend: 235 x 24	60	L/R	SVP 4367	70436700
		65	L/R	SVP 4377	70437700
80		L/R	SVP 4387	70438700	
100		L/R	SVP 4397	70439700	

All dimension data in millimetres (mm)

PC Profile cylinder RC Round cylinder L DIN left R DIN right

**SVP 4xxx  
for narrow stile doors**

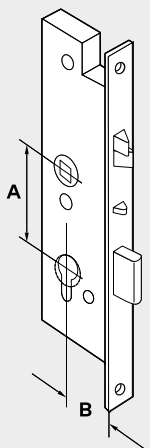

Lock cylinder	Door type	Backset B	DIN	Type	Article no.
PC (A = 92)	Narrow stile door Forend: 270 x 24	35	Universal	SVP 4719	70471900
		40	Universal	SVP 4729	70472900
		45	Universal	SVP 4739	70473900
RC (A = 94)	Narrow stile door Forend: 270 x 24	35	Universal	SVP 4819	70481900
		40	Universal	SVP 4829	70482900
		45	Universal	SVP 4839	70483900

All dimension data in millimetres (mm)

PC Profile cylinder RC Profile round cylinder L DIN-L R DIN-R

## SVP 6000 – Switch-monitored panic lock with automatic locking action

### SVP 6xxx

Microswitch-monitored emergency-escape lock with automatic locking action, versions for narrow stile (67xx/68xx) or timber doors (62xx/63xx), electrically monitored, with split follower, electrically activated outside handle and optimised mechanical sequential control. With status monitoring for detecting "Locked" (> 90%), "Unlocked" (< 10% of the latch bolt path), "door open/closed" (via trip latch) as well as "Lever handle operation/emergency unlocking" and "Cylinder contact". When there is no power, the outside handles are disengaged (operating current) or engaged (closed-circuit current). The outside handle is engaged or disengaged by activating the solenoid (for example, via the access control system). The lever handle is always engaged in the direction of escape. Activation of the outside handle is effected via a GND contact by means of a potential-free NO (operating current) or NC (closed-circuit current). Permanently open mode possible (permanent engagement of outside handle, e.g. for daytime mode). Two-point locking activated by pre-loaded spring when door closes. Non-handed trigger (24 mm forend versions can be used DIN L/R). Unlocking from the outside using key or engaged outside handle. Steel bolt, projection 20 mm. Split 9 mm square-section follower. Corrosion-protected lock case in DIN dimensions, complete with forend and strike plate in stainless steel, included in delivery. Protection against intruders up to resistance class 2 in suitable door systems.

### SVP 62xx/63xx

SVP 6000 version for wide stile doors. Operating or closed-circuit operation universally adjustable at the lock. Connection universal to 12 V DC/24 V DC (stabilised) without previous change-over. Emergency side can be changed over by an authorised personnel with special tools. Certified in accordance with EN 179 and EN 1125 for use with panic door fittings.

### SVP 67xx/68xx

SVP 6000 version for narrow stile doors. Operating current version or closed-circuit current version. Connection universal to 12 V DC/24 V DC (stabilised) without previous change-over. Certified in accordance with EN 179 and EN 1125 for use with panic door fittings.

Supply voltage	12 or 24 V DC stabilised (+/- 10%)
Power input	0.15 A (max. 0.3 A)
Maximum load current	max. 30 V DC, 100 mA
Status messages via potential-free contacts	

### SVP 6xxx locking system

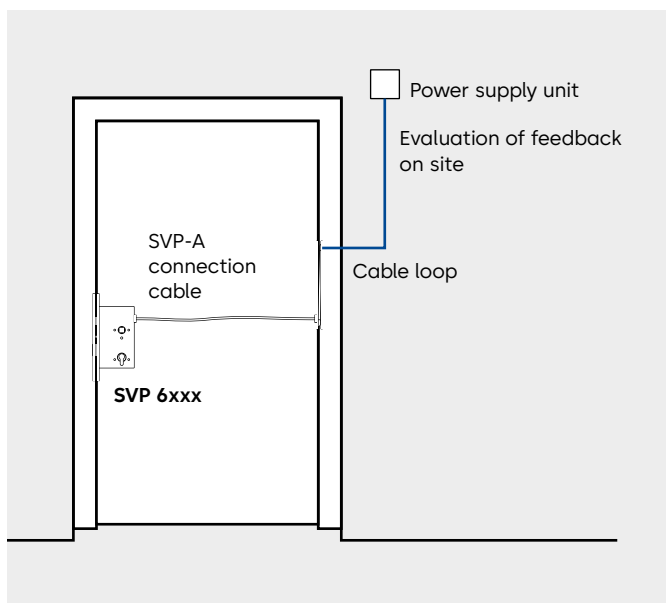

### Wiring layout

#### Cable colours SVP 6xxx function

Black	GND
Brown	"Trigger engaged", NC
pink/grey	"SVP unlocked", NO
Red	Lever handle engaged via GND contact Operating current = NO/Closed-circuit current = NC
White	+12 V DC or +24 V DC (stabilised)
Yellow	"SVP unlocked" and "Trip latch on" and cylinder actuated/lock open, C
Green	Cylinder actuated, NO
Grey	Sabotage line
Pink	Sabotage line
red/blue	"SVP locked", NC
Blue	"Handle operated", NO
Violet	"SVP locked" and "Handle operated", C

Evaluation of feedback on site  
(for example, in conjunction with dormakaba SafeRoute)

**Installation**

- Timber rebated door
- Timber non-rebated door
- Narrow stile door
- DIN left    DIN right

**Escape route opening**

- Escape route opening outwards (normal case)

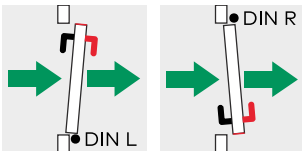

- Escape route opening inwards (special case)

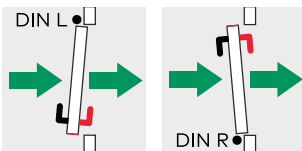

**Door may always be opened in the direction of escape**

- Direction of escape
- Lever handle permanently engaged
- Electrically activated lever handle
- Hinge L/R

perforation

- Profile cylinder PC
- Round cylinder RC
- B** Backset \_\_\_\_\_ mm

- Closed-circuit current (only with narrow stile door, timber door variant is adjustable)
- Operating current (only with the narrow stile door, timber door variant is adjustable)

Required accessories (to be ordered separately):

- dormakaba SVP-A connection cable
- dormakaba cable loop/spiral cable
- dormakaba NT power supply unit

**Other accessories**

see Page 76

**Dimensions and installation drawings**

see Page 12

## SVP 6000 – Switch-monitored panic lock with automatic locking action

**SVP 6xxx  
for timber doors**

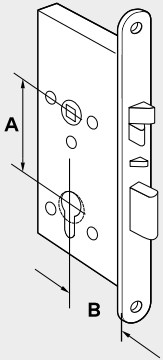

Lock cylinder	Door type	Backset B	Opening	DIN	Type	Article no.
PC (A = 70)	Non-rebated door faceplate 250 x 20 (France only)	50	Outwards/inwards	L/R	SVP 6241	70624109
			Inwards/outwards	L/R	SVP 6242	70624209
	Non-rebated door faceplate 250 x 25 (France only)	50	Outwards/inwards	L/R	SVP 6247	70624809
			Inwards/outwards	L/R	SVP 6248	70624709
PC (A = 72)	Rebated door Forend: 235 x 20	55	Outwards	L	SVP 6251	70625100
			Inwards	R	SVP 6252	70625200
		60	Outwards	L	SVP 6253	70625300
			Inwards	R	SVP 6254	70625400
		65	Outwards	L	SVP 6261	70626100
			Inwards	R	SVP 6262	70626200
	80	Outwards	L	SVP 6263	70626300	
		Inwards	R	SVP 6264	70626400	
	100	Outwards	L	SVP 6271	70627100	
		Inwards	R	SVP 6272	70627200	
	60	Outwards	L	SVP 6273	70627300	
		Inwards	R	SVP 6274	70627400	
	80	Outwards	L	SVP 6281	70628100	
		Inwards	R	SVP 6282	70628200	
	100	Outwards	L	SVP 6283	70628300	
		Inwards	R	SVP 6284	70628400	
	Non-rebated door Forend: 235 x 24	55	Outwards/inwards	L/R	SVP 6291	70629100
			Inwards/outwards	L/R	SVP 6292	70629200
		60	Outwards/inwards	L/R	SVP 6293	70629300
			Inwards/outwards	L/R	SVP 6294	70629400
		65	Outwards/inwards	L/R	SVP 6257	70625700
			Inwards/outwards	L/R	SVP 6258	70625800
		80	Outwards/inwards	L/R	SVP 6267	70626700
			Inwards/outwards	L/R	SVP 6268	70626800
100		Outwards/inwards	L/R	SVP 6277	70627700	
		Inwards/outwards	L/R	SVP 6278	70627800	
60		Outwards/inwards	L/R	SVP 6287	70628700	
		Inwards/outwards	L/R	SVP 6288	70628800	
100	Outwards/inwards	L/R	SVP 6297	70629700		
	Inwards/outwards	L/R	SVP 6298	70629800		
RC (A = 74)	Rebated door Forend: 235 x 20	60	Outwards	L	SVP 6361	70636100
			Inwards	R	SVP 6362	70636200
		65	Outwards	L	SVP 6363	70636300
			Inwards	R	SVP 6364	70636400
		80	Outwards	L	SVP 6371	70637100
			Inwards	R	SVP 6372	70637200
	100	Outwards	L	SVP 6373	70637300	
		Inwards	R	SVP 6374	70637400	
	60	Outwards	L	SVP 6381	70638100	
		Inwards	R	SVP 6382	70638200	
	80	Outwards	L	SVP 6383	70638300	
		Inwards	R	SVP 6384	70638400	
	100	Outwards	L	SVP 6391	70639100	
		Inwards	R	SVP 6392	70639200	
	Non-rebated door Forend: 235 x 24	60	Outwards/inwards	L/R	SVP 6393	70639300
			Inwards/outwards	L/R	SVP 6394	70639400
		65	Outwards/inwards	L/R	SVP 6367	70636700
			Inwards/outwards	L/R	SVP 6368	70636800
		80	Outwards/inwards	L/R	SVP 6377	70637700
			Inwards/outwards	L/R	SVP 6378	70637800
		100	Outwards/inwards	L/R	SVP 6387	70638700
			Inwards/outwards	L/R	SVP 6388	70638800
		60	Outwards/inwards	L/R	SVP 6397	70639700
			Inwards/outwards	L/R	SVP 6398	70639800

All dimension data in millimetres (mm) **PC** Profile cylinder **RC** Profile round cylinder **L** DIN-L **R** DIN-R  
All versions for + 12 V/24 V DC operating current/closed-circuit current

**SVP 6xxx  
for narrow stile doors**

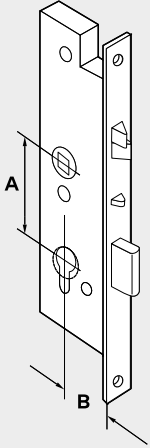

Lock cylinder	Door type	Backset B	Opening/DIN	Type	Article no.
PC (A = 92)	Narrow stile door Forend: 270 x 24	35	R-outwards/L-inwards	SVP6710	706710xx
			L-outwards/R-inwards	SVP6719	706719xx
		40	R-outwards/L-inwards	SVP6720	706720xx
			L-outwards/R-inwards	SVP6729	706729xx
		45	R-outwards/L-inwards	SVP6730	706730xx
			L-outwards/R-inwards	SVP6739	706739xx
RC (A = 94)	Narrow stile door Forend: 270 x 24	35	R-outwards/L-inwards	SVP6810	706810xx
			L-outwards/R-inwards	SVP6819	706819xx
		40	R-outwards/L-inwards	SVP6820	706820xx
			L-outwards/R-inwards	SVP6829	706829xx
		45	R-outwards/L-inwards	SVP6830	706830xx
			L-outwards/R-inwards	SVP6839	706839xx

All dimension data in millimetres (mm)

**PC** Profile cylinder  
**RC** Round cylinder

**xx**

00 – Operating current version (Fail Secure)

50 – Closed-circuit current version (Fail Safe)

**Note:**

In the variant with a 24 mm faceplate, the locks for DIN-L inwards/DIN-R outwards or DIN-R inwards/DIN-L outwards are identical.

**Door may always be opened in the direction of escape**

- ➔ Direction of escape
- ⌵ Lever handle permanently engaged
- ⌴ Electrically activated lever handle
- Hinge L/R

**Opening outwards (normal case)**

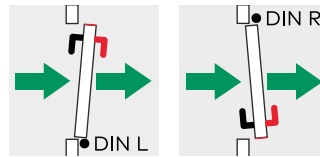

**Opening inwards (special case)**

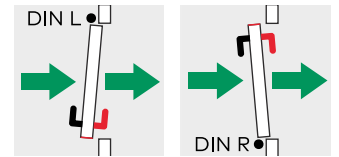

## SVZ 6000 – Automatically locking access control lock

### SVZ 6xxx **F**

Access control lock with automatic locking action, electrically monitored, with single follower, electrically activated lever handle in operating current version or closed-circuit current version, and optimised mechanical sequential control. With status monitoring for detecting "Locked" (> 90% of the latch bolt path), "Unlocked" (< 10% of the latch bolt path), "Door open/closed" via trip latch as well as "Handle operation/cylinder contact". When there is no power, the lever handles are disengaged (operating current) or engaged (closed-circuit current). By means of actuating the solenoid in the lock (e.g. via the access control system), the lever handles can be engaged or disengaged. Activation of the lever handle is effected via a GND contact by means of a potential-free NO (operating current) or NC (short-circuit current). PERMANENTLY OPEN mode possible (permanent engagement of lever handle, e.g. for daytime operation). Two-point locking device activated by pre-loaded spring when door closes. Non-handed trigger (24 mm forend versions can be used DIN L/R). Unlocking with a key or lever handle (lever handle can be engaged). Steel bolt, projection 20 mm. Split 9 mm square-section follower.

Corrosion-protected lock case in DIN dimensions, complete with forend and strike plate in stainless steel, included in delivery. Protection against intruders up to resistance class 2 in suitable door systems.

Supply voltage	universal on 12V DC/24V DC
Power input	0.15 A (max. 0.3 A)
Maximum load current	max. 30 V DC, 100 mA
Status messages via potential-free contacts	

### Installation

- Timber rebated door
- Timber non-rebated door
- Narrow stile door
- DIN left  DIN right

#### perforation

- Profile cylinder PC
- Round cylinder RC
- B** Backset \_\_\_\_\_ mm

- Closed-circuit current (only with narrow stile door, timber door variant is adjustable)
- Operating current (only with the narrow stile door, timber door variant is adjustable)

#### Required accessories (to be ordered separately):

- dormakaba SVP-A connection cable
- dormakaba cable loop/spiral cable
- dormakaba NT power supply unit

### Other accessories

see Page 76

### Dimensions and installation drawings

see Page 12

### SVP 6xxx locking system

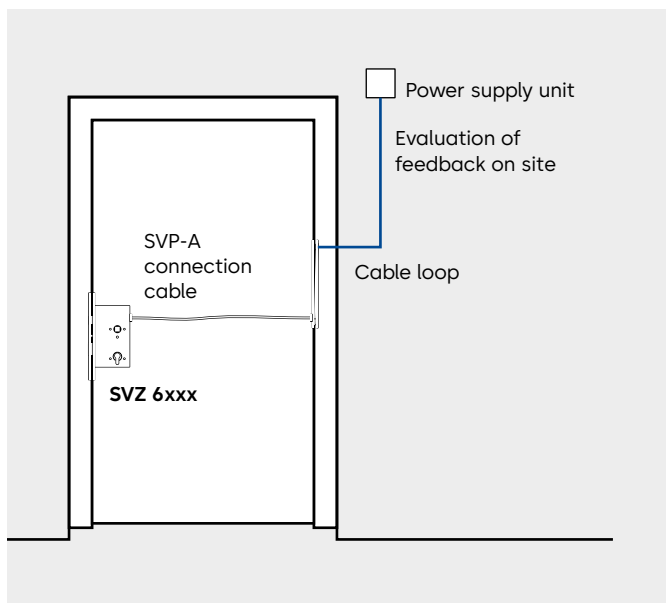

### Wiring layout

#### Cable colours SVZ 6xxx function

Black	GND
Brown	"Trigger engaged", NC
pink/grey	"SVP unlocked", NO
Red	Lever handle engaged via GND contact Operating current = NO/Closed-circuit current = NC
White	+12 V DC or +24 V DC (stabilised)
Yellow	"SVP unlocked" and "Trip latch on" and cylinder actuated/lock open, C
Green	Cylinder actuated, NO
Grey	Sabotage line
Pink	Sabotage line
red/blue	"SVP locked", NC
Blue	"Handle operated", NO
Violet	"SVP locked" and "Handle operated", C

Evaluation of feedback on site  
(for example, in conjunction with dormakaba SafeRoute)

**SVZ 6xxx  
for timber doors**

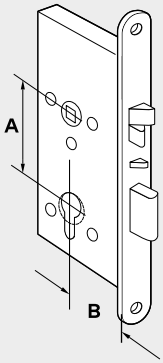

**SVZ 6xxx  
for narrow stile doors**

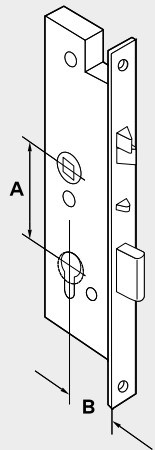

## SVP 7000 Air – The battery-operated panic lock with automatic locking action

### SVP 7xxx Air

Panic lock with automatic locking action for wide stile doors, battery-operated, with split follower and outside handle that can be electrically activated. Operating current. The outside lever handle can be engaged or disengaged via the transfer box SVP-S AIR (integrated in the existing access control system) or the SVP-AIR hand-held transmitter. The lever handle is always engaged in the direction of escape. No wiring of the door required. Short-term unlocking or permanently open modes possible (permanent engagement of outside handle). Programming of up to 99 authorisations. Can change the battery without having to dismantle the lock, secured by the lock cylinder. Steel latch bolt 20 mm projection; 9 mm square-section follower. Corrosion-protected lock case in DIN dimensions, complete with forend and strike plate in stainless steel, included in delivery. Certified in accordance with EN 179, EN 1125

### Installation

- Timber rebated door
- Timber non-rebated door
- DIN left  DIN right

### perforation

- Profile cylinder PC
- Round cylinder RC
- B** Backset \_\_\_\_\_ mm

### Optional accessories (to be ordered separately):

- SVP-S Air universal transfer box
- SVP Air hand-held transmitter

### Other accessories

see Page 80

### Dimensions and installation drawings

see Page 17

### SVP 7xxx Air locking system

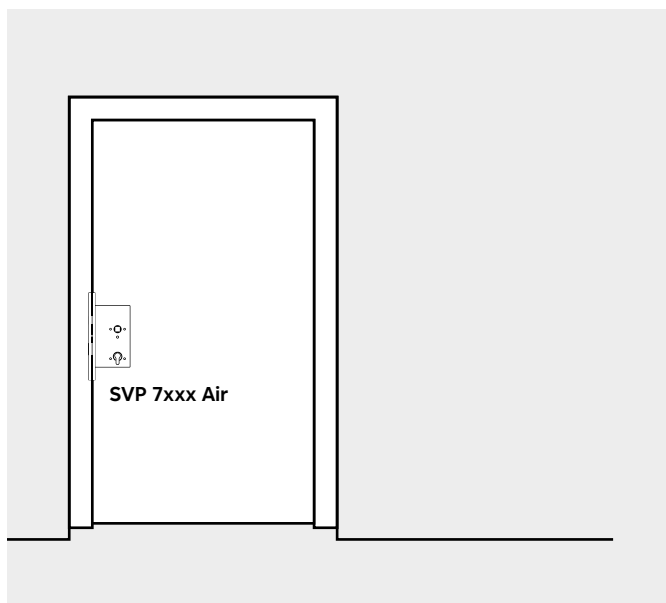

Door may always be opened in the direction of escape

➔ Direction of escape

⌞ Lever handle permanently engaged

⌞ Electrically activated lever handle

● Hinge L/R

Opening outwards (normal case)

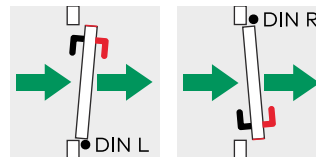

Opening inwards (special case)

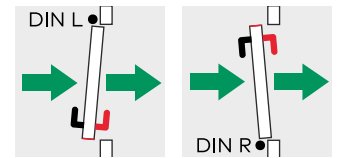

**SVP 7xxx Air  
for timber doors**

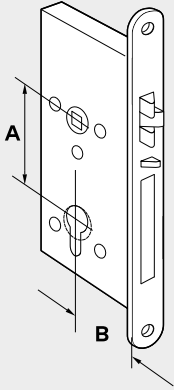

Lock cylinder	Door type	Backset B	Mechanical stop side	DIN	Type	Article no.
PC (A = 72)	Rebated door Forend: 235 x 20	55	outward opening	L	SVP 7251 Air	70725100
			outward opening	R	SVP 7252 Air	70725200
			inward opening	L	SVP 7253 Air	70725300
			inward opening	R	SVP 7254 Air	70725400
		60	outward opening	L	SVP 7261 Air	70726100
			outward opening	R	SVP 7262 Air	70726200
			inward opening	L	SVP 7263 Air	70726300
			inward opening	R	SVP 7264 Air	70626400
		65	outward opening	L	SVP 7271 Air	70727100
			outward opening	R	SVP 7272 Air	70727200
			inward opening	L	SVP 7273 Air	70727300
			inward opening	R	SVP 7274 Air	70727400
	80	outward opening	L	SVP 7281 Air	70728100	
		outward opening	R	SVP 7282 Air	70728200	
		inward opening	L	SVP 7283 Air	70728300	
		inward opening	R	SVP 7284 Air	70728400	
	Non-rebated door Forend: 235 x 24	55	inward opening	L	SVP 7255 Air	70725500
			inward opening	R	SVP 7256 Air	70725600
			outward opening	L	SVP 7257 Air	70725700
			outward opening	R	SVP 7258 Air	70725800
		60	inward opening	L	SVP 7265 Air	70726500
			inward opening	R	SVP 7266 Air	70726600
			outward opening	L	SVP 7267 Air	70726700
			outward opening	R	SVP 7268 Air	70726800
65		inward opening	L	SVP 7275 Air	70727500	
		inward opening	R	SVP 7276 Air	70727600	
		outward opening	L	SVP 7277 Air	70727700	
		outward opening	R	SVP 7278 Air	70727800	
80	inward opening	L	SVP 7285 Air	70728500		
	inward opening	R	SVP 7286 Air	70728600		
	outward opening	L	SVP 7287 Air	70728700		
	outward opening	R	SVP 7288 Air	70728800		
RC (A = 74)	Rebated door Forend: 235 x 20	60	outward opening	L	SVP 7361 Air	70736100
			outward opening	R	SVP 7362 Air	70736200
			inward opening	L	SVP 7363 Air	70736300
			inward opening	R	SVP 7364 Air	70736400
		65	outward opening	L	SVP 7371 Air	70737100
			outward opening	R	SVP 7372 Air	70737200
			inward opening	L	SVP 7373 Air	70737300
			inward opening	R	SVP 7374 Air	70737400
		80	outward opening	L	SVP 7381 Air	70738100
			outward opening	R	SVP 7382 Air	70738200
			inward opening	L	SVP 7383 Air	70738300
			inward opening	R	SVP 7384 Air	70738400
	Non-rebated door Forend: 235 x 24	60	inward opening	L	SVP 7365 Air	70736500
			inward opening	R	SVP 7366 Air	70736600
			outward opening	L	SVP 7367 Air	70736700
			outward opening	R	SVP 7368 Air	70736800
		65	inward opening	L	SVP 7375 Air	70737500
			inward opening	R	SVP 7376 Air	70737600
			outward opening	L	SVP 7377 Air	70737700
			outward opening	R	SVP 7378 Air	70737800
		80	inward opening	L	SVP 7385 Air	70738500
			inward opening	R	SVP 7386 Air	70738600
			outward opening	L	SVP 7387 Air	70738700
			outward opening	R	SVP 7388 Air	70738800

All dimension data in millimetres (mm) PC Profile cylinder RC Profile round cylinder L DIN-L R DIN-R

# SVP 2000 – Emergency escape motor lock with automatic locking action

## SVP 2xxx

Motorised emergency-escape lock with automatic locking action and optimised mechanical and electronic sequential control. Possible operation modes: direct by analogue actuation, with external control unit SVP-S 3x (Switzerland) and SVP-S 4x (with full functionality) or via DCW® bus to SafeRoute and/or ED 100/250. LED status display shows error messages, such as incorrect operating voltage or bus connection interrupted and more! With status monitoring for detecting "Locked" (> 90%), "Unlocked" (< 10% of the latch bolt path), "Door open/closed" (via trip latch) as well as "Handle operation/emergency unlocking" and "Cylinder contact". Two-point locking activated by pre-loaded spring when door closes. Universal trip latch (24 mm faceplate versions can be used LH or RH). Emergency unlocking using lever handle in accordance with EN 179 or panic bar in accordance with EN 1125 as well as a transmission function for unlocking from the outside using keys. Steel bolt 20 mm projection, 9 mm square-section follower. Corrosion-protected lock case in DIN dimensions, complete with forend and strike plate in stainless steel, included in delivery. Protection against intruders up to resistance class 2 in suitable door systems.

**F** For fire and smoke doors only in conjunction with the PR module (emergency power storage).

Supply voltage	24 V DC stabilised (+/- 15%)
Power input	0.05 A (max. 0.3 A)
Bus operation	DCW® bus or CAN bus (ISO 11898-3)
"Locked" signal:	Output switches to GND, 30 mA at max. 30 V DC

### SVP 2xxx locking system

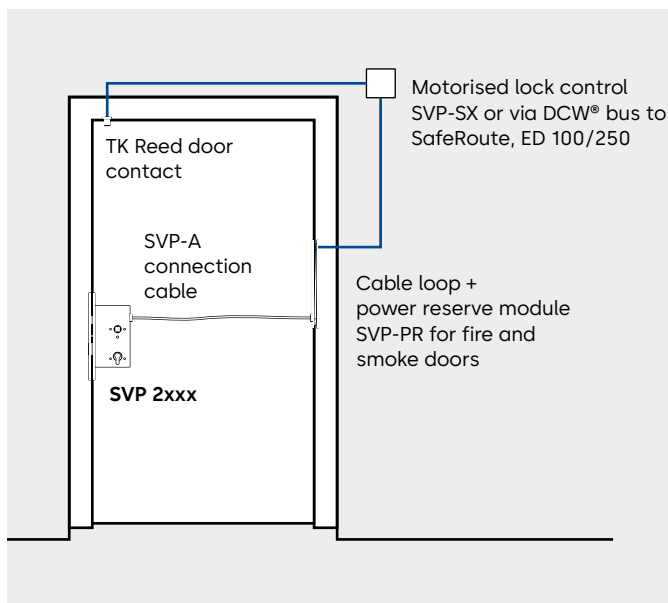

### Version

- Timber rebated door (angled strike plate)
- Timber non-rebated door (lipped strike plate)
- Narrow stile door (lipped strike plate)
- DIN left  DIN right

### perforation

- Profile cylinder PC  Round cylinder RC

**B** Backset \_\_\_\_\_ mm

### Required accessories (to be ordered separately):

- dormakaba SVP-A connection cable
- dormakaba cable loop/spiral cable
- dormakaba TK Reed door contact
- for dormakaba SVP-PR fire doors

### Control via

- dormakaba SVP-S3x (CH)/S4x DCW® Motor lock control unit
- SafeRoute
- Automatic operator ED 100/250

### Other accessories

see Page 76

### Dimensions and installation drawings

see Page 12

### Wiring layout

Cable colours	SVP 2xxx function		
	CAN	Stand-alone	DCW (SVP-S3x, S4x, SafeRoute, TMS or ED 100/250)
Black	GND (3)	GND (3)	GND (3)
Brown	–	–	–
pink/grey	–	–	–
Red	–	Unlock SVP via GND – contact	–
White	+24 V DC (1)	+24 V DC (1)	+24 V DC (1)
Yellow	CAN L	–	A (DCW® data)
Green	CAN H	–	B (DCW® data)
Grey	–	–	–
Pink	–	–	–
red/blue	–	–	–
Blue	–	Door contact via GND contact	–
Violet	SVP locked	SVP locked 30 mA Out	SVP locked 30 mA Out

– Not assigned

**SVP 2xxx  
for timber doors**

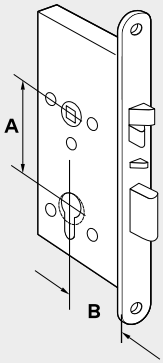

Lock cylinder	Door type	Backset B	DIN	Type	Article no.	
PC (A = 70)	Non-rebated door faceplate 250 x 20 (France only)	50	L/R	SVP 2241	70224109	
		50	L/R	SVP 2247	70224709	
PC (A = 72)	Rebated door Forend: 235 x 20	55	L	SVP 2251	70225100	
			R	SVP 2252	70225200	
		60	L	SVP 2261	70226100	
			R	SVP 2262	70226200	
		65	L	SVP 2271	70227100	
			R	SVP 2272	70227200	
		80	L	SVP 2281	70228100	
			R	SVP 2282	70228200	
		100	L	SVP 2291	70229100	
			R	SVP 2292	70229200	
		Non-rebated door Forend: 235 x 24	55	L/R	SVP 2257/2258	70225700
			60	L/R	SVP 2267/2268	70226700
			65	L/R	SVP 2277/2278	70227700
			80	L/R	SVP 2287	70228700
100	L/R		SVP 2297	70229700		
RC (A = 74)	Rebated door Forend: 235 x 20	60	L	SVP 2361	70236100	
			R	SVP 2362	70236200	
		65	L	SVP 2371	70237100	
			R	SVP 2372	70237200	
		80	L	SVP 2381	70238100	
			R	SVP 2382	70238200	
		100	L	SVP 2391	70239100	
			R	SVP 2392	70239200	
		Non-rebated door Forend: 235 x 24	60	L/R	SVP 2367/2368	70236700
			65	L/R	SVP 2377/2378	70237700
80	L/R		SVP 2387	70238700		
100	L/R		SVP 2397	70239700		

All dimension data in millimetres (mm)

PC Profile cylinder RC Round cylinder L DIN left R DIN right

**SVP 2xxx  
for narrow stile doors**

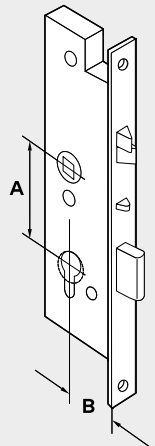

Lock cylinder	Door type	Backset B	DIN	Type	Article no.
PC (A = 92)	Narrow stile door Forend: 270 x 24	35	Universal	SVP 2719	70271900
		40	Universal	SVP 2729	70272900
		45	Universal	SVP 2739	70273900
RC (A = 94)	Narrow stile door Forend: 270 x 24	35	Universal	SVP 2819	70281900
		40	Universal	SVP 2829	70282900
		45	Universal	SVP 2839	70283900

All dimension data in millimetres (mm)

PC Profile cylinder RC Round cylinder

# SVP 2000 F – Emergency escape motor lock with automatic locking action and integrated power reserve module for fire and smoke doors

## SVP 2xxx F

Emergency escape motor lock with automatic locking action and optimised mechanical and electronic sequential control. Suitable for fire and smoke doors through an integrated PR module, without permanent door release. Possible operation modes: direct by analogue actuation, with external control unit SVP-S 3x DCW® (Switzerland) and SVP-S 4x DCW® (stand-alone with full functionality) or via DCW® bus to SafeRoute and/or ED. LED status display shows error messages, such as incorrect operating voltage or bus connection interrupted and more! Duisburg function: compatible with all kinds of cylinders, even electronic and free wheel cam cylinders. With status monitoring for detecting "Locked" (> 90%), "Unlocked" (< 10% of the latch bolt path), "Door open/closed" (via trip latch) as well as "Handle operation/emergency unlocking" and "Cylinder contact". Two-point locking activated by pre-loaded spring when door closes. Universal trip latch (24 mm faceplate versions can be used LH or RH). Emergency unlocking using lever handle in accordance with EN 179 or panic bar in accordance with EN 1125, as well as a transmission function for unlocking from the outside using keys. Steel latch bolt 20 mm projection, 9 mm square-section follower. Corrosion-protected lock case in DIN dimensions, complete with forend and strike plate in stainless steel, included in delivery. Connection to 24 V. Uniform connection using the SVP-A 1100 connection cable (to be ordered separately). Protection against intruders up to resistance class 2 in suitable door systems.

Supply voltage	24 V DC stabilised (+/- 15%)
Power input	0.05 A (max. 0.3 A)
Bus operation	DCW® bus or CAN bus (ISO 11898-3)
"Locked" signal:	Output switches to GND, 30 mA at max. 30 V DC

### SVP 2xxx F locking system

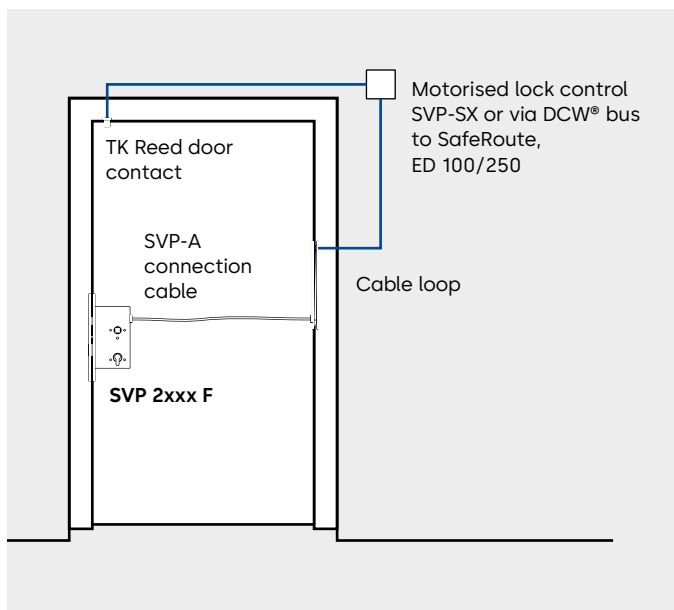

### Installation

- Timber rebated door (angled strike plate)
- Timber non-rebated door (lipped strike plate)
- Narrow stile door (lipped strike plate)
- DIN left  DIN right

### perforation

- Profile cylinder PC  Round cylinder RC

**B** Backset \_\_\_\_\_ mm

### Required accessories (to be ordered separately):

- dormakaba SVP-A connection cable
- dormakaba cable loop/spiral cable
- dormakaba TK Reed door contact

### Control via

- dormakaba SVP-S3x (CH)/S4x DCW® Motor lock control unit
- SafeRoute
- Automatic operator ED 100/250

### Other accessories

see Page 76

### Dimensions and installation drawings

see Page 12

### Wiring layout

Cable colours	SVP 2xxx F function		
	CAN	Stand-alone	DCW (SVP-S3x, S4x, SafeRoute, TMS or ED 100/250)
Black	GND (3)	GND (3)	GND (3)
Brown	–	–	–
pink/grey	–	–	–
Red	–	Unlock SVP via GND – contact	–
White	+24 V DC (1)	+24 V DC (1)	+24 V DC (1)
Yellow	CAN L	–	A (DCW® data)
Green	CAN H	–	B (DCW® data)
Grey	–	–	–
Pink	–	–	–
red/blue	–	–	–
Blue	–	Door contact via GND contact	–
Violet	SVP locked	SVP locked 30 mA Out	SVP locked 30 mA Out

– Not assigned

**SVP 2xxx F  
for timber doors**

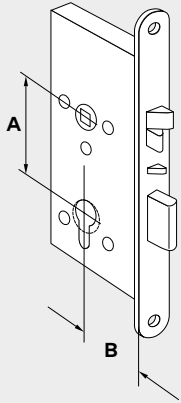

Lock cylinder	Door type	Backset B	DIN	Type	Article no.
PC (A = 70)	Non-rebated door faceplate 250 x 20 (France only)	50	L/R	SVP 2241 F	70224129
	Non-rebated door faceplate 250 x 25 (France only)	50	L/R	SVP 2247 F	70224729
PC (A = 72)	Rebated door Forend: 235 x 20	55	L	SVP 2251 F	70225120
			R	SVP 2252 F	70225220
		60	L	SVP 2261 F	70226120
			R	SVP 2262 F	70226220
		65	L	SVP 2271 F	70227120
			R	SVP 2272 F	70227220
	80	L	SVP 2281 F	70228120	
		R	SVP 2282 F	70228220	
	Non-rebated door Forend: 235 x 24	55	L/R	SVP 2257 F	70225720
			60	L/R	SVP 2267 F
		65	L/R	SVP 2277 F	70227720
		80	L/R	SVP 2287 F	70228720
100		L/R	SVP 2297 F	70229720	
RC (A = 74)		Rebated door Forend: 235 x 20	60	L	SVP 2361 F
R	SVP 2362 F			70236220	
65	L		SVP 2371 F	70237120	
	R		SVP 2372 F	70237220	
80	L		SVP 2381 F	70238120	
	R		SVP 2382 F	70238220	
Non-rebated door Forend: 235 x 24	60	L/R	SVP 2367 F	70236720	
		65	L/R	SVP 2377 F	70237720
	80	L/R	SVP 2387 F	70238720	
	100	L/R	SVP 2397 F	70239720	

All dimension data in millimetres (mm)

PC Profile cylinder RC Profile round cylinder L DIN left R DIN right F Integrated Power reserve module

**SVP 2xxx F  
for narrow stile doors  
in fire/smoke doors**

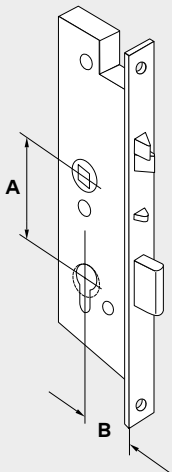

Lock cylinder	Door type	Backset B	DIN	Type	Article no.
PC (A = 92)	Narrow stile door Forend: 270 x 24	35	Universal	SVP 2719 F	70271920
		40	Universal	SVP 2729 F	70272920
		45	Universal	SVP 2739 F	70273920
RC (A = 92)	Narrow stile door Forend: 270 x 24	35	Universal	SVP 2819 F	70281920
		40	Universal	SVP 2829 F	70282920
		45	Universal	SVP 2839 F	70283920

All dimension data in millimetres (mm)

PC Profile cylinder RC Round cylinder F Integrated Power reserve module

# SVA/SVI lock combinations. Emergency-escape locks with automatic locking action for double-leaf doors

The combination of an active door leaf lock (SVA) and a passive door leaf lock (SVI) automatically locks the door every time it is closed. Both the passive and active door leaves can be opened in the direction of escape at any time in accordance with EN 179 or EN 1125.

- Insurance-compliant locking with two-point locking activated via bolt and clawbolt latch on the active door leaf and a rod lock system on the passive door leaf
- Can be used on timber and narrow stile doors, for profile and round cylinders
- Active and passive door leaf locks combinable



## SVA active leaf door lock

### SVA 5000

- Purely mechanical lock with emergency escape function and mechanical sequential control

### SVA 4000

- Electrically monitored emergency-escape lock
- With integrated tamper-proof detectors for monitoring latches, cylinders, handles and latch bolts

### SVA 6000

- Electrically monitored emergency-escape lock with split follower for the electrical engagement/disengagement of the outside lever handle
- Status message for trip latch, bolt, cylinder locking and lever handle

### SVA 2000

- Operation modes for the motor lock: Analogue with control unit, via DCW® or CAN-BUS or autonomously without control unit.
- Status message for trip latch, bolt, cylinder locking and lever handle
- Direct connection to dormakaba ED swing door drives or a SafeRoute escape route security system

### SVA 2000 F

- Motor lock like SVA 2000, but with integrated PR module for use in fire and smoke doors (excluding permanent door release function)

## SVI passive door leaf locks

### SVI 5000

- Purely mechanical lock with emergency escape function

### SVI 4000

- Electrically monitored emergency-escape lock
- Status message for lock rod and lever handle

### SVI 2000 F

- Operation modes for the motor lock: Analogue to control unit, controlled via SVA 2000/F
- Status message for lock rod and lever handle
- Direct connection to dormakaba ED swing door drives or a SafeRoute escape route security system
- With integrated PR module for use in fire and smoke doors

## Combination matrix SVA/SVI

	SVI 5000	SVI 4000	SVI 2000 F
SVA 5000	●	○	-
SVA 4000	●	●	-
SVA 6000	●	●	-
SVA 2000	●	●	●
SVA 2000 F	●	●	●

● Compatible ○ Optional – Not possible

## F Certificate of suitability

The SVP/SVI locks with automatic locking action have been approved and quality-tested by the notified body MPA in Dortmund.  
An approval or verification of suitability in conjunction with the respective fire and smoke door may be required.



The SVA/SVI locks in combination with lever handles and panic bars from various manufacturers have been certified according to EN 179 "Emergency exit devices operated by a lever handle or push pad for escape route doors" and EN 1125 "Panic exit devices operated by a horizontal bar", and therefore carry the CE mark of conformity CE.

### Features and functions SVA/SVI lock combinations with automatic locking action for double-leaf doors

		SVA active door leaf					SVI passive door leaf		
		SVA 5000	SVA 4000	SVA 6000	SVA 2000	SVA 2000 F	SVI 5000	SVI 4000	SVI 2000 F
<b>Approvals</b>	Fire and smoke doors	●	●	●	● <sup>2)</sup>	●	●	●	●
	DIN EN 179/DIN EN 1125	●	●	●	●	●	●	●	●
<b>Emergency escape functions</b>	Door opening from inside via lever handle/pushbar	●	●	●	●	●	●	●	●
	Forced closure function (C)	-	-	●	-	-	-	-	-
	Panic function (E) with knob/lever set	●	●	-	●	●	-	-	-
<b>Unlock</b>	From outside with key	●	●	●	●	●	-	-	-
	From outside via lever handle after electrical release (integration in access control systems)	-	-	●	-	-	-	-	-
	- Automatic reset of the release when the door fails to open	-	-	●	●	●	-	-	●
	- Adjustable unlock or relock time	-	-	-	●	●	-	-	-
	- Permanent door release <sup>3)</sup>	-	-	-	●	● <sup>5)</sup>	-	-	● <sup>4)</sup>
	Permanent access possible <sup>1)</sup>	-	-	●	-	-	-	-	-
	Motor lock (suitable for automatic doors)	-	-	-	●	●	-	-	●
	Automatic switching off of permanent open/permanent door release if there is a power failure	-	-	●	○ <sup>3)</sup>	○ <sup>3) 5)</sup>	-	-	-
Suitable for electronic cylinders	●	●	●	●	●	-	-	-	
<b>Surveillance</b>	Message "Door open/closed"	-	●	●	●	●	-	-	-
	Message "Door locked/unlocked"	-	●	●	●	●	-	●	●
	Message "Lever handle operation/emergency escape function"	-	●	●	●	●	-	●	●
	Message "Cylinder locking"	-	●	●	●	●	-	-	-
	Message "Drive dead bolt"	-	-	-	-	-	-	●	●
	Sabotage line	-	●	●	●	●	-	-	-
	DCW®/CAN bus interface	-	-	-	●	●	-	-	●
<b>Break-in protection</b>	Insurance compliant locking (dual-point locking device)	●	●	●	●	●	●	●	●
	Mechanical self-locking	●	●	●	●	●	●	●	●
<b>Mode of operation</b>	Mechanical (without wiring)	●	-	-	-	-	●	-	-
	Mechanical with electrical monitoring	-	●	●	-	-	-	●	-
	Motorized unlocking	-	-	-	●	●	-	-	●
	Outside and inside lever handle simultaneously electric engageable / disengageable	-	-	●	-	-	-	-	-
<b>Miscellaneous</b>	Mechanical process control	●	●	●	●	●	●	●	●
	Electronic sequential control	-	-	-	●	●	-	-	●

● Yes – No ○ Optional

<sup>1)</sup> PERMANENT OPEN function also permissible on fire and smoke doors, as the doors have a tumbler in case of a fire.

<sup>2)</sup> For fire and smoke doors in conjunction with the PR module (emergency power buffer).

<sup>3)</sup> In fire and smoke doors not approved for permanent door release, as approval is not guaranteed in the event of a fire.

<sup>4)</sup> Depending on the SVA lock used on the active leaf.

<sup>5)</sup> Only in combination with ED 100/250, SVP S3x /4x or SafeRoute.

# Components of an SVA/SVI locking system

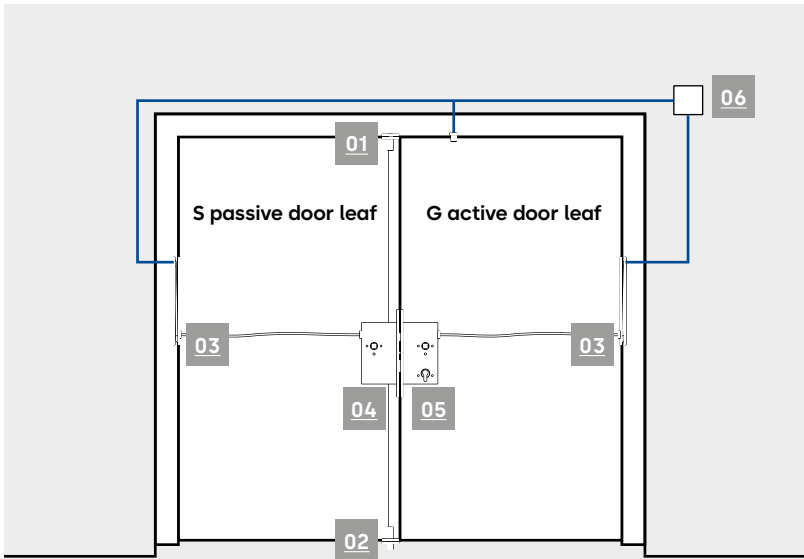

**01** Bar strike plate for door frame and switch lock for top drive dead bolt

**02** Shoot bolt guide and ground keeper

**03** SVP-A connection cable and cable loop from door leaf to door frame when using electrical emergency-escape locks

**04** SVI emergency-escape lock for the passive door leaf with bottom and top drive dead bolt  
The SVI passive door leaf lock serves as a strike box for an SVA emergency-escape lock.

SVI passive door leaf lock available in different variants for steel frame and timber doors.

**05** SVA emergency-escape lock for the active door leaf is available in different variants for narrow stile and timber doors.

**06** Optional: Motor lock control unit only necessary for SVA 2xxx or SVA 2xxx F when the control of the emergency-escape lock does not take place directly via the data bus to the TMS, SafeRoute or automatic actuator ED 100/250. See "Accessories" chapter.

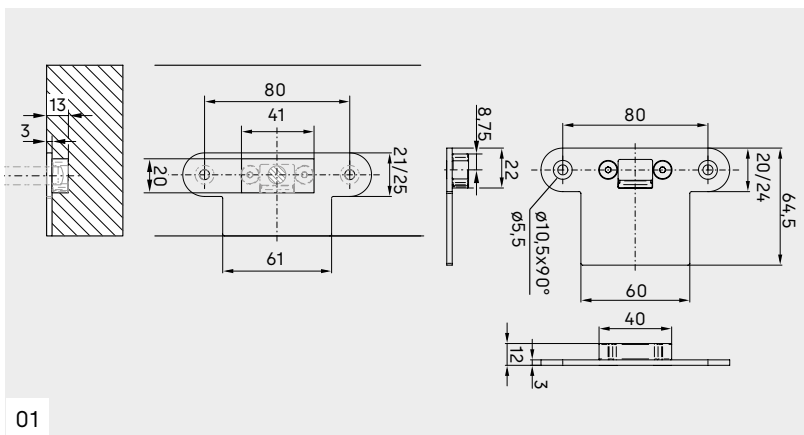
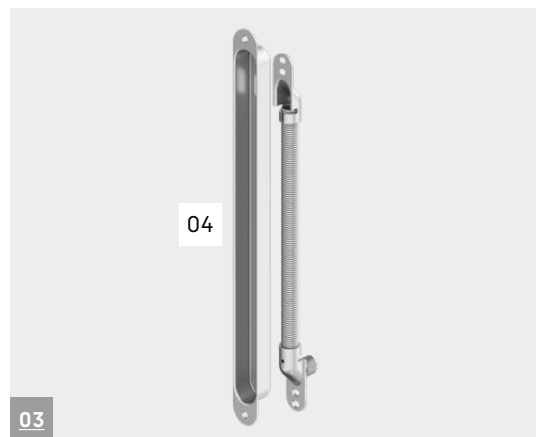
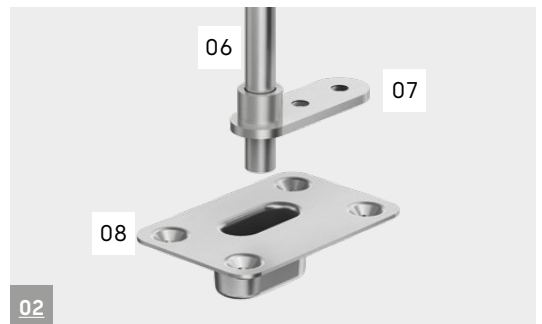
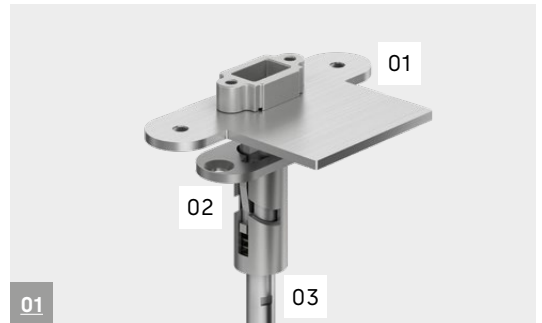

01

### 01 Bar strike plate

For mounting on the door frame for holding the drive dead bolt in the passive door leaf.

### 02 Switch lock

For installation on the passive door leaf.

### 03 Top drive dead bolt

Locking element of the SVI xxxx passive door leaf lock.

### 04 Cable loop

dormakaba offers various solutions for the transition of the connection cable from the door leaf to the door frame. The cable loop is not required for the SVA 5xxx and SVI 5xxx. See "Accessories" chapter.

### 05 SVP A connection cable (not shown)

The connection cable for connecting electrical emergency-escape locks. The connection cable is not required for the SVA 5xxx and SVI 5xxx. See "Accessories" chapter.

### 06 Bottom drive dead bolt

### 07 Shoot bolt guide

For installation on the passive door leaf.

### 08 Ground keeper

Simple ground keeper for holding the bottom drive dead bolt.

### 09 Adjustable ground keeper

Alternative to simple ground keeper for receiving the bottom drive dead bolt.

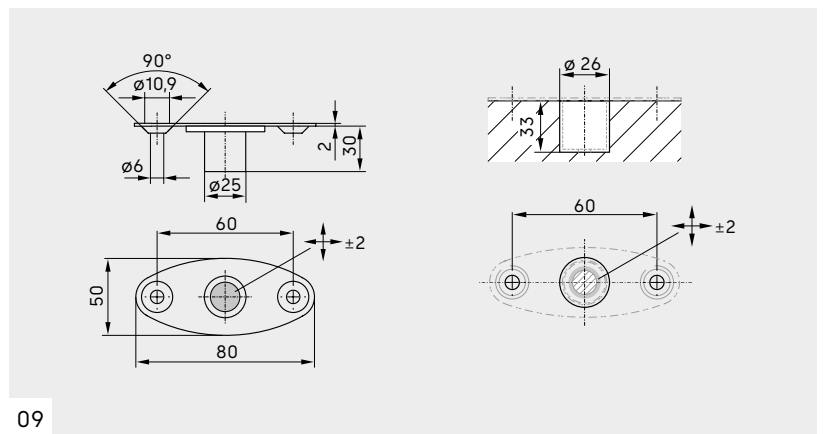
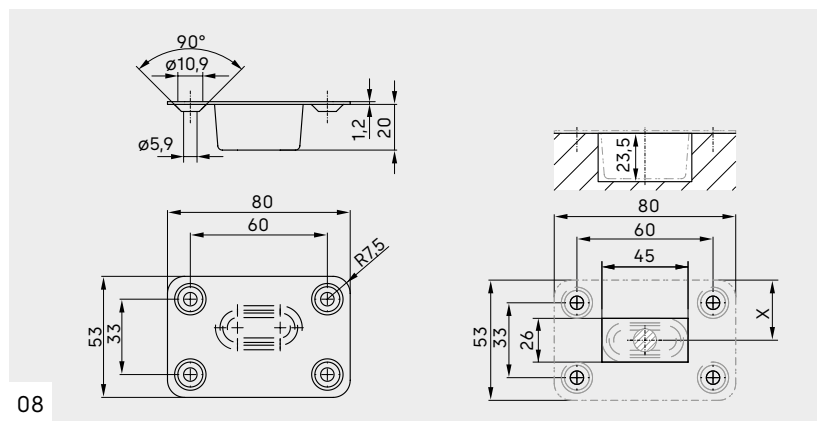
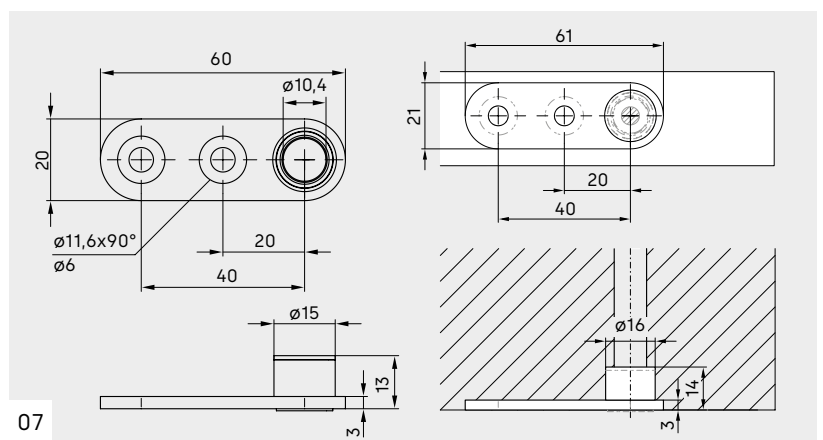
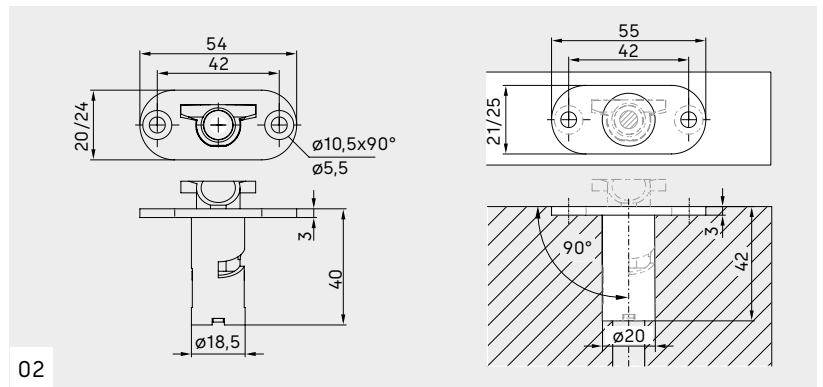



# Dimensions and sections SVA 2xxx/SVA 4xxx/SVA 5xxx/SVA 6xxx for narrow stile doors

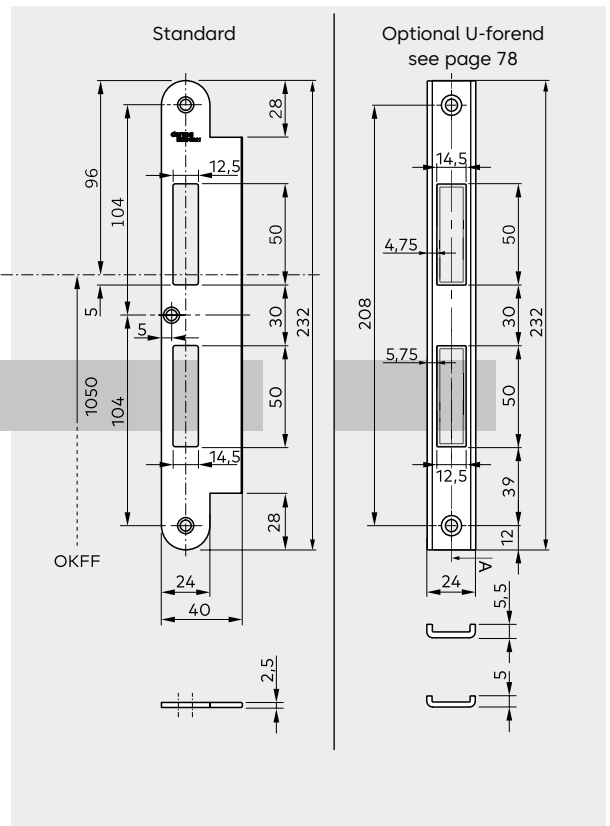
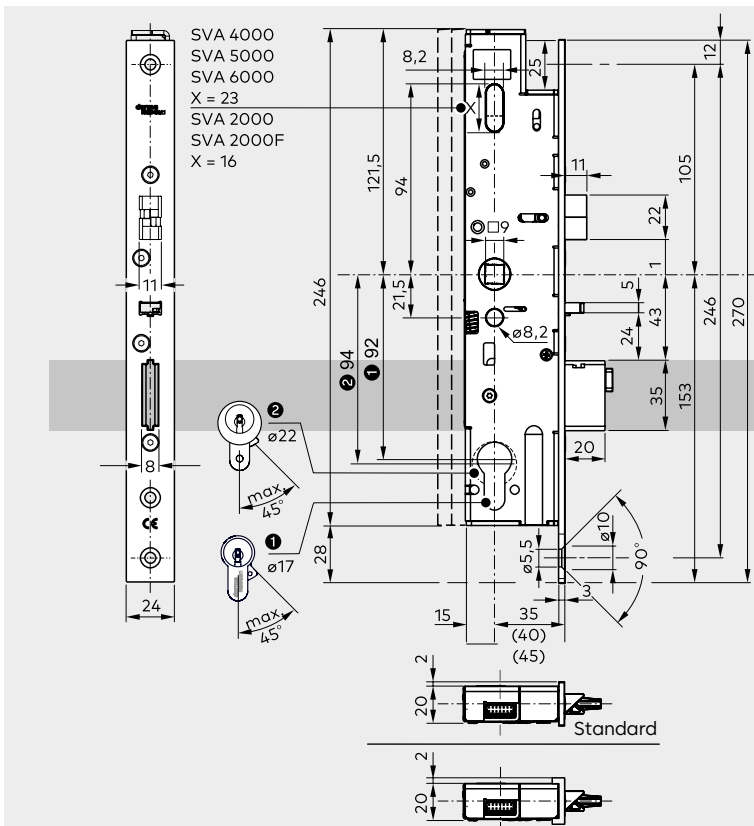

Deburr the edges.  
Remove swarf  
from the cut-out.

Optional U-forend  
see page 78

Deburr the edges.  
Remove swarf  
from the cut-out.

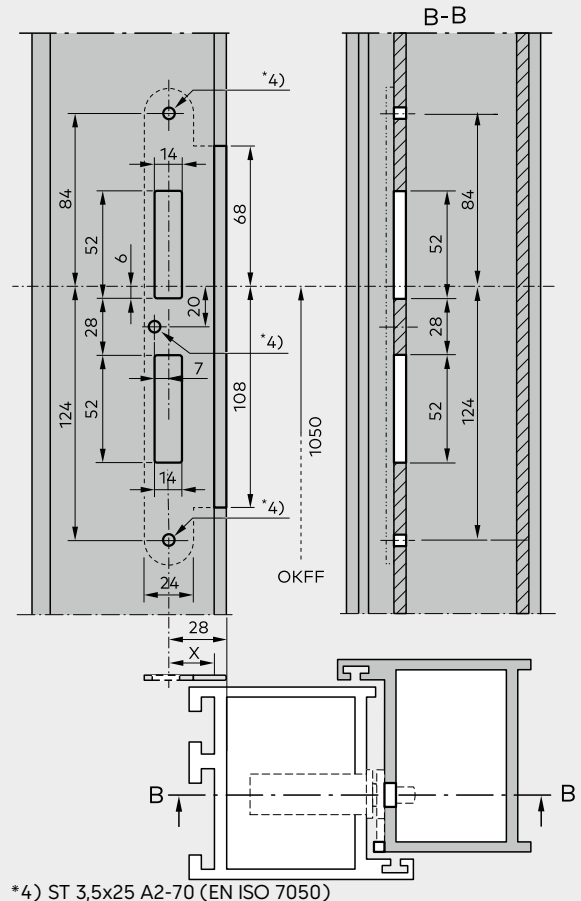
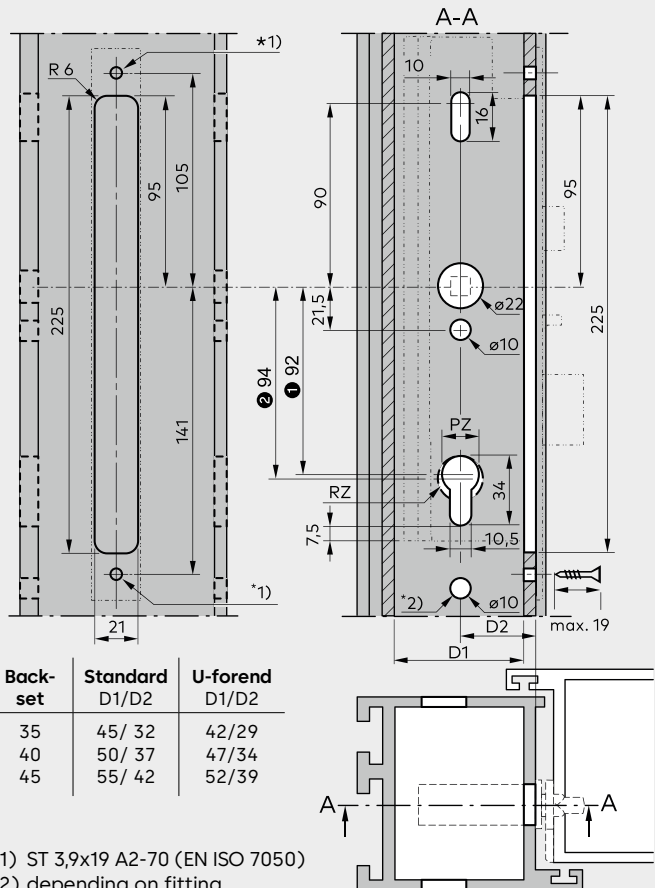

\*1) ST 3,9x19 A2-70 (EN ISO 7050)  
\*2) depending on fitting

\*4) ST 3,5x25 A2-70 (EN ISO 7050)

## Dimensions and sections SVI 2xxx F/SVI 4xxx/SVI 5xxx for timber doors

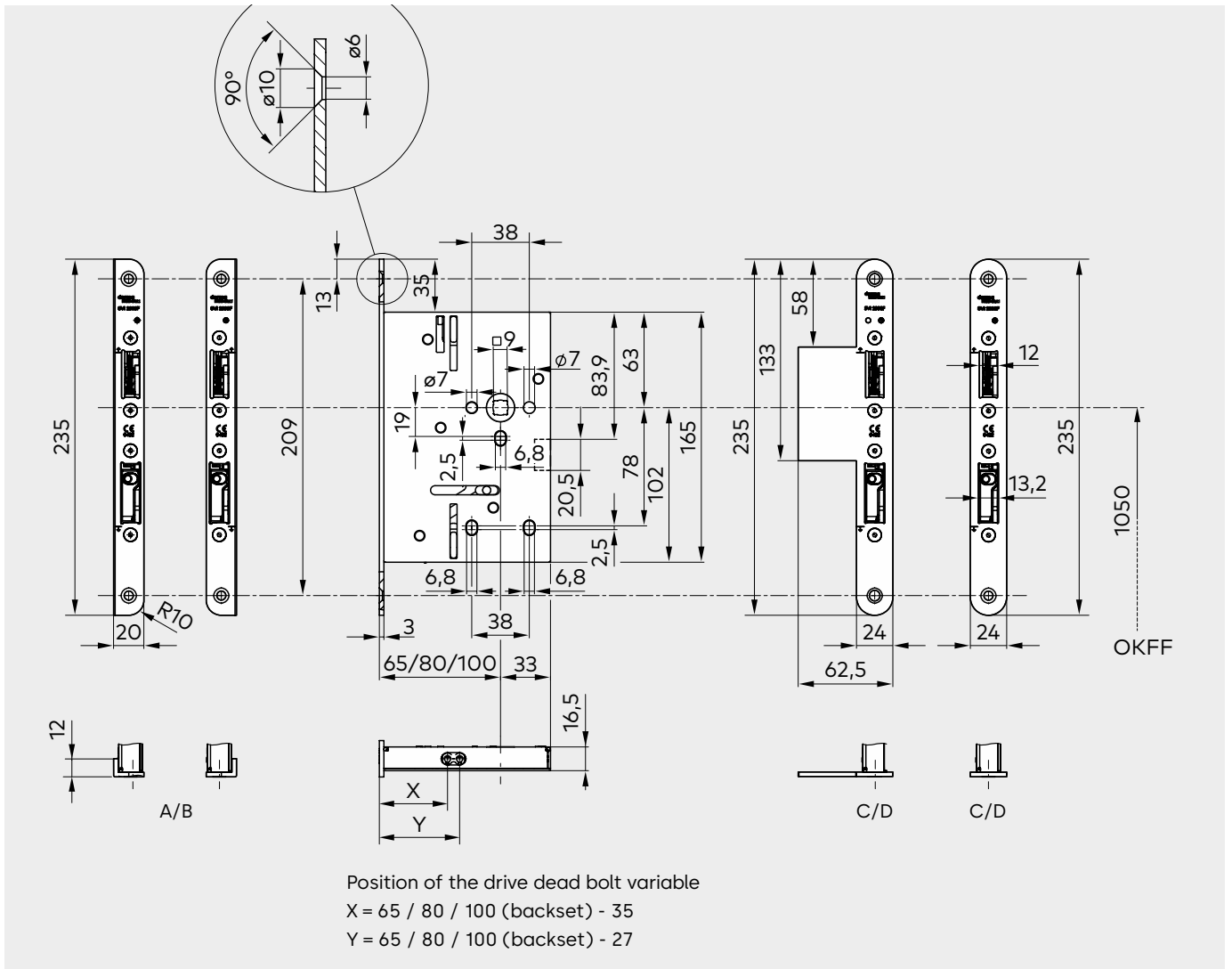

### Sections version with lug faceplate

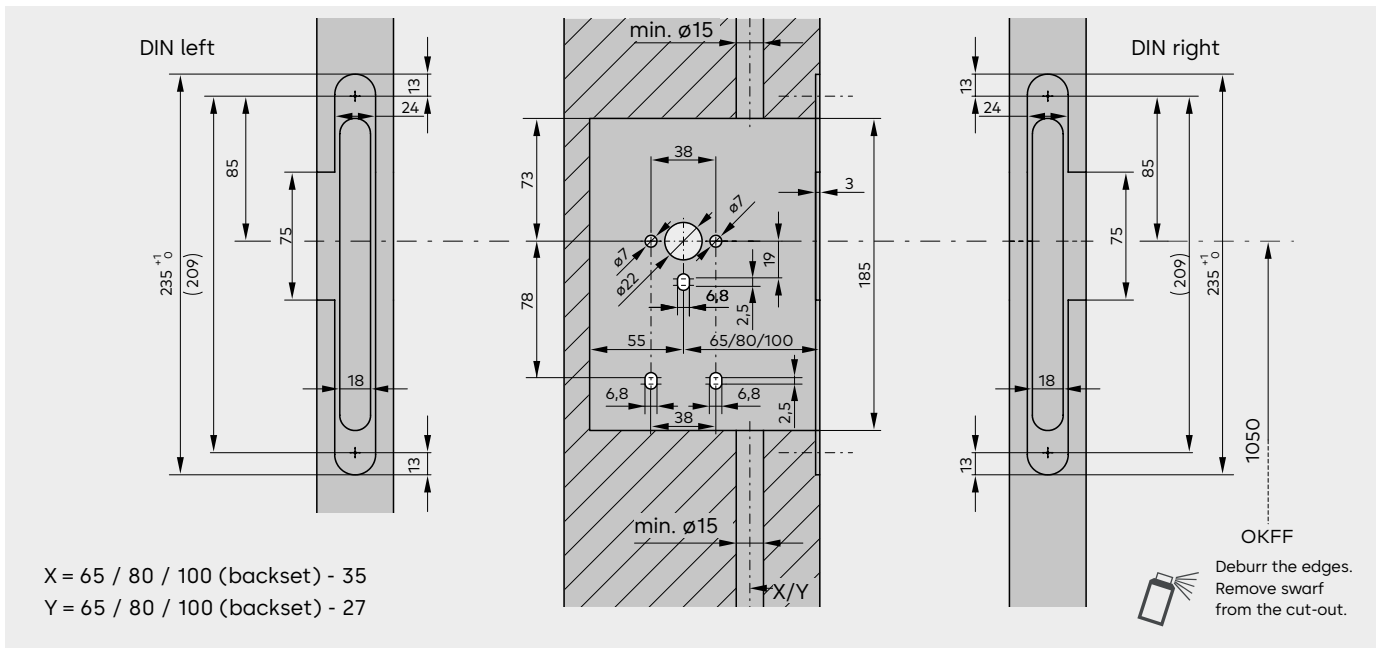



## Dimensions and sections SVI 2xxx F for narrow stile doors

Standard

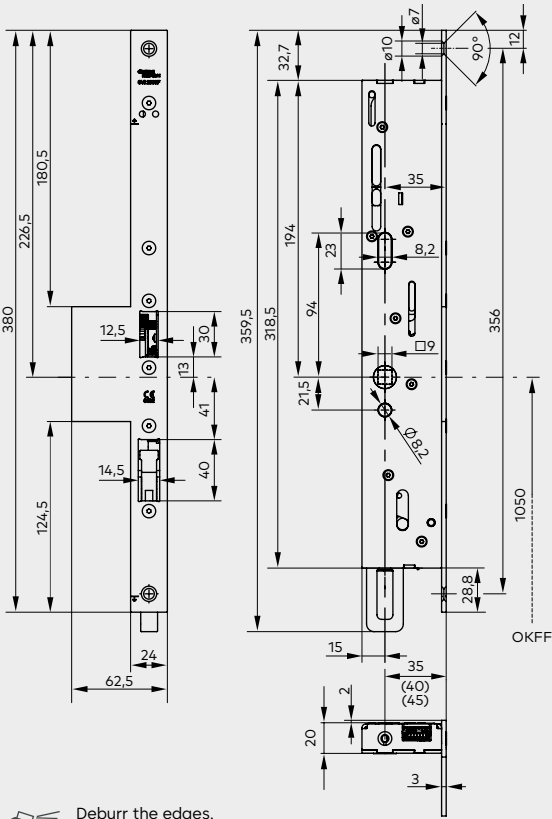

Deburr the edges.  
Remove swarf  
from the cut-out.

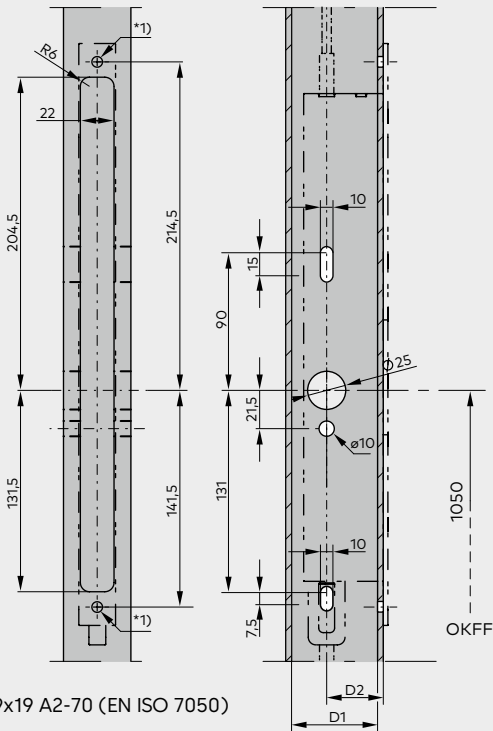

\*1) ST 3,9x19 A2-70 (EN ISO 7050)

Back-set	Standard D1/D2
35	45/ 32
40	50/ 37
45	55/ 42

Optional U-forend see page 78

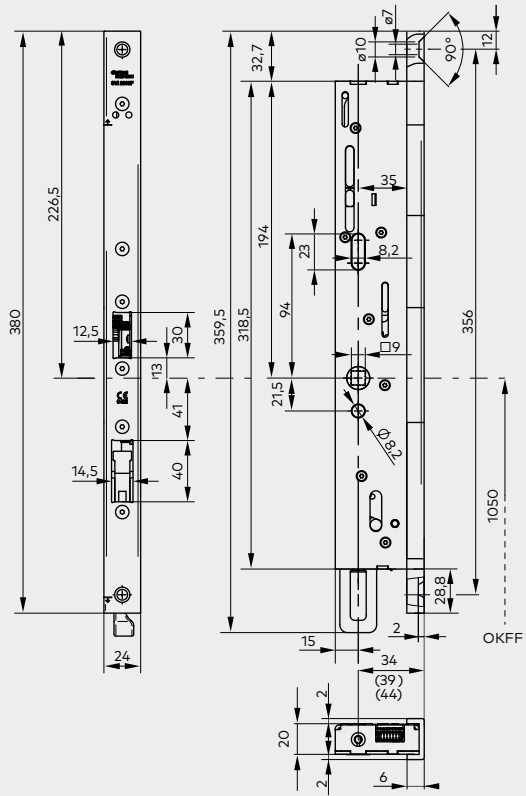

Deburr the edges.  
Remove swarf  
from the cut-out.

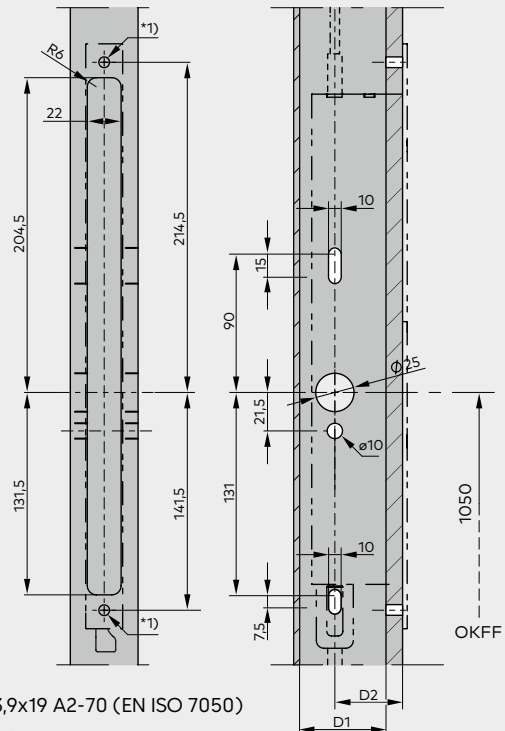



\*1) ST 3,9x19 A2-70 (EN ISO 7050)

Back-set	U-forend D1/D2
34	42/29
39	47/34
44	52/39

# Dimensions and sections SVI 4xxx/SVI 5xxx for narrow stile doors

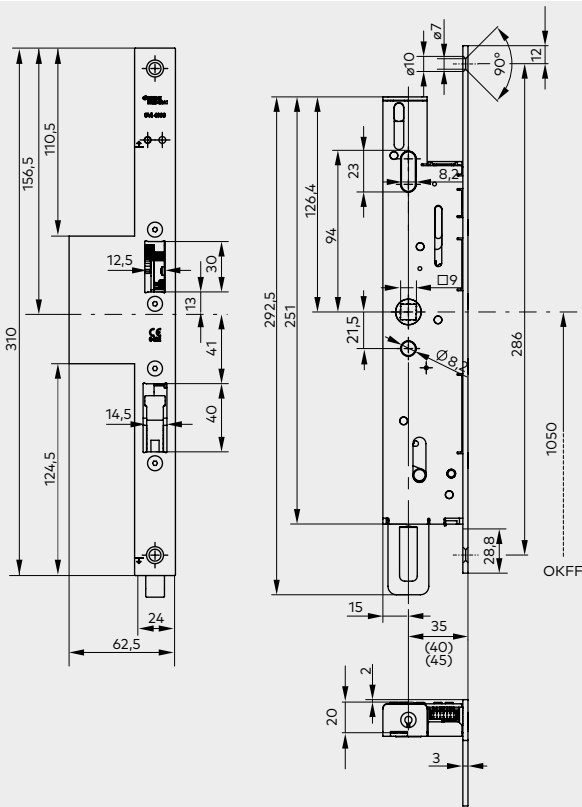
Standard



 Deburr the edges.  
Remove swarf  
from the cut-out.

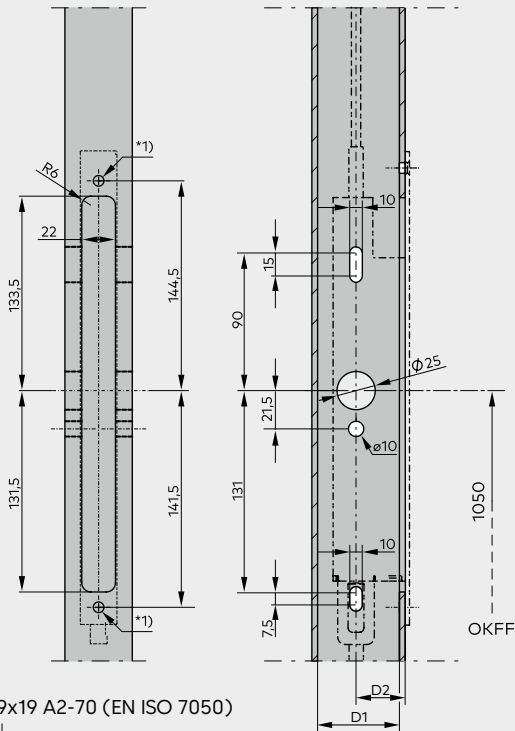

\*1) ST 3,9x19 A2-70 (EN ISO 7050)

Back-set	Standard D1/D2
35	45/ 32
40	50/ 37
45	55/ 42

Optional U-forend see page 78

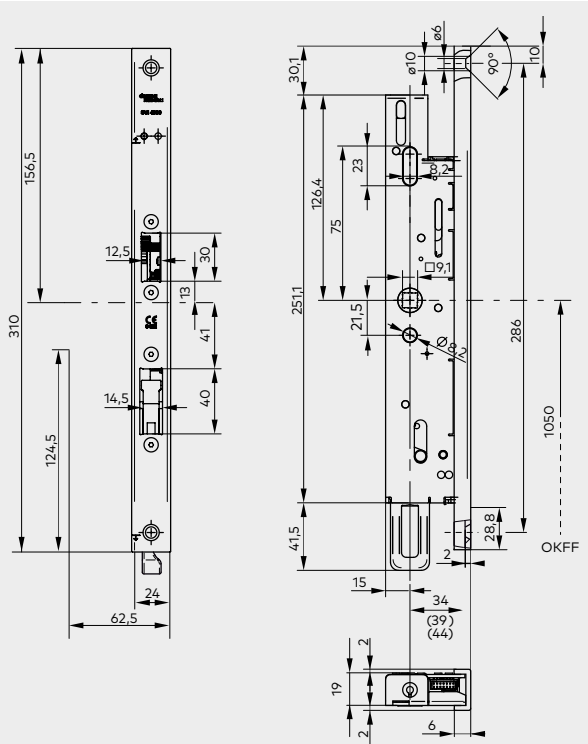

 Deburr the edges.  
Remove swarf  
from the cut-out.

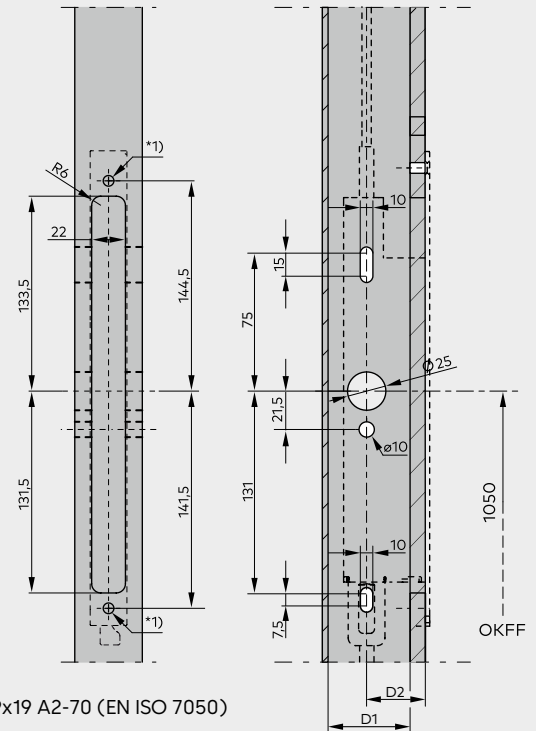

\*1) ST 3,9x19 A2-70 (EN ISO 7050)

Back-set	U-forend D1/D2
34	42/29
39	47/34
44	52/39

## SVA 5000 – Emergency-escape lock with automatic locking action

### SVA 5xxx

Active emergency-escape lock with automatic locking mechanism for the active door leaf in double-leaf door systems with optimised mechanical sequential control. Duisburg function: compatible with all kinds of cylinders, even electronic and free wheel cam cylinders. Two-point locking activated by pre-loaded spring when door closes. Universal trip latch (270 x 24 mm faceplate versions can be used for DIN left and right). Emergency unlocking using the lever handle or panic bar according to EN 179, EN 1125 and EN 12209. Panic function for unlocking from the outside using a key. Steel bolt with 20 mm projection, 9 mm square-section follower. Corrosion-protected lock case to DIN dimensions, complete with faceplate and strike plate in stainless steel included in delivery.

### Installation

- Timber rebated door
- Timber non-rebated door
- Narrow stile door
- DIN left
- DIN right

### perforation

- Profile cylinder PC
- Round cylinder RC

**B** Backset \_\_\_\_\_ mm

Required accessories (to be ordered separately):

- SVI 5xxx or SVI 4xxx

### Other accessories

see Page 76

### Dimensions and installation drawings

see Page 38

### SVA 5xxx locking system on active door leaf

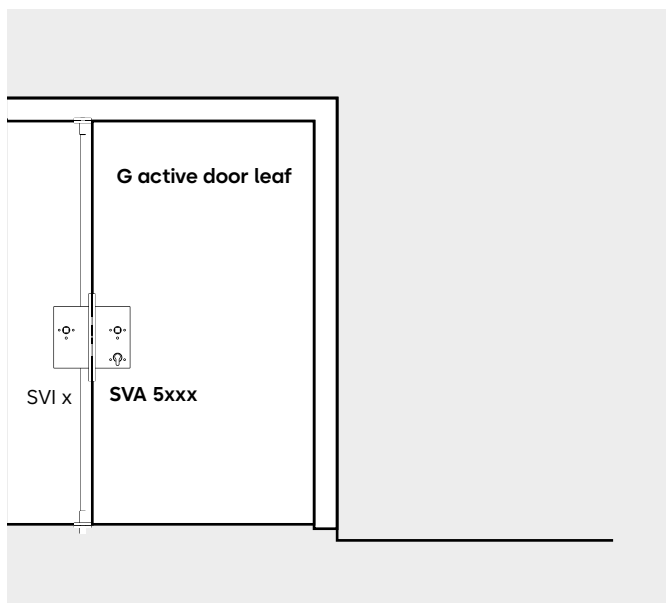

**SVA 5xxx  
for timber doors  
(active door leaf)**

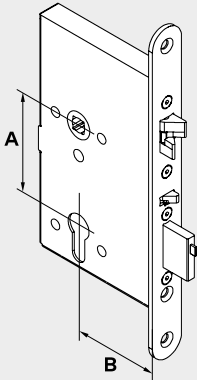

Lock cylinder	Door type	Backset B	DIN	Type	Article no.
PC (A = 72)	Rebated door Forend: 235 x 20	65	Left	SVA 5271	70010016
			Right	SVA 5272	70010017
		80	Left	SVA 5281	70010018
			Right	SVA 5282	70010019
		100	Left	SVA 5291	70010020
			Right	SVA 5292	70010021
	Non-rebated door Forend: 235 x 24	65	L/R	SVA 5277	70010024
		80	L/R	SVA 5287	70010025
		100	L/R	SVA 5297	70010026
	RC (A = 74)	Rebated door Forend: 235 x 20	65	Left	SVA 5371
Right				SVA 5372	70010007
80			Left	SVA 5381	70010318
			Right	SVA 5382	70010319
100			Left	SVA 5391	70010320
			Right	SVA 5392	70010321
Non-rebated door Forend: 235 x 24		65	L/R	SVA 5377	70010009
		80	L/R	SVA 5387	70010010
		100	L/R	SVA 5397	70010011

All dimension data in millimetres (mm)  
**PC** Profile cylinder **RC** Round cylinder **L** DIN left **R** DIN right

**SVA 5xxx  
for metal-framed doors  
(active door leaf)**

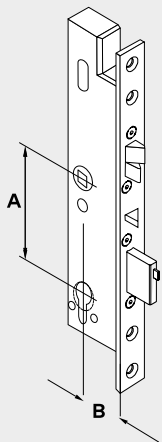

Lock cylinder	Door type	Backset B	DIN	Type	Article no.
PC (A = 92)	Narrow stile door Forend: 270 x 24	35	L/R	SVA 5719	70010030
		40	L/R	SVA 5729	70010031
		45	L/R	SVA 5739	70010032
RC (A = 94)	Narrow stile door Forend: 270 x 24	35	L/R	SVA 5819	70010027
		40	L/R	SVA 5829	70010028
		45	L/R	SVA 5839	70010029

All dimension data in millimetres (mm)  
**PC** Profile cylinder **RC** Round cylinder **L** DIN left **R** DIN right

## SVA 4000 – Emergency-escape lock with automatic locking action and electrical status monitoring

SVA 4xxx 

Emergency-escape lock with automatic locking action for double-leaf door systems, electric monitoring and optimised mechanical sequential control. With status monitoring for detecting "locked" (> 90%), "unlocked" (< 10% of the latch bolt path), "door open/closed" (via trigger) as well as "handle operation/emergency unlocking" and "cylinder contact". Two-point locking activated by pre-loaded spring when door closes. Non-handed trigger (24 mm forend versions can be used DIN L/R). Emergency unlocking by lever handle, change to unlocking function with key access from the outside. Steel bolt, projection 20 mm. 9 mm square-section follower Corrosion-protected lock case in DIN dimensions, complete with forend and strike plate in stainless steel, included in delivery. Certified in accordance with EN 179 and EN 1125 for use with panic door fittings.

Maximum load current 100 mA at max. 30 V DC

Status messages via potential-free contacts

### Installation

- Timber rebated door
- Timber non-rebated door
- Narrow stile door
- DIN left  DIN right

perforation

- Profile cylinder PC
- Round cylinder RC

**B** Backset \_\_\_\_\_ mm

Required accessories (to be ordered separately):

- SVI 5xxx or SVI 4xxx
- dormakaba SVP-A connection cable
- dormakaba cable loop/spiral cable

### Other accessories

see Page 76

### Dimensions and installation drawings

see Page 38

### SVA 4xxx locking system on active door leaf

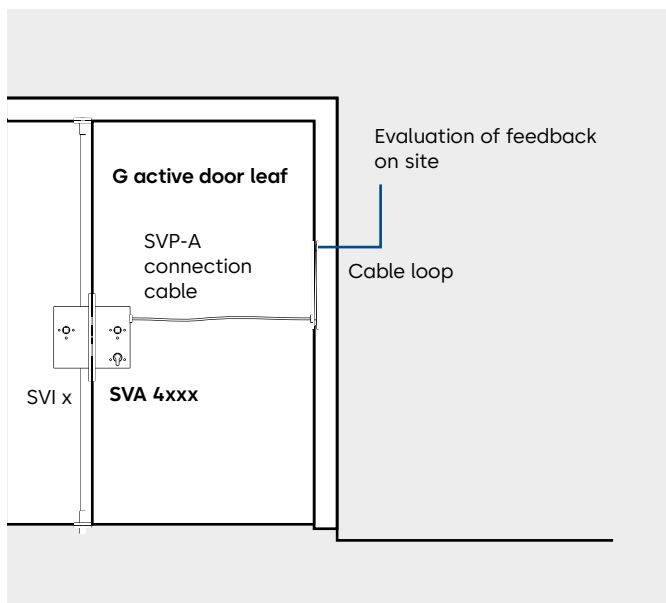

### Wiring layout

#### Cable colours SVA 4xxx function

Black	GND
Brown	"Trigger engaged", NC
pink/grey	"SVP unlocked", NO
Red	free
White	free
Yellow	"SVP unlocked" and "Trigger engaged" and cylinder actuated/lock open, C
Green	Cylinder actuated, NO
Grey	Sabotage line
Pink	Sabotage line
red/blue	"SVP locked", NC
Blue	"Handle operated", NO
Violet	"SVP locked" and "Handle operated", C

Evaluation of feedback on site

(for example, in conjunction with dormakaba SafeRoute)

**SVA 4xxx  
for timber doors  
(active door leaf)**

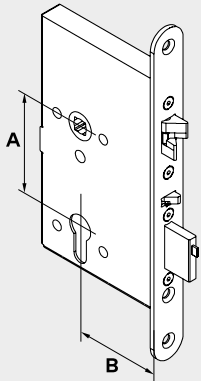

Lock cylinder	Door type	Backset B	DIN	Type	Article no.
PC (A = 72)	Rebated door Forend: 235 x 20	65	Left	SVA 4271	70010048
			Right	SVA 4272	70010049
		80	Left	SVA 4281	70010050
			Right	SVA 4282	70010051
		100	Left	SVA 4291	70010052
			Right	SVA 4292	70010053
RC (A = 74)	Non-rebated door Forend: 235 x 24	65	L/R	SVA 4277	70010056
			80	L/R	SVA 4287
		100	L/R	SVA 4297	70010058
			65	Left	SVA 4371
		Right		SVA 4372	70010039
		80		Left	SVA 4381
Right	SVA 4382	70010315			
100	Left	SVA 4391	70010316		
	Right	SVA 4392	70010317		
	65	L/R	SVA 4377	70010041	
		80	L/R	SVA 4387	70010042
	100	L/R	SVA 4397	70010043	

All dimension data in millimetres (mm)  
**PC** Profile cylinder **RC** Round cylinder **L** DIN left **R** DIN right

**SVA 4xxx  
for metal-framed doors  
(active door leaf)**

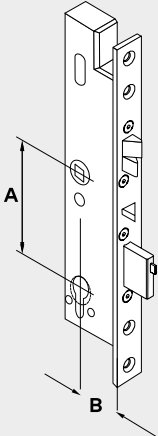

Lock cylinder	Door type	Backset B	DIN	Type	Article no.
PC (A = 92)	Narrow stile door Forend: 270 x 24	35	L/R	SVA 4719	70010062
		40	L/R	SVA 4729	70010063
		45	L/R	SVA 4739	70010064
RC (A = 94)	Narrow stile door Forend: 270 x 24	35	L/R	SVA 4819	70010059
		40	L/R	SVA 4829	70010060
		45	L/R	SVA 4839	70010061

All dimension data in millimetres (mm)  
**PC** Profile cylinder **RC** Round cylinder **L** DIN left **R** DIN right

## SVA 6000 – Microswitch-monitored emergency-escape lock with automatic locking action

SVA 6xxx 

Microswitch-monitored emergency-escape lock with automatic locking action for double-leaf door systems, versions for narrow stile (67xx/68xx) or timber doors (62xx/63xx), electrically monitored, with split follower, electrically-activated outside lever handle and optimised mechanical sequential control. With status monitoring for detecting "Locked" (> 90%), "Unlocked" (< 10% of the latch bolt path), "door open/closed" (via trip latch) as well as "Lever handle operation/emergency unlocking" and "Cylinder contact". When there is no power, the outside handles are disengaged (operating current) or engaged (closed-circuit current). The outside handle is engaged or disengaged by activating the solenoid (for example, via the access control system). The lever handle is always engaged in the direction of escape. Activation of the outside handle is effected via a GND contact by means of a potential-free NO (operating current) or NC (closed-circuit current). Permanently open mode possible (permanent engagement of outside handle, e.g. for daytime mode). Two-point locking activated by pre-loaded spring when door closes. Non-handed trigger (24 mm forend versions can be used DIN L/R). Unlocking from the outside using key or engaged outside handle. Steel bolt, projection 20 mm. Split 9 mm square-section follower. Corrosion-protected lock case in DIN dimensions, complete with forend and strike plate in stainless steel, included in delivery.

Supply voltage	12 or 24 V DC stabilised (+/- 15%)
Power input	0.15 A (max. 0.3 A)
Maximum load current	100 mA at max. 30 V DC
Status messages via potential-free contacts	

### Installation

- Timber rebated door
- Timber non-rebated door
- Narrow stile door
- DIN left  DIN right
- Escape route opening outwards (normal case)
- Escape route opening inwards (special case)

### perforation

- Profile cylinder PC
- Round cylinder RC
- B** Backset \_\_\_\_\_ mm

- Closed-circuit current (only with narrow stile door, timber door variant is adjustable)
- Operating current (only with the narrow stile door, timber door variant is adjustable)

### Required accessories (to be ordered separately):

- SVI 5xxx or SVI 4xxx
- dormakaba SVP-A connection cable
- dormakaba cable loop/spiral cable
- dormakaba NT power supply unit

### Other accessories

see Page 76

### Dimensions and installation drawings

see Page 38

### SVA 6xxx locking system on active door leaf

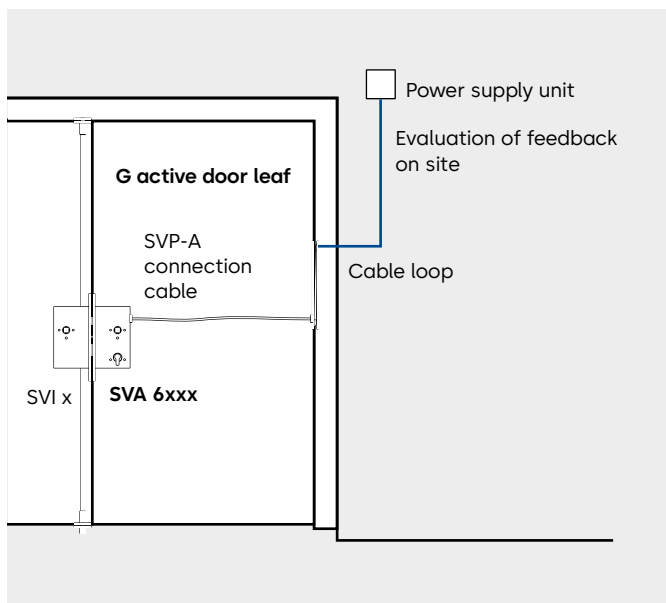





### Wiring layout

#### Cable colours SVZ 6xxx function

Black	GND
Brown	"Trigger engaged", NC
pink/grey	"SVP unlocked", NO
Red	Lever handle engaged via GND contact Operating current = NO/Closed-circuit current = NC
White	+12 V DC or +24 V DC (stabilised)
Yellow	"SVP unlocked" and "Trip latch engaged" and cylinder actuated, C
Green	Cylinder actuated, NO
Grey	Sabotage line
Pink	Sabotage line
red/blue	"SVP locked", NC
Blue	"Handle operated", NO
Violet	"SVP locked" and "Handle operated", C

Evaluation of feedback on site  
(for example, in conjunction with dormakaba SafeRoute)

Door may always be opened in the direction of escape

-  Direction of escape
-  Lever handle permanently engaged
-  Electrically activated lever handle
-  Hinge L/R

Opening outwards (normal case)

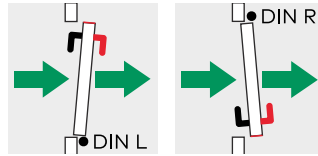

Opening inwards (special case)

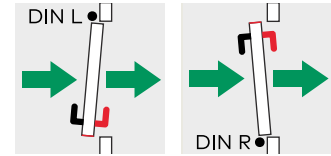

**SVA 6xxx  
for timber doors  
(active door leaf)**

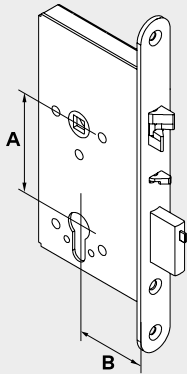

Lock cylinder	Door type	Backset B	DIN	Type	Article no.
PC (A = 72)	Rebated door Forend: 235 x 20	65	L-outwards/R-inwards	SVA 6271	70010099
			R-outwards/L-inwards	SVA 6272	70010100
		80	L-inwards/R-outwards	SVA 6273	70010101
			R-inwards/L-outwards	SVA 6274	70010102
		100	L-outwards/R-inwards	SVA 6281	70010105
			R-outwards/L-inwards	SVA 6282	70010106
	Non-rebated door Forend: 235 x 24	65	L-inwards/R-outwards	SVA 6283	70010107
			R-inwards/L-outwards	SVA 6284	70010108
		80	L-outwards/R-inwards	SVA 6291	70010111
			R-outwards/L-inwards	SVA 6292	70010112
		100	L-inwards/R-outwards	SVA 6293	70010113
			R-inwards/L-outwards	SVA 6294	70010114
RC (A = 74)	Rebated door Forend: 235 x 20	65	L-outwards/R-inwards	SVA 6277	70010103
			R-outwards/L-inwards	SVA 6278	70010104
		80	L-outwards/R-inwards	SVA 6288	70010109
			R-outwards/L-inwards	SVA 6277	70010110
		100	L-outwards/R-inwards	SVA 6297	70010115
			R-outwards/L-inwards	SVA 6298	70010116
	Non-rebated door Forend: 235 x 24	65	L-outwards/R-inwards	SVA 6371	70010077
			R-outwards/L-inwards	SVA 6372	70010078
		80	L-inwards/R-outwards	SVA 6373	70010079
			R-inwards/L-outwards	SVA 6374	70010080
		100	L-outwards/R-inwards	SVA 6381	70010322
			R-outwards/L-inwards	SVA 6382	70010323
	Non-rebated door Forend: 235 x 24	65	L-inwards/R-outwards	SVA 6383	70010324
			R-inwards/L-outwards	SVA 6384	70010325
		80	L-outwards/R-inwards	SVA 6391	70010326
			R-outwards/L-inwards	SVA 6392	70010327
		100	L-inwards/R-outwards	SVA 6393	70010328
			R-inwards/L-outwards	SVA 6394	70010329
Non-rebated door Forend: 235 x 24	65	L-outwards/R-inwards	SVA 6377	70010081	
		R-outwards/L-inwards	SVA 6378	70010082	
	80	L-outwards/R-inwards	SVA 6387	70010083	
		R-outwards/L-inwards	SVA 6388	70010084	
	100	L-outwards/R-inwards	SVA 6397	70010085	
		R-outwards/L-inwards	SVA 6398	70010086	

All dimension data in millimetres (mm) PC Profile cylinder RC Profile round cylinder L DIN-L R DIN-R

**SVA 6xxx  
for narrow stile doors  
(active door leaf)**

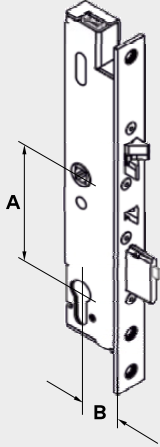

Lock cylinder	Door type	B Backset	DIN	Type	Article no.
PC (A = 92)	Narrow stile door Forend: 270 x 24 Operating current (Fail Secure)	35	R-outwards/L-inwards	SVA 6710	70010123
			L-outwards/R-inwards	SVA 6719	70010124
	40	R-outwards/L-inwards	SVA 6720	70010125	
		L-outwards/R-inwards	SVA 6729	70010126	
	45	R-outwards/L-inwards	SVA 6730	70010127	
		L-outwards/R-inwards	SVA 6739	70010128	
	Narrow stile door Forend: 270 x 24 Closed-circuit current (Fail Safe)	35	R-outwards/L-inwards	SVA 6710	70010135
			L-outwards/R-inwards	SVA 6719	70010136
		40	R-outwards/L-inwards	SVA 6720	70010137
			L-outwards/R-inwards	SVA 6729	70010138
45		R-outwards/L-inwards	SVA 6730	70010139	
		L-outwards/R-inwards	SVA 6739	70010140	
RC (A = 94)	Narrow stile door Forend: 270 x 24 Operating current (Fail Secure)	35	R-outwards/L-inwards	SVA 6810	70010117
			L-outwards/R-inwards	SVA 6819	70010118
		40	R-outwards/L-inwards	SVA 6820	70010119
			L-outwards/R-inwards	SVA 6829	70010120
	45	R-outwards/L-inwards	SVA 6830	70010121	
		L-outwards/R-inwards	SVA 6839	70010122	
	Narrow stile door Forend: 270 x 24 Closed-circuit current (Fail Safe)	35	R-outwards/L-inwards	SVA 6810	70010129
			L-outwards/R-inwards	SVA 6819	70010130
		40	R-outwards/L-inwards	SVA 6820	70010131
			L-outwards/R-inwards	SVA 6829	70010132
	45	R-outwards/L-inwards	SVA 6830	70010133	
		L-outwards/R-inwards	SVA 6839	70010134	

All dimension data in millimetres (mm) PC Profile cylinder RC Profile round cylinder L DIN-L R DIN-R



**Simply good, twice easy.**

Where ease of handling and quality are called for.

# SVA 2000 – Emergency escape motor lock with automatic locking action

## SVA 2xxx

Motorised emergency-escape lock with automatic locking action for double-leaf doors with optimised mechanical and electronic sequential control. Possible operation modes: direct by analogue actuation, with external control unit SVP-S 3x (Switzerland) and SVP-S 4x (with full functionality) or via DCW® bus or CAN bus to SafeRoute and/or ED 100/250. LED status display shows error messages, such as incorrect operating voltage or bus connection interrupted and more! With status monitoring for detecting "Locked" (> 90%), "Unlocked" (< 10% of the latch bolt path), "Door open/closed" (via trip latch) as well as "Handle operation/emergency unlocking" and "Cylinder contact". Two-point locking activated by pre-loaded spring when door closes. Universal trip latch (24 mm faceplate versions can be used LH or RH). Emergency unlocking using lever handle in accordance with EN 179 or panic bar in accordance with EN 1125 as well as a transmission function for unlocking from the outside using keys. Steel bolt 20 mm projection, 9 mm square-section follower. Corrosion-protected lock case in DIN dimensions, complete with forend and strike plate in stainless steel, included in delivery. Connection to 24 V DC.

**F** For fire and smoke doors only in conjunction with the PR module (emergency power storage).

Supply voltage	24 V DC stabilised (+/- 15%)
Power input	0.05 A (max. 0.3 A)
Bus operation	DCW® bus or CAN bus (ISO 11898-3)
"Locked" signal:	Output switches to GND, 30 mA at max. 30 V DC

## Version

- Timber rebated door (angled strike plate)
- Timber non-rebated door (lipped strike plate)
- Narrow stile door (lipped strike plate)
- DIN left  DIN right

## perforation

- Profile cylinder PC  Round cylinder RC

**B** Backset \_\_\_\_\_ mm

## Required accessories (to be ordered separately):

- SVI 5xxx, SVI 4xxx or SVI 2xxx F
- dormakaba SVP-A connection cable
- dormakaba cable loop/spiral cable
- dormakaba TK Reed door contact
- for dormakaba SVP-PR fire doors

## Control via

- dormakaba SVP-S3x (CH)/S4x DCW® Motor lock control unit
- SafeRoute
- Automatic operator ED 100/250

## Other accessories

see Page 76

## Dimensions and installation drawings

see Page 38

## SVA 2xxx locking system on active door leaf

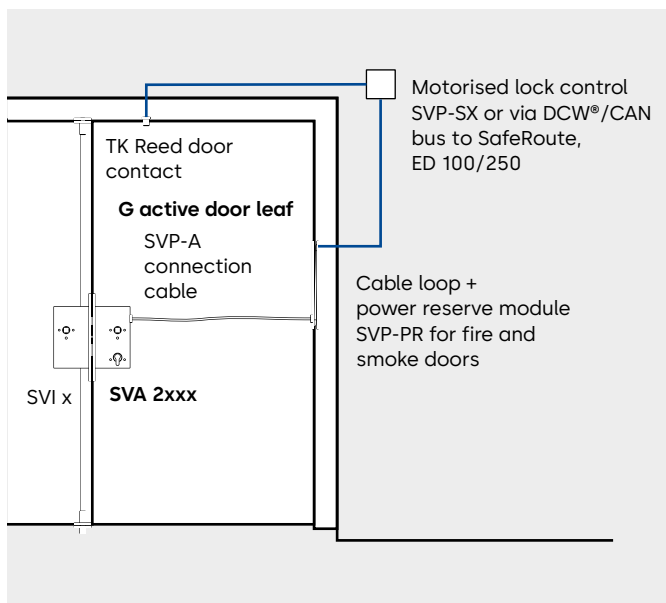

## Wiring layout

Cable colours	SVA 2xxx function		
	CAN	Stand-alone	SVP-S3x, S4x, SafeRoute or ED 100/250
Black	GND (3)	GND (3)	GND (3)
Brown	-	-	-
pink/grey	-	-	-
Red	-	Unlock SVA via GND-contact	-
White	+24 V DC (1)	+24 V DC (1)	+24 V DC (1)
Yellow	CAN L	-	A (DCW® data)
Green	CAN H	-	B (DCW® data)
Grey	-	-	-
Pink	-	-	-
red/blue	-	-	-
Blue	-	Door contact via GND contact	-
Violet	SVA locked	SVA locked 30 mA Out	SVA locked 30 mA Out

- Not assigned

**SVA 2xxx  
for timber doors  
(active door leaf)**

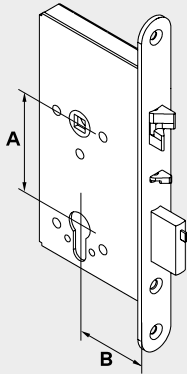

Lock cylinder	Door type	Backset B	DIN	Type	Article no.
PC (A = 72)	Rebated door Forend: 235 x 20	65	Left	SVA 2271	70010156
			Right	SVA 2272	70010157
	80	Left	SVA 2281	70010158	
		Right	SVA 2282	70010159	
	100	Left	SVA 2291	70010160	
		Right	SVA 2292	70010161	
RC (A = 74)	Rebated door Forend: 235 x 20	65	L/R	SVA 2277	70010164
		80	L/R	SVA 2287	70010165
	100	L/R	SVA 2297	70010166	
	Rebated door Forend: 235 x 20	65	Left	SVA 2371	70010146
			Right	SVA 2372	70010147
	80	Left	SVA 2381	70010306	
Right		SVA 2382	70010307		
100	Left	SVA 2391	70010308		
	Right	SVA 2392	70010309		
Non-rebated door Forend: 235 x 24	65	L/R	SVA 2377	70010149	
	80	L/R	SVA 2387	70010150	
	100	L/R	SVA 2397	70010151	

All dimension data in millimetres (mm)

PC Profile cylinder RC Round cylinder L DIN left R DIN right

**SVA 2xxx  
for narrow stile doors  
(active door leaf)**

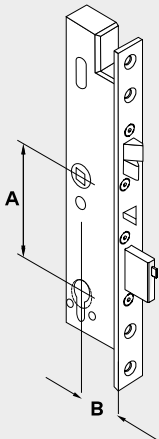

Lock cylinder	Door type	Backset B	DIN	Type	Article no.
PC (A = 92)	Narrow stile door Forend: 270 x 24	35	L/R	SVA 2719	70010170
		40	L/R	SVA 2729	70010171
		45	L/R	SVA 2739	70010172
RC (A = 94)	Narrow stile door Forend: 270 x 24	35	L/R	SVA 2819	70010167
		40	L/R	SVA 2829	70010168
		45	L/R	SVA 2839	70010169

All dimension data in millimetres (mm)

PC Profile cylinder RC Round cylinder L DIN left R DIN right

# SVA 2000 F – Emergency escape motor lock with automatic locking action and integrated power reserve module for fire and smoke doors

SVA 2xxx F 

Motorised emergency-escape lock with automatic locking action for double-leaf door systems with optimised mechanical and electronic sequential control. **Suitable for fire and smoke doors through an integrated PR module, permanent door release only in combination with ED 100/250.** Possible operation modes: direct by analogue actuation, with external control unit SVP-S 3x DCW® (Switzerland) and SVP-S 4x DCW® (stand-alone with full functionality) or via DCW® bus or CAN bus to SafeRoute and/or ED. LED status display shows error messages, such as incorrect operating voltage or bus connection interrupted and more! Duisburg function: compatible with all kinds of cylinders, even electronic and free wheel cam cylinders. With status monitoring for detecting "Locked" (> 90%), "Unlocked" (< 10% of the latch bolt path), "Door open/closed" (via trip latch) as well as "Handle operation/emergency unlocking" and "Cylinder contact". Two-point locking activated by pre-loaded spring when door closes. Universal trip latch (24 mm faceplate versions can be used LH or RH). Emergency unlocking using lever handle in accordance with EN 179 or panic bar in accordance with EN 1125, as well as a transmission function for unlocking from the outside using keys. Steel latch bolt 20 mm projection, 9 mm square-section follower. Corrosion-protected lock case in DIN dimensions, complete with forend and strike plate in stainless steel, included in delivery. Connection to 24 V.

Supply voltage	24 V DC stabilised (+/- 15%)
Power input	0.05 A (max. 0.3 A)
Bus operation	DCW® bus or CAN bus (ISO 11898-3)
"Locked" signal:	Output switches to GND, 30 mA at max. 30 V DC

## Installation

- Timber rebated door (angled strike plate)
- Timber non-rebated door (lipped strike plate)
- Narrow stile door (lipped strike plate)
- DIN left  DIN right

perforation

- Profile cylinder PC  Round cylinder RC

**B** Backset \_\_\_\_\_ mm

Required accessories (to be ordered separately):

- SVI 5xxx, SVI 4xxx or SVI 2xxx F
- dormakaba SVP-A connection cable
- dormakaba cable loop/spiral cable
- dormakaba TK Reed door contact

Control via

- dormakaba SVP-S3x (CH)/S4x DCW® Motor lock control unit
- SafeRoute
- Automatic operator ED 100/250

## Other accessories

see Page 76

## Dimensions and installation drawings

see Page 38

## SVA 2xxx F locking system on active door leaf

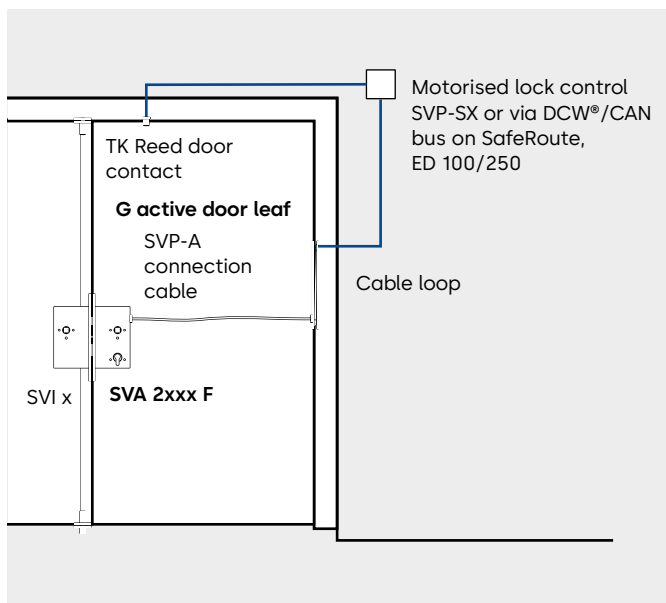

## Wiring layout

Cable colours	SVA 2xxx F function		
	CAN	Stand-alone	SVP-S3x, S4x, SafeRoute or ED 100/250
Black	GND (3)	GND (3)	GND (3)
Brown	-	-	-
pink/grey	-	-	-
Red	-	Unlock SVA via GND-contact	-
White	+24 V DC (1)	+24 V DC (1)	+24 V DC (1)
Yellow	CAN L	-	A (DCW® data)
Green	CAN H	-	B (DCW® data)
Grey	-	-	-
Pink	-	-	-
red/blue	-	-	-
Blue	-	Door contact via GND contact	-
Violet	SVA locked	SVA locked 30 mA Out	SVA locked 30 mA Out

- Not assigned

**SVA 2xxx F  
for timber doors  
(active door leaf)**

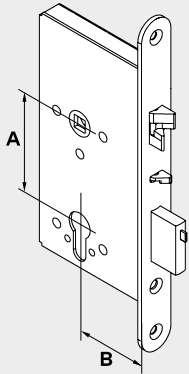

Lock cylinder	Door type	Backset B	DIN	Type	Article no.
PC (A = 72)	Rebated door Forend: 235 x 20	65	Left	SVA 2271 F	70010188
			Right	SVA 2272 F	70010189
		80	Left	SVA 2281 F	70010190
			Right	SVA 2282 F	70010191
		100	Left	SVA 2291 F	70010192
			Right	SVA 2292 F	70010193
RC (A = 74)	Non-rebated door Forend: 235 x 24	65	L/R	SVA 2277 F	70010196
		80	L/R	SVA 2287 F	70010197
		100	L/R	SVA 2297 F	70010198
RC (A = 74)	Rebated door Forend: 235 x 20	65	Left	SVA 2371 F	70010178
			Right	SVA 2372 F	70010179
		80	Left	SVA 2381 F	70010310
			Right	SVA 2382 F	70010311
		100	Left	SVA 2391 F	70010312
			Right	SVA 2392 F	70010313
RC (A = 74)	Non-rebated door Forend: 235 x 24	65	L/R	SVA 2377 F	70010181
		80	L/R	SVA 2387 F	70010182
		100	L/R	SVA 2397 F	70010183

All dimension data in millimetres (mm)  
**PC** Profile cylinder **RC** Round cylinder **L** DIN left **R** DIN right

**SVA 2xxx F  
for narrow stile doors  
(active door leaf)**

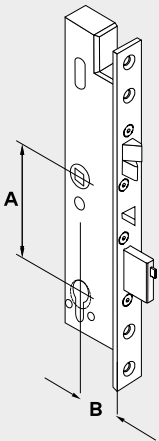

Lock cylinder	Door type	Backset B	DIN	Type	Article no.
PC (A = 92)	Narrow stile door Forend: 270 x 24	35	L/R	SVA 2719 F	70010202
		40	L/R	SVA 2729 F	70010203
		45	L/R	SVA 2739 F	70010204
RC (A = 94)	Narrow stile door Forend: 270 x 24	35	L/R	SVA 2819 F	70010199
		40	L/R	SVA 2829 F	70010200
		45	L/R	SVA 2839 F	70010201

All dimension data in millimetres (mm)  
**PC** Profile cylinder **RC** Round cylinder **L** DIN left **R** DIN right

## SVI 5000 – Passive door leaf emergency-escape lock with automatic locking action

SVI 5xxx 

Mechanical emergency-escape lock with automatic locking action for double-leaf doors on the passive door leaf. The SVI 5xxx passive door leaf lock serves as a strike-box for an SVA emergency-escape lock on the active door leaf. The SVI lock is locked automatically as soon as the passive leaf is closed. Panic unlocking via lever handle, 9mm square-section follower. Corrosion-protected lock case in DIN dimensions, stainless steel faceplate included. Certified according to EN 179 and EN 1125.

### Installation

- Timber rebated door (12 mm angled strike plate)
- Timber non-rebated door (lipped strike plate)
- Timber non-rebated door (flat strike plate)
- Narrow stile door (lipped strike plate)
- Narrow stile door (flat strike plate)
- DIN left  DIN right

perforation

**B** Backset \_\_\_\_\_ mm

Required accessories (to be ordered separately):

- SVI accessories set (accessories: switch lock,
- rod striking plate, mounting accessories)
- SVI deadbolt set (contains: top deadbolt, bottom deadbolt)
- Ground keeper

### Other accessories

see Page 76

### Dimensions and installation drawings

see Page 40

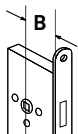

SVI 5xxx for timber doors  
(passive door leaf)

Door type	B	DIN	Type	Article no.
Rebated door Forend: 235 x 20 Angled strike plate 12 mm	65	Left	SVI 5071	70010205
		Right	SVI 5072	70010206
Non-rebated door Forend: 235 x 24 Flanged strike plate	80	Left	SVI 5081	70010207
		Right	SVI 5082	70010208
	100	Left	SVI 5091	70010209
		Right	SVI 5092	70010210
Non-rebated door Forend: 235 x 24 Flat strike plate	65	L/R	SVI 5077	70010214
	80	L/R	SVI 5087	70010215
	100	L/R	SVI 5097	70010216
Non-rebated door Forend: 235 x 24 Flat strike plate	65	L/R	SVI 5077	70010220
	80	L/R	SVI 5087	70010221
	100	L/R	SVI 5097	70010222

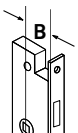

SVI 5xxx for framed doors  
(passive door leaf)

Door type	B	DIN	Type	Article no.
Narrow stile door Forend: 310 x 24 Flanged strike plate	35	L/R	SVI 5119	70010211
	40	L/R	SVI 5129	70010212
	45	L/R	SVI 5139	70010213
Narrow stile door Forend: 310 x 24 Flat strike plate	35	L/R	SVI 5119	70010217
	40	L/R	SVI 5129	70010218
	45	L/R	SVI 5139	70010219

### SVI 5xxx locking system on passive door leaf

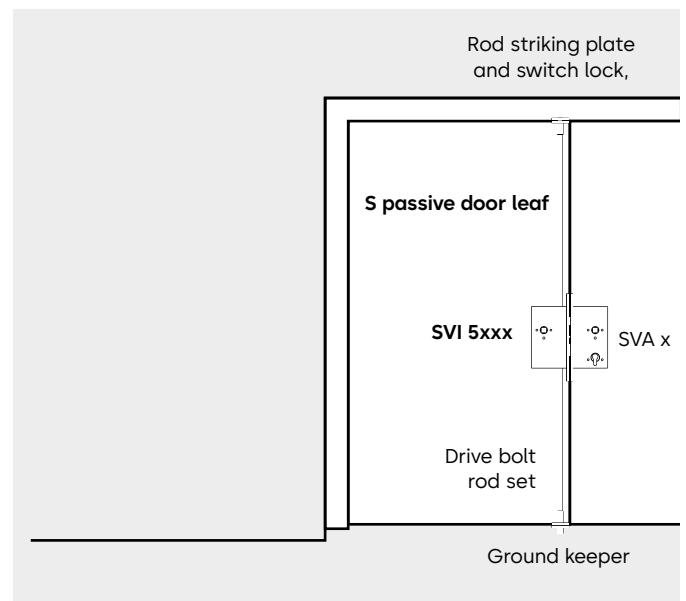

Necessary accessories can be found on page 76

# SVI 4000 – Passive door leaf emergency-escape lock with automatic locking action and electrical status monitoring

SVI 4xxx   

Electrically monitored emergency-escape lock with automatic locking action for double-leaf doors on the passive door leaf. With status monitoring of the drive deadbolt set and lever handle/panic bar. The SVI 4xxx passive door leaf lock serves as a strike-box for an SVA emergency-escape lock on the active door leaf. The SVI lock is locked automatically as soon as the passive leaf is closed.

Panic unlocking via lever handle, 9 mm square-section follower. Corrosion-protected lock case in DIN dimensions, stainless steel faceplate included. Certified in accordance with EN 179 and EN 1125 for use with panic door fittings.

Maximum load current 100 mA at max. 30 V DC

Status messages via potential-free contacts

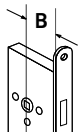

SVI 4xxx for timber doors (passive door leaf)

Door type	B	DIN	Type	Article no.
Rebated door Forend: 235 x 20 Angled strike plate 12 mm	65	Left	SVI 4071	70010223
		Right	SVI 4072	70010224
Non-rebated door Forend: 235 x 24 Flanged strike plate	80	Left	SVI 4081	70010225
		Right	SVI 4082	70010226
	100	Left	SVI 4091	70010227
		Right	SVI 4092	70010228
Non-rebated door Forend: 235 x 24 Flat strike plate	65	L/R	SVI 4077	70010232
	80	L/R	SVI 4087	70010233
	100	L/R	SVI 4097	70010234
Non-rebated door Forend: 235 x 24 Flat strike plate	65	L/R	SVI 4077	70010238
	80	L/R	SVI 4087	70010239
	100	L/R	SVI 4097	70010240

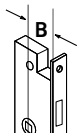

SVI 4xxx for framed doors (passive door leaf)

Door type	B	DIN	Type	Article no.
Narrow stile door Forend: 310 x 24 Flanged strike plate	35	L/R	SVI 4119	70010229
	40	L/R	SVI 4129	70010230
	45	L/R	SVI 4139	70010231
Narrow stile door Forend: 310 x 24 Flat strike plate	35	L/R	SVI 4119	70010235
	40	L/R	SVI 4129	70010236
	45	L/R	SVI 4139	70010237

## Installation

- Timber rebated door (12 mm angled strike plate)
- Timber non-rebated door (lipped strike plate)
- Timber non-rebated door (flat strike plate)
- Narrow stile door (lipped strike plate)
- Narrow stile door (flat strike plate)
- DIN left  DIN right

perforation

**B** Backset \_\_\_\_\_ mm

Required accessories (to be ordered separately):

- dormakaba SVP-A connection cable
- dormakaba cable loop/spiral cable
- SVI accessories set (accessories: switch lock, rod striking plate, mounting accessories)
- SVI deadbolt set (contains: top deadbolt, bottom deadbolt)
- Ground keeper

## Other accessories

see Page 83

## Dimensions and installation drawings

see Page 41

## SVI 4xxx locking system on passive door leaf

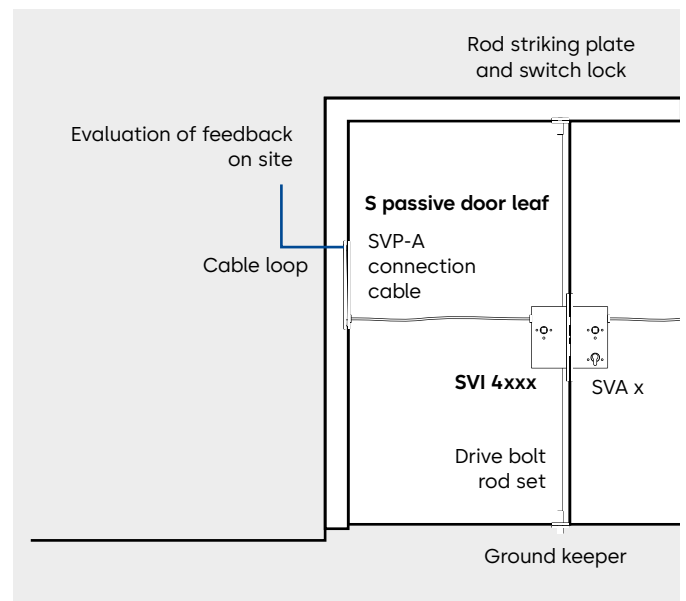

Necessary accessories can be found on page 76

# SVI 2000 F – Passive door leaf motor lock with automatic locking action and integrated power reserve module for fire and smoke doors

## SVI 2xxx F

Electrically monitored emergency-escape lock with automatic motorised locking action for double-leaf doors on the passive door leaf. With status monitoring of the drive deadbolt set and lever handle/panic bar. The SVI 2xxx F passive door leaf lock serves as a strike-box for an SVA emergency-escape lock on the active door leaf. The SVI-lock locks automatically as soon as the passive door leaf is closed. **The SVI 2000 F contains an integrated power reserve module.**

Possible operation modes: direct by analogue actuation, with external control unit SVP-S 3x DCW® (Switzerland) and SVP-S 4x DCW® (stand-alone with full functionality) or via DCW® bus to SafeRoute and/or on an electric door operator with ED 100/250 integrated control unit. LED status display shows error messages, such as incorrect operating voltage or bus connection interrupted and more!  
Panic unlocking via lever handle, 9 mm square-section follower. Corrosion-protected lock case in DIN dimensions, stainless steel faceplate included. Certified in accordance with EN 179 and EN 1125 for use with panic door fittings.

Supply voltage	24 V DC stabilised (+/- 15%)
Power input	0.05 A (max. 0.3 A)
Bus operation	DCW® bus or CAN bus (ISO 11898-3)
"Locked" signal:	Output switches to GND, 30 mA at max. 30 V DC

## Installation

- Timber rebated door (12 mm angled strike plate)
- Timber non-rebated door (lipped strike plate)
- Timber non-rebated door (flat strike plate)
- Narrow stile door (lipped strike plate)
- Narrow stile door (flat strike plate)
- DIN left  DIN right

perforation

**B** Backset \_\_\_\_\_ mm

Required accessories (to be ordered separately):

- dormakaba SVP-A connection cable
- dormakaba cable loop/spiral cable
- dormakaba TK Reed door contact
- SVI accessories set (accessories: switch lock, rod striking plate, mounting accessories)
- SVI deadbolt set (contains: top deadbolt, bottom deadbolt)
- Ground keeper

Control via

- dormakaba SVP-S3x (CH)/S4x DCW® Motor lock control unit
- SafeRoute
- Automatic operator ED 100/250

## Other accessories

see Page 76

## Dimensions and installation drawings

see Page 40

## SVI 2xxx F locking system on passive door leaf

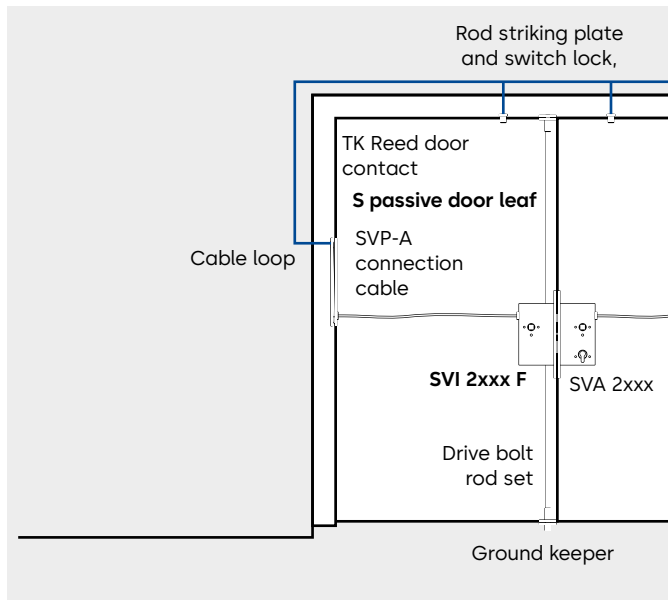

## Wiring layout

Cable colours	SVI 2xxx function
Black	GND
Brown	-
pink/grey	Bolt contact*
Red	-
White	+24 V DC
Yellow	Bolt contact*
Green	-
Grey	RS485 N
Pink	RS485 P
red/blue	-
Blue	-
Violet	Locked, output switches to GND, 30 mA at max. 30 V DC

- Not assigned

\* only for special items

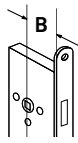

**SVI 2xxx for timber doors  
(passive door leaf)**

Door type	B	DIN	Type	Article no.
Rebated door Forend: 235 x 20 Angled strike plate 12 mm	65	Left	SVI 2071 F	70010259
		Right	SVI 2072 F	70010260
	80	Left	SVI 2081 F	70010261
		Right	SVI 2082 F	70010262
		Left	SVI 2091 F	70010263
Non-rebated door Forend: 235 x 24 Flanged strike plate	65	L/R	SVI 2077 F	70010268
	80	L/R	SVI 2087 F	70010269
	100	L/R	SVI 2097 F	70010270
Non-rebated door Forend: 235 x 24 Flat strike plate	65	L/R	SVI 2077 F	70010274
	80	L/R	SVI 2087 F	70010275
	100	L/R	SVI 2097 F	70010276

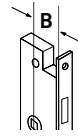

**SVI 2xxx for framed doors  
(passive door leaf)**

Door type	B	DIN	Type	Article no.
Narrow stile door Forend: 380 x 24 Flanged strike plate	35	L/R	SVI 2119 F	70010265
	40	L/R	SVI 2129 F	70010266
	45	L/R	SVI 2139 F	70010267
Narrow stile door Forend: 380 x 24 Flat strike plate	35	L/R	SVI 2119 F	70010271
	40	L/R	SVI 2129 F	70010272
	45	L/R	SVI 2139 F	70010273



Necessary accessories can be found on page 76

#### Rod lock system for SVI locks

##### SVI set

Accessories required for installing SVI locks and drive deadbolts. Contains: bottom deadbolt guide plate, mounting aid lock/drive deadbolt, dormakaba torque tool, switch lock and top frame strike plate.

	Article no.
<b>01 SVI set 20mm</b> Installation on rebate doors with angle strike plate. 20 mm top frame strike plate.	70010291
<b>SVI set 24mm</b> Installation on non-rebated or narrow stile doors with lipped or flat strike plates. 24 mm top frame strike plate	70010290

##### Drive deadbolt set

Drive deadbolt set consisting of top and bottom drive deadbolts. Used in connection with SVI locks.

	Article no.
<b>02 SVI TRS 25</b> Drive deadbolt set for doors up to 2.5 m	70932305
<b>SVI TRS 35</b> Drive deadbolt set for doors up to 3.5 m	70932306

##### Ground keeper

Ground keeper for locking device of the bottom drive dead bolt on the passive door leaf. Required for emergency exit devices according to EN 1125.

	Article no.
<b>03 PHA 2122-0 (0 mm)</b>	3501421220000
<b>PHA 2122-2 (-2 mm)</b>	3501421222000
<b>PHA 2122-4 (-4 mm)</b>	3501421224000
<b>04 PHA 2121 +/-2</b> Flexible ground keeper. Flexibly adjustable (+/- 2 mm)	3501421210000

## M-SVP – Multipoint panic lock

The substantial benefits of the M-SVP multipoint emergency-escape locks with automatic locking action include: automatic locking of doors immediately after every closure, and heightened burglar resistance.

The 3-point locking devices with rotating bolts or latch bolts and the 20 mm protrusion main bolt lock the door in an insurance-compliant manner and provide heightened burglar resistance.

The panic function of the M-SVP locks ensures that the door can be opened at any time from the inside, in the direction of escape, simply by operating the handle.

Apart from the motorised opening of doors via access control systems (radio key, transponders, etc.), mechanical unlocking from the outside is possible at any time.



### The programme includes 5 model series:

#### M-SVP 5000

Purely mechanical multipoint lock with panic function and automatic locking action

#### M-SVP 3000

Electromechanical multipoint lock with panic function, automatic locking mechanism and motorised unlocking.

#### M-SVP 2200 DCW®

Multipoint motor lock with panic function, motorised locking and unlocking as well as integrated DCW® interface

#### M-SVP 5500

Mechanical multipoint lock for double-leaf panic doors with automatic locking action

#### M-SVP 3500

Electromechanical multipoint lock for double-leaf panic doors with automatic locking action and motorised unlocking

### Benefits – point by point

- Automatic and immediate locking of doors after each closure.
- Insurance-compliant locking through 20 mm deadbolt projection, additional protection through rotating bolt or deadbolt at the top and bottom
- Enhanced burglar resistance through multipoint lock
- Thanks to the panic function, the door can be opened in the direction of escape at any time using the lever handle
- Can be used on wide and narrow stile doors, for profile and profile round cylinders
- Profile-related supply packages
- Integration in access control and TMS systems possible (not M-SVP 5000)
- Approved for use in emergency exits and escape routes, suitable for fire doors
- If there is a power failure, the door can still be locked and unlocked from the inside and the outside with the key

## **F** Verification of suitability

The M-SVP locks with automatic locking function are tested and quality-monitored by the notified body MPA in Dortmund. An approval or verification of suitability in conjunction with the respective fire and smoke door may be required.



The M-SVP locks are certified in conjunction with lever handles and panic bars from various manufacturers in accordance with EN 179 "Emergency exit devices operated by a lever handle or push pad" and EN 1125 "Panic exit devices operated by a horizontal bar", and therefore carry the conformity mark CE.

### **M-SVP – features and functions**

	M-SVP 5000	M-SVP 3000	M-SVP 2200 DCW®	M-SVP 5500	M-SVP 3500
3-point locking	●	●	●	●	●
Rotating bolts and sliding bolts	–	–	●	–	–
Latch bolts	●	●	–	●	●
Motorised automatic locking action	–	–	●	–	–
Mechanical locking	●	●	–	●	●
Motorised unlocking via access control	–	●	●	–	●
Mechanical unlocking via the lever handle (emergency escape function)	●	●	●	●	●
Mechanical unlocking via profile cylinder	●	●	●	●	●
Suitable for electronic cylinders	●	●	●	●	●
Free wheel cam cylinders (forced disengagement required)	–	–	●	–	–
Integration in access control systems	–	●	●	–	●
Permanent door release (lock latch and all deadbolts retracted)	–	●	●	–	●
Day latch function (deadbolt retracted, lock latch deployed)	–	–	●	–	–
Message "Door open/closed"	–	●	●	–	●
Message "Door locked/unlocked"	–	–	●	–	–
Message "Handle operation/panic function"	–	–	●	–	–
DCW® interface, can be directly integrated in ED	–	–	●	–	–
Adjustment range Relocking time	–	–	●	–	–
Automatic reset of the enabling when the door fails to open	–	●	●	–	●
Approval in accordance with DIN EN 179	●	●	●	●	●
Approval in accordance with DIN EN 1125	●	●	●	●	●
Approved for fire and smoke doors	●	●	●	–	–
Suitability for double-leaf escape route doors	–	–	–	●	●

● Yes – No

## Profile-related article overview

Manufacturer	Profile	M-SVP 2200 DCW®	M-SVP 3000	M-SVP 5000
<b>Akotherm</b>	AT 600	UF	UF	UF
	AT 720	UF	UF	UF
	AT 730	UF	UF	UF
	AT 740	UF	UF	UF
<b>Alcoa</b>	AA 610	FF	FF	FF
	AA 611	FF	FF	FF
	AA 630	FF	FF	FF
	AA 720	UF	UF	UF
<b>Aliplast</b>	Star 75	UU6	UU6	UU6
	Star 95	UU6	UU6	UU6
<b>ALUPROF</b>	MB-60	UU6	UU6	UU6
	MB-70	UU6	UU6	UU6
	MB-86	UU6	UU6	UU6
<b>Ferro</b>	WICSTYLE 55N	UU6.7	UU6.7	UU6.7
	WICSTYLE 70*	UU6.7	UU6.7	UU6.7
	WICSTYLE 70FP*	UU6.7	UU6.7	UU6.7
<b>Forster</b>	fuego light	UF	UF	UF
	presto 60	UU6, UF	UU6, UF	UU6, UF
	unico	FF ST29	FF ST29	FF ST29
<b>Groke</b>	Groke GT 190	40 UF	40 UF	40 UF
<b>Heroyal</b>	Series 20	UF, 40 UF, UF ST24	UF, 40 UF, UF ST24	UF, 40 UF, UF ST24
	Series 25	UF	UF	UF
	Series 65	UU6.7	UU6.7	UU6.7
	Series 90	UU6.7	UU6.7	UU6.7
	Series 110/110 ES	UU6.7	UU6.7	UU6.7
	Series 82/90	UU6	UU6	UU6
	Series D 50 C	UF	UF	UF
	Series D 65	UU6.7	UU6.7	UU6.7
Series D 72	UU6	UU6	UU6	
<b>Hörmann-Aluminium</b>	TC80	FF, 45 FF	FF, 45 FF	FF, 45 FF
<b>Hueck</b>	1.0	FF, 45 FF	FF, 45 FF	FF, 45 FF
	BSC T30	UU6	UU6	UU6
	Lambda 57 S	UF	UF	UF
	Lambda 65 M	UF	UF	UF
	Lambda 77 L	UF	UF	UF
<b>Jansen</b>	Janisol	FF	FF	FF
	Janisol 2 (T30)*	FF	FF	FF
	Janisol HI	UU6	UU6	UU6

Manufacturer	Profile	M-SVP 2200 DCW®	M-SVP 3000	M-SVP 5000
<b>Klauke</b>	Series 77	UF	UF	UF
<b>Reynaers</b>	CS 104	UU6	UU6	UU6
	CS 68 (with support plate article 15200101)	UU6, UU6.7	UU6, UU6.7	UU6, UU6.7
	CS 77	UU6	UU6	UU6
	CS 86	UU6	UU6	UU6
<b>SAPA</b>	Avantis 70	FF	FF	FF
	Avantis 75	FF	FF	FF
<b>Schüco</b>	ADS 60 HD	UU6	UU6	UU6
	ADS 65 NI.SP	FF ST28		
	ADS 70 HD	UU6	UU6	UU6
	ADS 75 HD	UU6	UU6	UU6
	ADS 80 FR30	FF ST28		
	ADS 90 BR	UU6	UU6	UU6
<b>Sykon</b>	Series 60	UF	UF	UF
	Sykotherm 70	UU6.7	UU6.7	UU6.7
	Sykotherm 75	UU6.7	UU6.7	UU6.7
	Sykotherm 75 Plus	UU6.7	UU6.7	UU6.7
<b>TKI</b>	755	UU6.7	UU6.7	UU6.7
<b>Wicona</b>	FP T30	UU6	UU6	UU6
	WICSTYLE 60N	UU6.7	UU6.7	UU6.7
	WICSTYLE 65	45 FF	45 FF	45 FF
	WICSTYLE 65 evo	FF	FF	FF
	WICSTYLE 65N	FF, 45 FF	FF, 45 FF	FF, 45 FF
	WICSTYLE 70NFP	UU6.7	UU6.7	UU6.7
	WICSTYLE 75 evo **	FF, 45 FF	FF, 45 FF	FF, 45 FF
	WICSTYLE 77	FF, 45 FF	FF, 45 FF	FF, 45 FF
	WICSTYLE 77FP	FF	FF	FF
	WICSTYLE 88	FF	FF	FF

Variants for further profile systems upon request

The specified profiles are recommendations from dormakaba. Please ask your system provider for a binding statement on the usability

\*adaptation to the profile may be required

\*\*Tool tip (with 24 mm forend/striking strip mounting profile)

## M-SVP 5000 – Multipoint panic lock with automatic locking action

Multipoint panic lock with automatic locking action and latch bolts/main bolts in anti-force-back design. Heightened burglar resistance. Transmission function for unlocking from the outside using a key.

The integrated panic function ensures that the door can be opened in the escape direction at any time simply by using the lever handle. The automatic locking mechanism is automatically triggered by magnets when the door is closed.

- Steel latch bolts and main locks, 20 mm protrusion
- 9 mm square-section follower
- For use in wooden, PVC and aluminium doors
- Approved in escape route doors in accordance with DIN EN 179 and DIN EN 1125
- Suitable for use in fire and smoke doors

Supply sets consisting of:

- M-SVP 5000 lock
- Striking strip or striking plates and accessories
- Installation manual and milling drawing

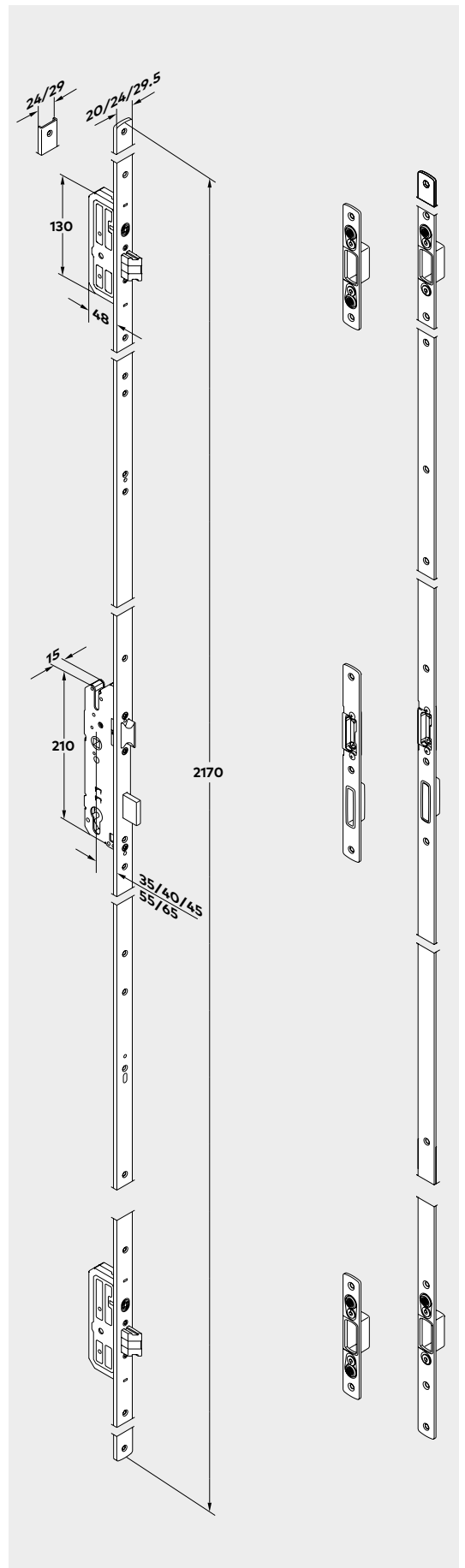

### Supply sets for steel and aluminium narrow stile doors

Product description	Forend	Striking strip	Striking plates	Backset	Distance	DIN	Lock cylinder	Article no.
<b>U forend</b>								
M-SVP 5000 UU6	U 6 x 24	U 5.5 x 24		35	92	L	PC	15500001
						R	PC	15500002
						L	RC	15500031
						R	RC	15500032
M-SVP 5000 UU6,7	U 6.7 x 24	U 5.5 x 24		35	92	L	PC	15500003
						R	PC	15500004
M-SVP 5000 UF	U 6 x 24	F 3 x 24		35	92	L	PC	15500005
						R	PC	15500006
						L	RC	15500035
						R	RC	15500036
M-SVP 5000 40 UF	U 6 x 24	F 3 x 24		40	92	L	PC	15500009
						R	PC	15500010
						L	RC	15500039
						R	RC	15500040
M-SVP 5000 UF ST24	U 6 x 24		3 x 24	40	92	L	PC	15500017
						R	PC	15500018
						L	RC	15500047
						R	RC	15500048
<b>Flat forend</b>								
M-SVP 5000 FF	F 3 x 24	F 3 x 24		35	92	L	PC	15500007
						R	PC	15500008
						L	RC	15500037
						R	RC	15500038
M-SVP 5000 45 FF	F 3 x 24	F 3 x 24		45	92	L	PC	15500011
						R	PC	15500012
M-SVP 5000 FF ST29	F 2.5 x 29.5		2.5 x 29.5	35	92	L	PC	15500019
						R	PC	15500020
						L	RC	15500049
						R	RC	15500050

### Supply sets for wooden doors

Product description	Forend	Striking strip	Striking plates	Backset	Distance	DIN	Lock cylinder	Article no.
M-SVP 5000 H 55/92	F 2.7 x 20		8.5 x 20	55	92	L	PC	15500025
						R	PC	15500026
M-SVP 5000 H 65/92	F 2.7 x 20		8.5 x 20	65	92	L	PC	15500027
						R	PC	15500028
M-SVP 5000 H 65/94	F 2.7 x 20		8.5 x 20	65	94	L	RC	15500057
						R	RC	15500058

All dimension data in millimetres (mm)

L = DIN-L R = DIN-R

## M-SVP 3000 – Multipoint emergency-escape lock with automatic locking action

Electromechanical multipoint panic lock with automatic locking action and latch bolts and main bolts in anti-force-back design. Heightened burglar resistance.

Motorised unlocking (short-term and permanent unlocking) via access control systems, transmission function for unlocking from the outside using a key.

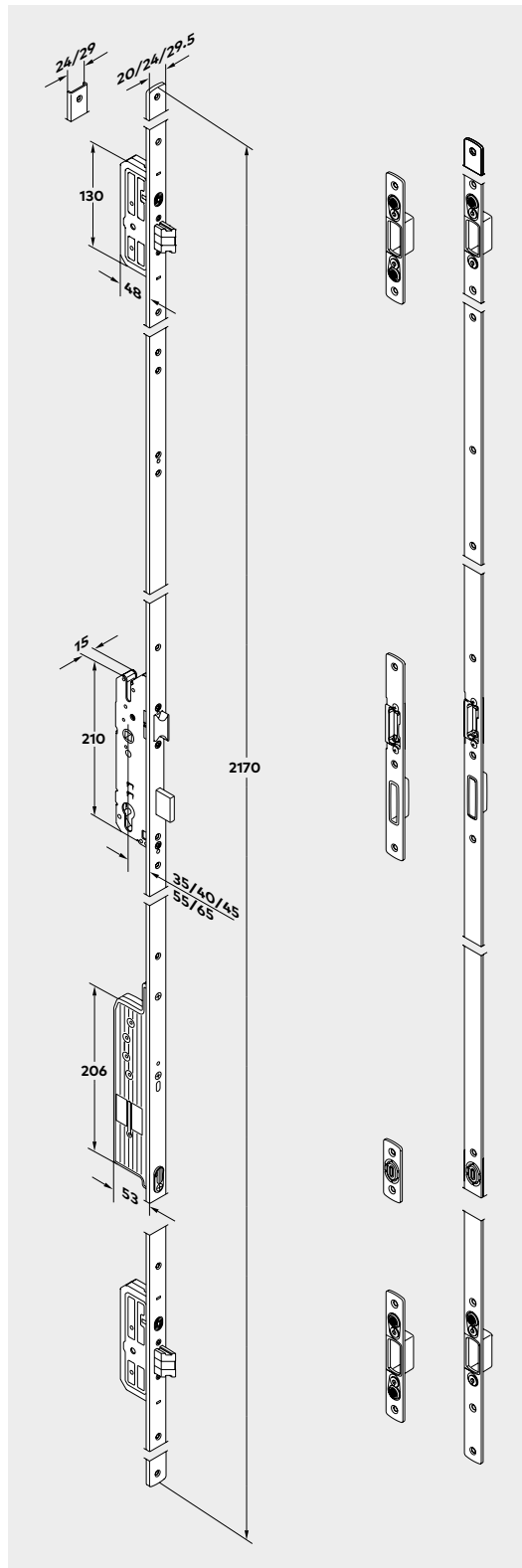

The integrated panic function ensures that the door can be opened in the escape direction at any time simply by operating the lever handle.

The automatic locking mechanism is automatically triggered by magnets when the door is closed.

- Connection of external access control systems possible
- Designed for use in escape route security systems
- Steel latch bolts and main locks, 20 mm protrusion
- 9 mm square-section follower
- Operating voltage 12 V DC
- For use in wooden, PVC and aluminium doors
- Approved in escape route doors in accordance with DIN EN 179 and DIN EN 1125
- Suitable for use in fire and smoke doors

Supply sets consisting of:

- M-SVP 3000 lock
- Striking strip or striking plates and accessories
- 10 m connection cable
- Installation manual and milling drawing

### Required accessories

(to be ordered separately):

- M-SVP 3000 Control unit
- dormakaba KÜ/KS cable loop/spiral cable/LK detachable cable loop  
see Page 77

### M-SVP 3000 Control unit

Control unit for operation of the M-SVP 3000 electro-mechanical multipoint panic lock with automatic locking action.

- Makes motorised unlocking of the door possible, via different access control systems
- Mounted in surface-mounted housing, including power supply unit
- Supply voltage: 230 V AC +/- 10%.
- Housing dimensions  
(W x H x D): approx. 112 x 200 x 84 mm

Order no. 1650000218

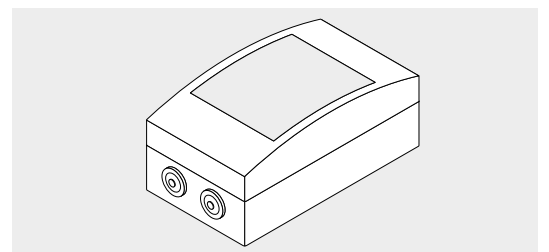

### Supply sets for steel and aluminium narrow stile doors

Product description	Forend	Striking strip	Striking plates	Backset	Distance	DIN	Lock cylinder	Article no.
<b>U forend</b>								
M-SVP 3000 UU6	U 6 x 24	U 5.5 x 24		35	92	L	PC	15300001
						R	PC	15300002
						L	RC	15300031
						R	RC	15300032
M-SVP 3000 UU6,7	U 6.7 x 24	U 5.5 x 24		35	92	L	PC	15300003
						R	PC	15300004
M-SVP 3000 UF	U 6 x 24	F 3 x 24		35	92	L	PC	15300005
						R	PC	15300006
						L	RC	15300035
						R	RC	15300036
M-SVP 3000 40 UF	U 6 x 24	F 3 x 24		40	92	L	PC	15300009
						R	PC	15300010
						L	RC	15300039
						R	RC	15300040
M-SVP 3000 UF ST24	U 6 x 24		3 x 24	40	92	L	PC	15300017
						R	PC	15300018
						L	RC	15300047
						R	RC	15300048
<b>Flat forend</b>								
M-SVP 3000 FF	F 3 x 24	F 3 x 24		35	92	L	PC	15300007
						R	PC	15300008
						L	RC	15300037
						R	RC	15300038
M-SVP 3000 45 FF	F 3 x 24	F 3 x 24		45	92	L	PC	15300011
						R	PC	15300012
M-SVP 3000 FF ST29	F 2.5 x 29.5		2.5 x 29.5	35	92	L	PC	15300019
						R	PC	15300020
						L	RC	15300049
						R	RC	15300050

### Supply sets for wooden doors

Product description	Forend	Striking strip	Striking plates	Backset	Distance	DIN	Lock cylinder	Article no.
M-SVP 3000 H 55/92	F 2.7 x 20		8.5 x 20	55	92	L	PC	15300025
						R	PC	15300026
M-SVP 3000 H 65/92	F 2.7 x 20		8.5 x 20	65	92	L	PC	15300027
						R	PC	15300028
M-SVP 3000 H 65/94	F 2.7 x 20		8.5 x 20	65	94	L	RC	15300057
						R	RC	15300058

All dimension data in millimetres (mm)

L = DIN-L R = DIN-R

## M-SVP 2200 DCW® – Multipoint motor lock with automatic locking action and emergency escape function

Multipoint motor lock with automatic locking action and panic function. It has one rotating bolt and one bolt each at the top and the bottom of the lock for a particularly firm blocking lever, as well as a main lock with 20 mm projection. Heightened burglar resistance.

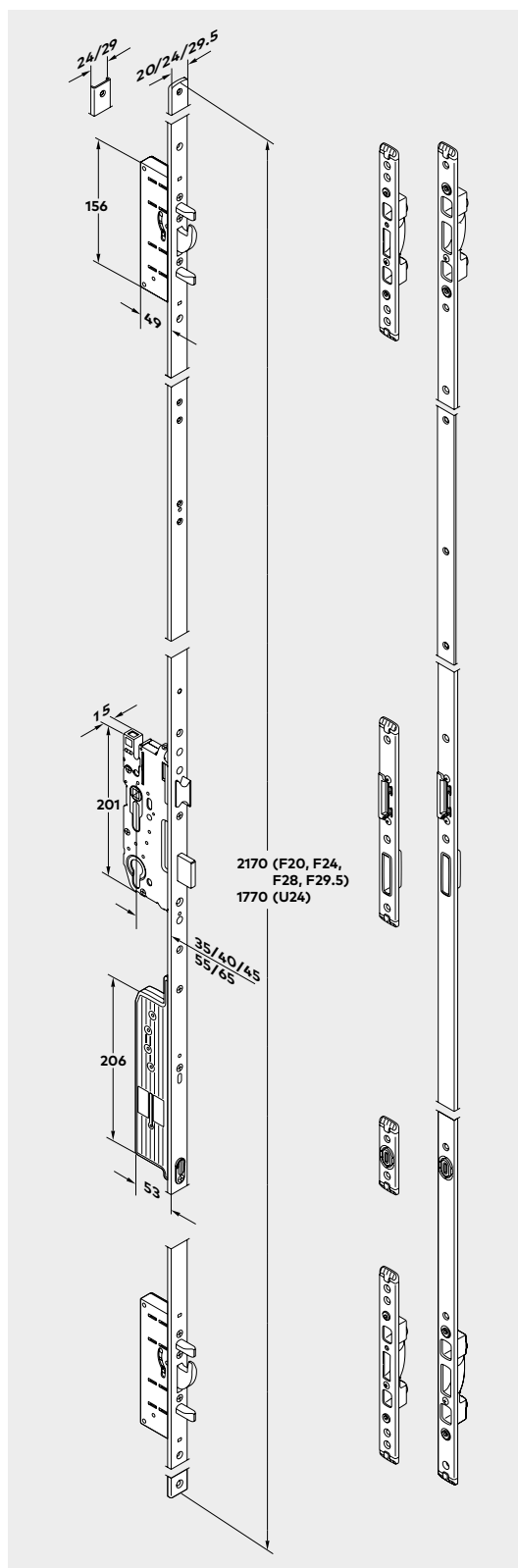

Motorised unlocking (short-term and permanent unlocking, plus additional day latch function) via access control systems, transmission function for unlocking from the outside using a key. The integrated panic function ensures that the door can be opened in the escape direction at any time simply by using the door fitting. Certified according to EN 179 and EN 1125 for use with panic door fittings.

Motorised automatic locking takes place automatically when the door is closed. If a SafeRoute escape route security system or an ED swing door operator with a DCW® upgrade card is installed, the M-SVP 2200 DCW® can even be connected directly via the DCW® and operated with full functionality – without the need for a separate control unit. With limited functionality, an M-SVP 2200 can also be used without SafeRoute, ED 100/250 or without a control unit.

The optional SVP-S4x DCW® control unit can be used to operate the M-SVP 2200 DCW® with its full range of functions, even in stand-alone mode.

With the following feedback:

"door open/closed", "door locked/unlocked", "handle operation/emergency unlocking".

- Steel bolts, rotating bolts and main locks
- Main lock, projection 20 mm.
- 9 mm square-section follower
- Free wheel cam cylinders (forced disengagement required)
- Operating voltage 24 V DC
- For use in wooden, PVC and aluminium doors
- Approved for use in emergency exit doors in accordance with DIN EN 179 and DIN EN 1125
- Suitable for use in fire and smoke doors with M-SVP PR DCW® module

Supply sets consisting of:

- M-SVP 2200 DCW® lock
- Striking strip or striking plates and accessories
- 10 m connection cable
- Including Installation manual and milling drawing

### Required accessories

(to be ordered separately):

dormakaba cable transition/cable loop/LK detachable cable transfer see Page 77

Optional:

SVP-S4x/3x DCW® control unit, M-SVP PR DCW® module see Page 82

### Supply sets for steel and aluminium narrow stile doors

Product description	Forend	Striking strip	Striking plates	Backset	Distance	DIN	Lock cylinder	Article no.
<b>U forend</b>								
M-SVP 2200 DCW® UU6	U 6 x 24	U 5.5 x 24		35	92	L	PC	15202001
						R	PC	15202002
M-SVP 2200 DCW® UU6,7	U 6.7 x 24	U 5.5 x 24		35	92	L	RC	15202031
						R	RC	15202032
M-SVP 2200 DCW® UF	U 6 x 24	F 3 x 24		35	92	L	PC	15202005
						R	PC	15202006
M-SVP 2200 DCW® UF	U 6 x 24	F 3 x 24		35	94	L	RC	15202035
						R	RC	15202036
M-SVP 2200 DCW® 40 UF	U 6 x 24	F 3 x 24		40	92	L	PC	15202009
						R	PC	15202010
M-SVP 2200 DCW® UF 65/72	U 6 x 24	F 3 x 24		65	72	L	PC	15202015
						R	PC	15202016
M-SVP 2200 DCW® UF ST24	U 6 x 24		3 x 24	40	92	L	PC	15202017
						R	PC	15202018
M-SVP 2200 DCW® UF ST24	U 6 x 24		3 x 24	40	94	L	RC	15202047
						R	RC	15202048
<b>Flat forend</b>								
M-SVP 2200 DCW® FF	F 3 x 24	F 3 x 24		35	92	L	PC	15202007
						R	PC	15202008
M-SVP 2200 DCW® FF	F 3 x 24	F 3 x 24		45	92	L	RC	15202037
						R	RC	15202038
M-SVP 2200 DCW® 45 FF	F 3 x 24	F 3 x 24		45	92	L	PC	15202011
						R	PC	15202012
M-SVP 2200 DCW® FF ST29	F 2.5 x 29.5		2.5 x 29.5	35	92	L	PC	15202019
						R	PC	15202020
M-SVP 2200 DCW® FF ST29	F 2.5 x 29.5		2.5 x 29.5	35	94	L	RC	15202049
						R	RC	15202050

All dimension data in millimetres (mm)

L = DIN-L R = DIN-R

## M-SVP 2200 DCW® – Multipoint motor lock with automatic locking action and emergency escape function

### Supply sets for wooden doors

Product description	Forend	Striking strip	Striking plates	Backset	Distance	DIN	Lock cylinder	Article no.
M-SVP 2200 DCW® H 55/92	F 2.7 x 20		8.5 x 20	55	92	L	PC	15202025
						R	PC	15202026
M-SVP 2200 DCW® H 65/92	F 2.7 x 20		8.5 x 20	65	92	L	PC	15202027
						R	PC	15202028
M-SVP 2200 DCW® H 55/72	F 2.7 x 20		8.5 x 20	55	72	L	PC	15202021
						R	PC	15202022
M-SVP 2200 DCW® H 65/72	F 2.7 x 20		8.5 x 20	65	72	L	PC	15202023
						R	PC	15202024
M-SVP 2200 DCW® H 65/74	F 2.7 x 20		8.5 x 20	65	74	L	RC	15202043
						R	RC	15202044
M-SVP 2200 DCW(R) H 65/72	rund F3 x 24		3 x 24 mm without centre striking plate	65	72	L/R	PC	15202053
M-SVP 2200 DCW(R) H 80/72			3 x 24 mm without centre striking plate	80	72	L/R	PC	15202055

All dimension data in millimetres (mm)

L = DIN-L R = DIN-R

## M-SVP accessories

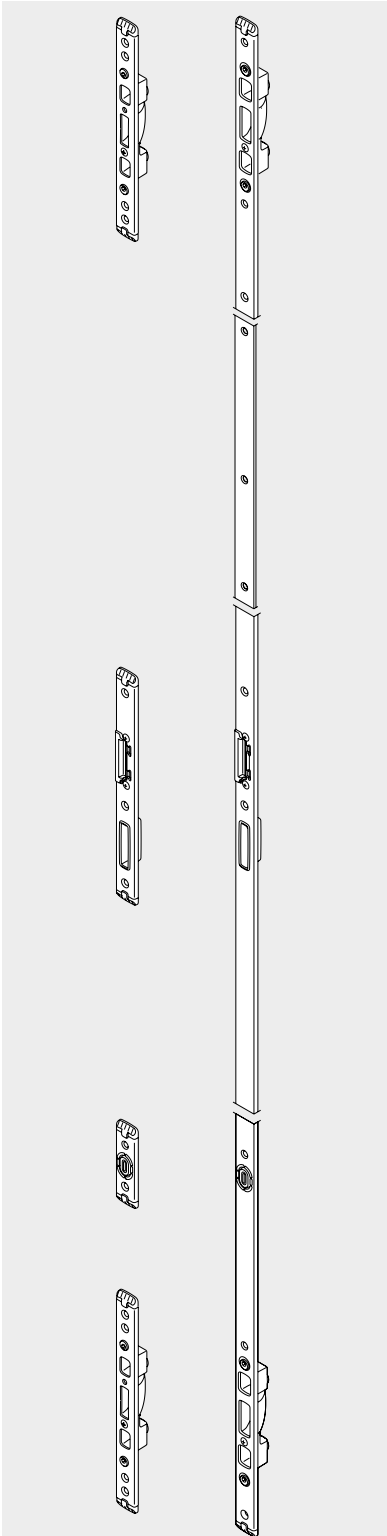
	Specification text	Article no.
	<b>Striking strip for use with the M-SVP 2200 DCW® on steel and aluminium narrow stile doors</b>	
	Striking strip F24 DIN-L	15202105
	Striking strip F24 DIN-R	15202106
	Striking strip U24 DIN-L	15202107
	Striking strip U24 DIN-R	15202108
	<b>Striking strip for use with the M-SVP 2200 DCW® on wooden doors</b>	
	Striking strip DIN non handed	15202103
	<b>Striking plates for use with the M-SVP 2200 DCW® on steel and aluminium narrow stile doors</b>	
	Striking plates, set, F24 DIN-L	15202115
	Striking plates, set, F24 DIN-R	15202116
	Striking plates, set, U24 DIN-L	15202117
	Striking plates, set, U24 DIN-R	15202118
	<b>Striking plates for use with the M-SVP 2200 DCW® on wooden doors</b>	
	Locking components, set, DIN non handed	15202113

## M-SVP 5500 – Multipoint panic lock with automatic locking action for the active door leaf of double-leaf doors

Multipoint panic lock with automatic locking action for the active door leaf of double-leaf doors.

Increased burglar resistance up to resistance class RC-3 in suitable door systems. The automatic locking mechanism is automatically triggered by magnets when the door is closed.

The integrated panic function ensures that the door can be opened in the escape direction through a simple actuation of the operating element in accordance with EN 179 or EN 1125 (for example, lever handle or panic bar). Can be combined with horizontal pushbar dormakaba PHA 2501 and panic bars from other suppliers as per test certificate. Rotational angle at least 30°.

- 9 mm square-section follower
- Steel latch bolts and deadbolts, 20 mm protrusion
- For use in aluminium doors.
- Transmission function for unlocking from the outside using a key.
- Approved for use in escape routes in accordance with EN 179 and EN 1125
- Suitable for use in fire and smoke doors

Supply sets consisting of:

- M-SVP 5500 lock
- Accessories
- Installation manual
- Milling drawing

### M-SVP-GK

Panic second leaf lock for automatic locking action in the passive door leaf of double-leaf full panic doors; for combination with M-SVP 3500 and M-SVP 5500 multipoint panic locks with automatic locking action on the active door leaf side.

Supply set consisting of:

- Second leaf lock including latch guides
- Ground keeper
- Switch lock incl. mounting accessories
- Shoot bolt including shoot bolt guide
- Carry bar
- Striking plates
- Magnetic contact
- Installation manual
- Milling drawing

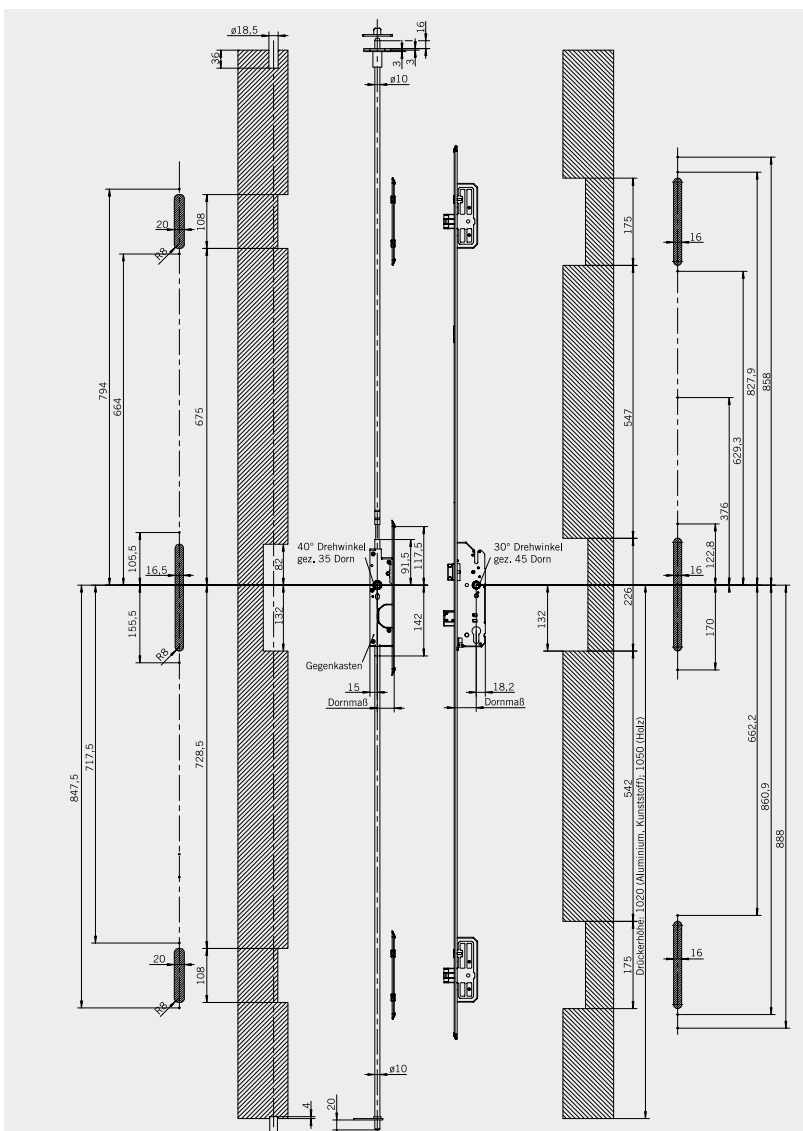

## M-SVP 5500 - Supply sets

### Supply sets M-SVP 5500

Product description	Forend	Striking plates	Backset	Distance	DIN	Lock cylinder	Article no.
<b>U forend</b>							
M-SVP 5500 40 U6	U forend 6 x 24		40	92	L/R	PC	15520002
M-SVP 5500 45 U6,7	U forend 24 x 6.7		45	92	L/R	PC	15520003

### Supply sets M-SVP second leaf lock

Product description	Forend	Striking plates	Backset	Distance	DIN	Lock cylinder	Article no.
M-SVP second leaf lock 35 U24 x 4.2	U forend 4.2 x 24 mm	U striking plates	35		L/R	–	15330001
M-SVP second leaf lock 45 U24 x 4.2	U forend 4.2 x 24 mm	U striking plates	45		L/R	–	15330003
<b>Flat forend</b>							
M-SVP second leaf lock 35 F24 x 2.7	Flat forend F 2.7 x 24 mm	F striking plates	35		L/R	–	15330002

## Profile combinations

### M-SVP 5500

Profiles	Lock version/active door leaf		Second leaf lock version/passive door leaf	
	Automatic multipoint locking mechanical	Article no.	Second leaf lock set mechanical	Article no.
Akotherm AT 730/Profile 2467-2472	M-SVP 5500 40 U6	15520002	M-SVP GK 35 F	15330002
Blyweert Triton	M-SVP 5500 40 U6	15520002	M-SVP GK 35 U	15330001
Heroal 025/Profile 12592-12581	M-SVP 5500 40 U6	15520002	M-SVP GK 35 F	15330002
Heroal 065	M-SVP 5500 45 U6,7	15520003	M-SVP GK 45 U	15330003
Heroal 110 E	M-SVP 5500 45 U6,7	15520003	M-SVP GK 45 U	15330003
Klauke Series 77/Profile 77155-77161	M-SVP 5500 40 U6	15520002	M-SVP GK 35 F	15330002
Reynears CS 68	M-SVP 5500 40 U6	15520002	M-SVP GK 35 U	15330001
Reynears CS 77	M-SVP 5500 40 U6	15520002	M-SVP GK 35 U	15330001
Schueco ADS 65 HD	M-SVP 5500 40 U6	15520002	M-SVP GK 35 U	15330001
Schueco ADS 70 HD	M-SVP 5500 40 U6	15520002	M-SVP GK 35 U	15330001
Schueco ADS 75 SIHD	M-SVP 5500 40 U6	15520002	M-SVP GK 35 U	15330001
Sprangers	M-SVP 5500 40 U6	15520002	M-SVP GK 35 U	15330001
Sykotherm VK75	M-SVP 5500 40 U6	15520002	M-SVP GK 35 U	15330001
TKI 755 / Profile 755-02-061/755-02-063	M-SVP 5500 40 U6	15520002	M-SVP GK 35 U	15330001

## M-SVP 3500 – Multipoint panic lock with automatic locking action for the active door leaf of double-leaf doors

Multipoint panic lock with automatic locking action for the active door leaf of double-leaf doors; with motorised unlocking (short-term and permanent unlocking) via access control. Increased burglar resistance up to resistance class RC-3 in suitable door systems.

The integrated emergency escape function ensures that the door can be opened in the direction of escape through a simple actuation of the operating element in accordance with EN 179 or EN 1125 (for example, lever handle or panic bar). Can be combined with horizontal pushbar dormakaba PHA 2501 and panic bars from other suppliers as per test certificate. Rotational angle on active leaf at least 30°, on inactive leaf 40°.

- 9 mm square-section follower
- Steel latch bolts and main locks, 20 mm protrusion
- For use in aluminium doors. Transmission function for unlocking from the outside using a key
- Approved for use in escape routes in accordance with EN 179 and EN 1125

Supply sets consisting of:

- M-SVP 5500 lock
- Accessories
- Connection cable
- Installation manual
- Milling drawing

Required accessory (must be ordered separately):

- dormakaba KÜ/KS cable transition/cable spiral / LK detachable cable transition

### M-SVP-GK

Panic second leaf lock for automatic locking action in the passive door leaf of double-leaf full panic doors; for combination with M-SVP 3500 and M-SVP 5500 multipoint panic locks with automatic locking action on the active door leaf side.

Supply set consisting of:

- Second leaf lock including latch guides
- Ground keeper
- Switch lock incl. mounting accessories
- Shoot bolt including shoot bolt guide
- Carry bar
- Striking plates
- Magnetic contact
- Installation manual
- Milling drawing

### M-SVP 3000 Control unit

Control unit for operation of the M-SVP 3000 electro-mechanical multipoint panic lock with automatic locking action.

- Makes motorised unlocking of the door possible, via different access control systems
- Mounted in surface-mounted housing, including power supply unit
- Supply voltage: 230 V AC +/- 10%.
- Housing dimensions (W x H x D): approx. 112 x 200 x 84 mm

Order no.

1650000218

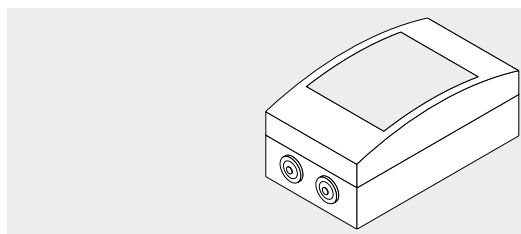
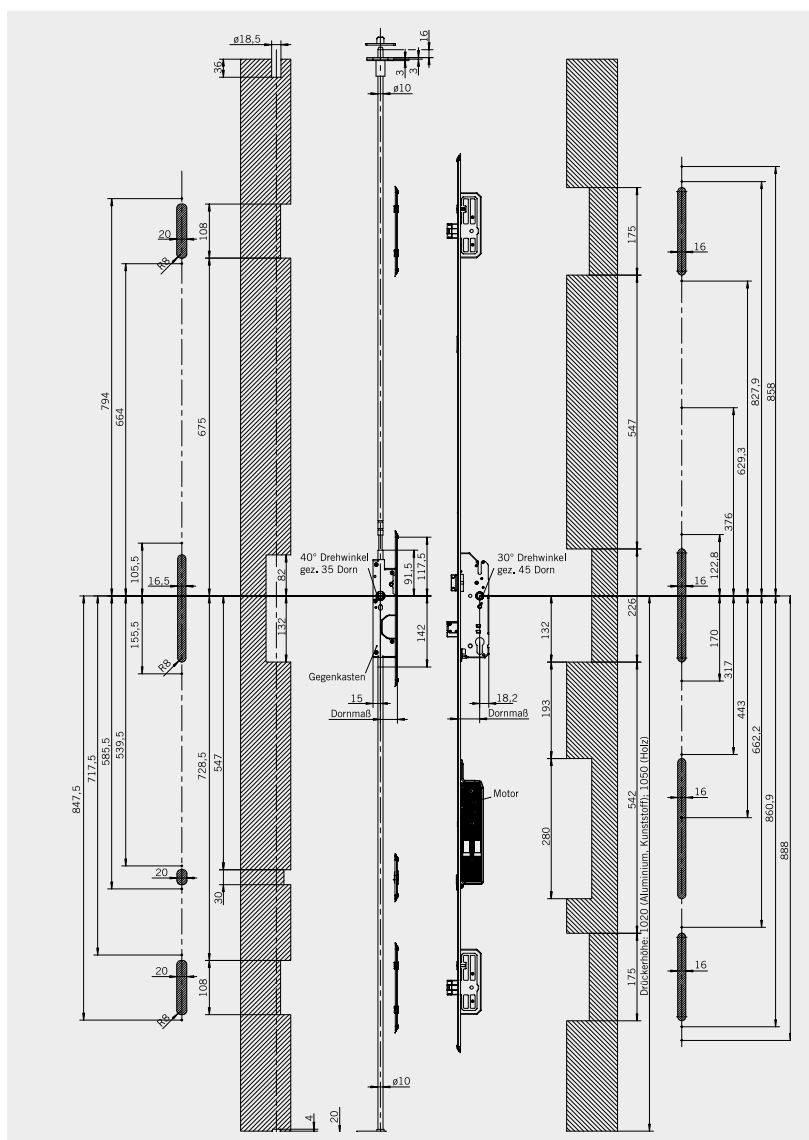

# M-SVP 3500 - Supply sets

## Supply sets M-SVP 3500

Product description	Forend	Striking plates	Backset	Distance	DIN	Lock cylinder	Article no.
<b>U forend</b>							
M-SVP 3500 RR 40 U6	U forend 6 x 24		40	92	L/R	PC	15320002
M-SVP 3500 RR 45 U6,7	U forend 24 x 6.7		45	92	L/R	PC	15320003

## Supply sets M-SVP second leaf lock

Product description	Forend	Striking plates	Backset	Distance	DIN	Lock cylinder	Article no.
M-SVP second leaf lock 35 U24 x 4.2	U forend 4.2 x 24 mm	U striking plates	35		L/R	–	15330001
M-SVP second leaf lock 45 U 24 x 4.2	U forend 4.2 x 24 mm	U striking plates	45		L/R	–	15330003
<b>Flat forend</b>							
M-SVP second leaf lock 35 F 24 x 2.7	Flat forend F 2.7 x 24 mm	F striking plates	35		L/R	–	15330002

# Profile combinations

## M-SVP 3500 RR

Profiles	Lock version/active door leaf		Second leaf lock version/passive door leaf	
	Automatic multipoint locking motorised with feedback contacts	Article no.	Second leaf lock set mechanical	Article no.
Akothem AT 730/Profile 2467-2472	M-SVP 3500 RR 40 U6	15320002	M-SVP GK 35 F	15330002
Blyweert Triton	M-SVP 3500 RR 40 U6	15320002	M-SVP GK 35 U	15330001
Heroal 025/Profile 12592-12581	M-SVP 3500 RR 40 U6	15320002	M-SVP GK 35 F	15330002
Heroal 065	M-SVP 3500 RR 45 U6,7	15320003	M-SVP GK 45 U	15330003
Heroal 110 E	M-SVP 3500 RR 45 U6,7	15320003	M-SVP GK 45 U	15330003
Klauke Series 77/Profile 77155-77161	M-SVP 3500 RR 40 U6	15320002	M-SVP GK 35 F	15330002
Reynears CS 68	M-SVP 3500 RR 40 U6	15320002	M-SVP GK 35 U	15330001
Reynears CS 77	M-SVP 3500 RR 40 U6	15320002	M-SVP GK 35 U	15330001
Schueco ADS 65 HD	M-SVP 3500 RR 40 U6	15320002	M-SVP GK 35 U	15330001
Schueco ADS 70 HD	M-SVP 3500 RR 40 U6	15320002	M-SVP GK 35 U	15330001
Schueco ADS 75 SI HD	M-SVP 3500 RR 40 U6	15320002	M-SVP GK 35 U	15330001
Sprangers	M-SVP 3500 RR 40 U6	15320002	M-SVP GK 35 U	15330001
Sykothem VK75	M-SVP 3500 RR 40 U6	15320002	M-SVP GK 35 U	15330001
TKI 755 / Profile 755-02-061/755-02-063	M-SVP 3500 RR 40 U6	15320002	M-SVP GK 35 U	15330001

## Accessories for (M-) SVx locks

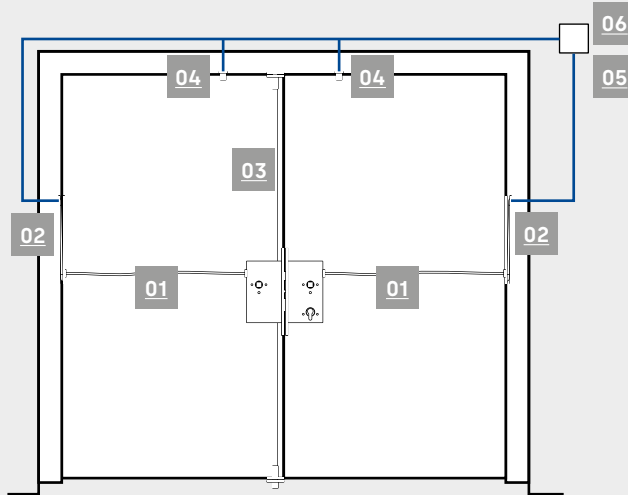

Depending on the type of lock and its application, specially designed accessories are required.

- 01** SVP/SVA/SVI connection cable
- 02** Cable loop
- 03** Rod lock system for SVI locks
- 04** TK Reed door contact
- 05** Power supply unit
- 06** SVP-S motor lock control unit



### Connection cable

SVP-A 1100 connection cable. Highly flexible, 12-core, with coupling notched on one side for reverse-polarity protected connection to SVx 4000, 6000 and 2000 (F) locks.

	Article no.
<b>SVP-A 1100</b> Length = 10 m, Ø = 6,5 mm	70932992
<b>SVP-A 2100</b> Length = 20 m, Ø = 6,5 mm	70932993



### Power supply units

#### PSU 24 flush-mounted power supply unit

Switching power supply unit as per EN 60950 for installation in standard switch box, for power supply with direct current to dormakaba electric strikes, locks (except M-SVP) or control units.  
Connection wattage: 230 V AC +/-10% 50/60 Hz, output value: 24 V DC, 600 mA, output power: 12 W, dimensions: 51 x 51 x 24 mm (max. diagonal 55 mm), installation in standard switch box Ø 65 mm

#### NT-12 5, 12 V DC

NT-12 V DC, 5 A, power supply unit for top hat rail mounting, 4 TE  
Note: not suitable for SVA/SVI 2000

#### NT-24 XS 2.5, 24 V DC (replaces 56125100)

NT-24 XS 2.5, power supply unit for DIN rail mounting  
Input voltage: 100-240 V, Output voltage: 24 V DC +/- 1% 2.5 A, for installation in housing or control cabinets with at least IP 30, temperature range: -10 - +50°C, dimensions (W x H x D): 55 x 95 x 69 / 3 DU

#### RZ-01 power supply unit 24 DC

Connected wattage: 230 AC +/-10%, maximum output current: 600 mA, in plastic housing IP21 with operating status indicator with LED, dimensions (W x H x D) approx. 160 x 80 x 50 mm

### PR DCW® Power reserve module

Additional module for guaranteeing automatic relock in case of power failure; imperative for use in fire and smoke doors.

	Article no.
<b>SVP-PR DCW®</b> In SVP 2000 F, the PR module is integrated in the lock.	70922601
<b>M-SVP-PR DCW®</b> (not shown) Power reserve module for M-SVP series	70922603

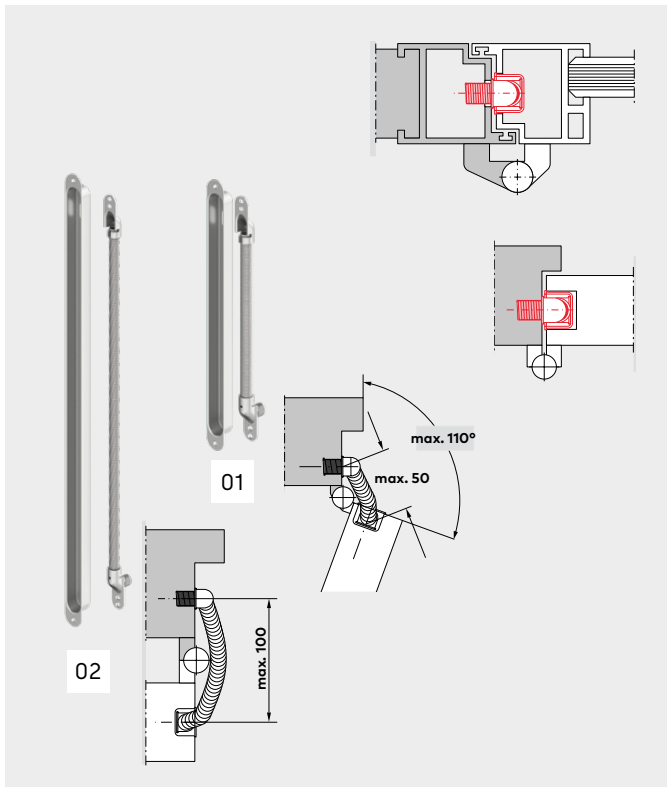

### Cable loop, reinforced spring

Robust stainless steel spiral with installation case for inserting flexible connection cables of up to  $\varnothing 7.5$  mm. Guarantees a crush-free and tamper-proof connection between the leaf and frame of doors and windows.

	<b>Article no.</b>
<b>01 Cable loop 260</b> Cable loop for door hinges with a pivot point of up to 18 mm and opening angle of up to 110°, length of the flexible spiral: 155 mm, installation dimensions of the installation case (B x H x D): approx. 24 x 260 x 17 mm	15811000
<b>02 KÜ 480</b> Cable loop for door hinges with a pivot point of up to 36 mm and opening angle of up to 180°, length of the flexible spiral: 370 mm, installation dimensions of the installation case (B x H x D): approx. 24 x 480 x 17 mm	15813000

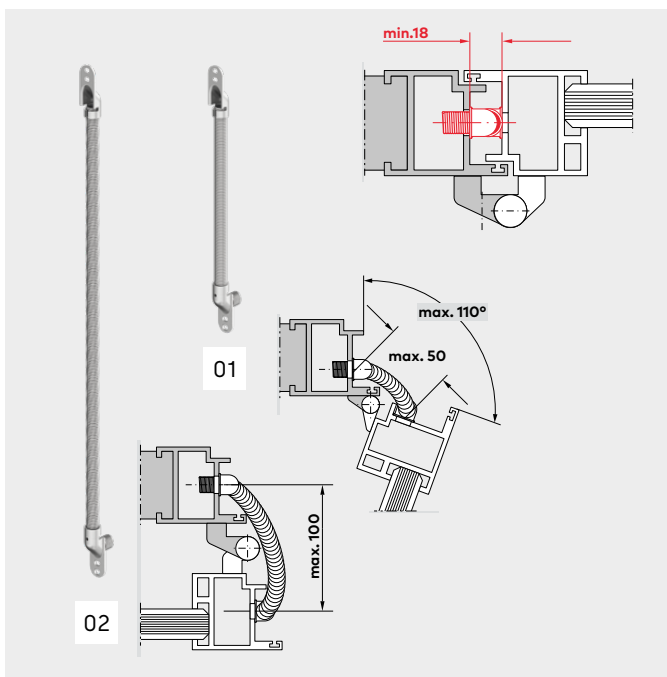

### KS Spiral cable, reinforced spring

Robust stainless steel spiral with installation case for inserting flexible connection cables of up to  $\varnothing 7.5$  mm. Guarantees a crush-free and tamper-proof connection between the leaf and frame of doors and windows.

	<b>Article no.</b>
<b>01 KS 155</b> For door hinges with a pivot point of up to 18 mm and opening angle of up to 110°, length of the flexible spiral: 155 mm, installation dimensions (W x H x D) approx.: 17 x 255 x 15 mm	15817000
<b>02 KS 370</b> For door hinges with a pivot point of up to 36 mm and opening angle of up to 180°, length of the flexible spiral: 370 mm, installation dimensions (W x H x D) approx.: 17 x 470 x 15 mm	15819000

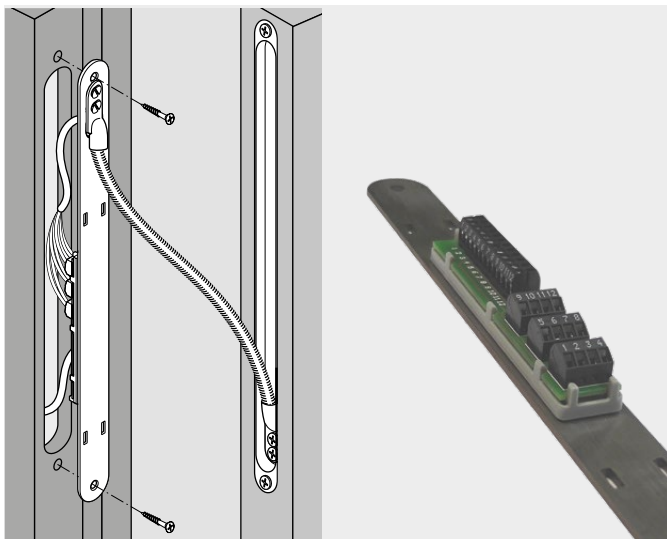

### LK-12 Detachable cable loop plug connection

Detachable cable loop plug connection for installation in the door frame, can be combined with the cable loops KÜ and spiral cables KS. 12-wire, with rear-side connection terminals. The plug-in screw terminal allows for an easy plugging-in and unplugging of the connection cables of SVP or M-SVP locks for flexible and quick installation, disassembly and maintenance of the door.

Dimensions (W x H x D): 24 x 300 x 3 mm  
 Dimensions including PCB (W x H x D): 24 x 300 x 20 mm  
 Maximum current-carrying capacity: 2 A  
 Maximum voltage: 48 V DC  
 Maximum cable cross-section for each connection:  $\varnothing 0.8$  mm

	<b>Article no.</b>
<b>LK-12</b>	15813010



**SVx U - forend**

**Article no.**

U-Shaped forend for SVP and SVA lock series, material: stainless steel, including 2 plastic end caps and screws for assembly with SVP and SVA NG narrow stile locks. U6 x 24 x 270 mm

SVP5000 forend 24 U6	70283975
SVP4000 forend 24 U6	70283976
SVP6000 forend 24 U6	70283977
SVP2000 forend 24 U6	70283978
SVP2000F forend 24 U6	70283979
SVZ6000 forend 24 U6	70283980
SVA5000 forend 24 U6	70283981
SVA4000 forend 24 U6	70283982
SVA6000 forend 24 U6	70283983
SVA2000 forend 24 U6	70283984
SVA2000F forend 24 U6	70283985

**SVx U-striking plate**

**Article no.**

U-Shaped striking plate for SVP and SVI lock series, material: stainless steel, including 2 plastic end caps

SVP/SVZ/SVA striking plate 24 U5 x 24 x 232 mm	70283997
SVP/SVZ/SVA striking plate 24 U5,5 x 24 x 232 mm	70283998
SVI5000 striking plate 24 U4,2 x 24 x 310 mm	70284001
SVI4000 striking plate 24 U4,2 x 24 x 310 mm	70284002
SVI2000F striking plate 24 U4,2 x 24 x 380 mm	70284003



**SVx flat forend centre NEW**

**Article no.**

for SVx series locks, material: stainless steel, including screws for mounting with SVx NG full-leaf locks. F3 x 20 x 235 centre

SVP 5000 flat forend F3 x 20 centre	70285000
SVP 4000 flat forend F3 x 20 centre	70285001
SVP 6000 flat forend F3 x 20 centre	70285002
SVP 2000 flat forend F3 x 20 centre	70285003
SVP 2000 F flat forend F3 x 20 centre	70285004
SVZ 6000 flat forend F3 x 20 centre	70285005
SVA 5000 flat forend F3 x 20 centre	70285006
SVA 4000 flat forend F3 x 20 centre	70285007
SVA 6000 flat forend F3 x 20 centre	70285008
SVA 2000 flat forend F3 x 20 centre	70285009
SVA 2000 F flat forend F3 x 20 centre	70285010

## Rod lock system for SVI locks

### SVI set

Accessories required for installing SVI locks and drive deadbolts.  
Contains: bottom deadbolt guide plate, mounting aid lock/drive deadbolt, dormakaba torque tool, switch lock and top frame strike plate.

	Article no.
<b>01 SVI set 20mm</b> Installation on rebate doors with angle strike plate. 20 mm top frame strike plate.	70010291
<b>SVI set 24mm</b> Installation on non-rebated or narrow stile doors with lipped or flat strike plates. 24 mm top frame strike plate	70010290

### Drive deadbolt set

Drive deadbolt set consisting of top and bottom drive deadbolts.  
Used in connection with SVI locks.

	Article no.
<b>02 SVI TRS 25</b> Drive deadbolt set for doors up to 2.5 m	70932305
<b>SVI TRS 35</b> Drive deadbolt set for doors up to 3.5 m	70932306

### Ground keeper

Ground keeper for locking device of the bottom drive dead bolt on the passive door leaf. Required for emergency exit devices according to EN 1125.

	Article no.
<b>03 PHA 2122-0 (0 mm)</b>	3501421220000
<b>PHA 2122-2 (-2 mm)</b>	3501421222000
<b>PHA 2122-4 (-4 mm)</b>	3501421224000
<b>04 PHA 2121 +/-2</b> Flexible ground keeper. Flexibly adjustable (+/- 2 mm)	3501421210000

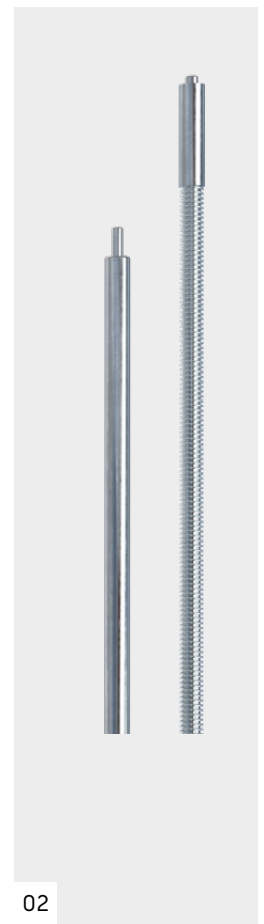
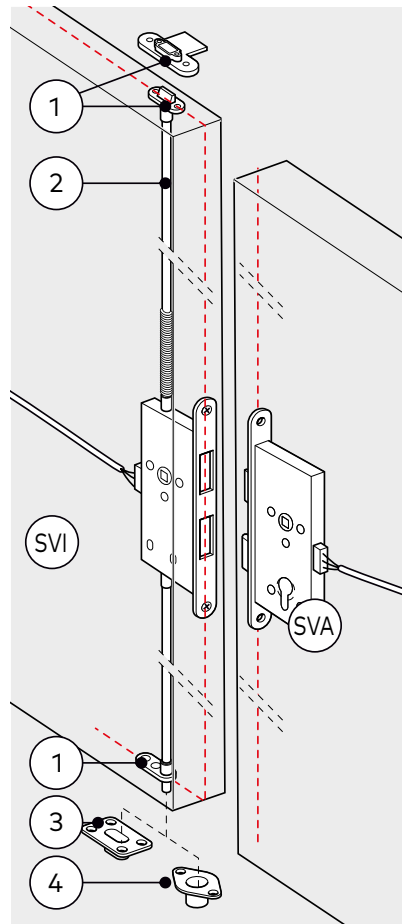

02

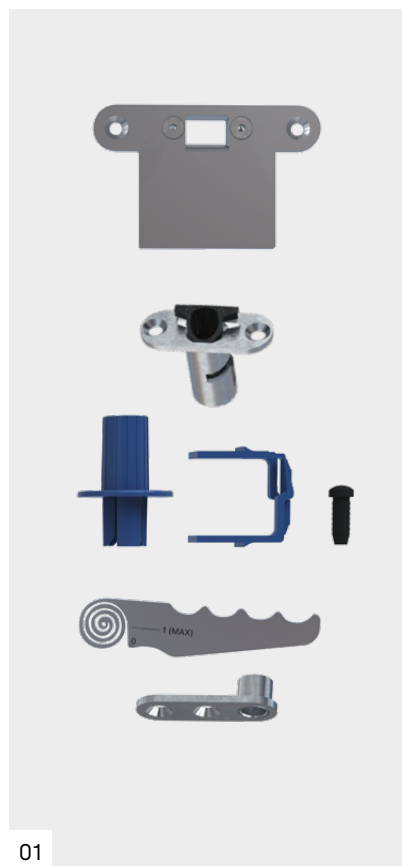

01



03



04



**TK Reed door contact** (not shown)

**Article no.**

Reed door contact for exclusive installation in wooden doors or for inlet installations (VdS no. G 191518, grade B), dimensions (Ø x T) approx.: 6 x 30 mm

**TK 103** brown 49931103  
**TK 110** white 49931110

Reed door contact for installation in wooden and metal doors, screw-on installation (VdS no. 191523, grade B), Dimensions (W x H x D) approx. 55 x 10 x 10 mm

**TK 203** brown 49931203  
**TK 210** white 49931210

**Article no.**

**M-SVP RK lock switch contact**

15198001

VDS class C no. G119 034 with a potential-free changeover contact for monitoring the locking of doors. For example, for integration of an alarm system or a building management system. Version specially adapted to M-SVP locks. With spacer plate for use with U-shaped striking plates. Not suitable for use with SVP.

Protection class: IP 67  
 Connection cable: LIYY 3 x 0,14 mm<sup>2</sup>, 6m  
 Switching capacity: 30 V DC, 1 A

**RK lock switch contact**

15198000

VDS class C no. G103 079 with a potential-free changeover contact for monitoring the locking of doors. For example, for integration of an alarm system or a building management system. Version specially adapted to SVP locks!

Protection class: IP 68,  
 Connection cable: 6 m LIYY 3 x 0,14 mm<sup>2</sup>,  
 Switching capacity: 30 V DC, 200 mA



**Accessories for SVP 7xxx Air**

**Article no.**

**SVP-S Air -I/O Box 12V-24V DC** (not shown)

70790000

SVP-S Air for controlling the battery-operated radio lock SVP 7000 Air, for installation in standard flush-mounted sockets. 2 inputs for short-term and long-term unlocking and 2 outputs for the status queries "Activity" and "Low battery level". Connection: 12-24 V DC

**SVP Air transmitter**

70790100

SVP Air transmitter/hand-held transmitter activates the battery operated SVP 7000 Air radio lock. The transmitter can be programmed in 1 separate or on multiple radio battery locks.

## SVP-S – Motor lock control units

dormakaba motor lock control units are used to control motor locks of the SSVP/SVA, SVP/SVA/SVI 2000 F and M-SVP 2200 series. In addition to a number of integrated functions, the control unit serves as an interface between the lock and the building control system, which, for example, allows for the output of status information or the integration of the system into an already existing IP (LAN) or LON network. The control units are available in various housing options – some with a power supply unit.

### **F** Note

With motor locks, the PERMANENTLY OPEN function must not be used for fire and smoke doors, as the blocking lever of the door is not available during a fire.

If used on fire and smoke doors, the SVP/SVA/SVI 2000 F variant with integrated power reserve module should be used. Use of at least 1 additional power reserve module is absolutely necessary.

### Comparison of SVP-S control units

Usage		Usable motor lock control unit			
		None	SVP-S3x (CH)	SVP-S4x	Direct via DCW®
Basic function only, no additional functions	SVP/SVA/SVI 2000/2000 F	●	–	–	–
	M-SVP 2200 DCW®	●	–	–	–
Full functional range, stand-alone unit	SVP/SVA/SVI 2000 F	–	●	●	–
	M-SVP 2200 DCW®	–	●	●	–
Can be integrated into networks (LON or LAN)	SVP/SVA/SVI 2000 F	–	–	●	–
	M-SVP 2200 DCW®	–	–	●	–
Configuration via TMS Soft	SVP/SVA/SVI 2000 F	–	–	●	–
	M-SVP 2200 DCW®	–	–	●	–
Test power reserve module, also available integrated as SVP/SVA/SVI 2000 F	SVP/SVA/SVI 2000	–	●	●	●
	SVP-PR	–	●	●	●
	M-SVP 2200 DCW® M-SVP-PR DCW®	–	●	●	●
Connection to dormakaba DCW® components (TMS system or ED with DCW® interface)	SVP/SVA/SVI 2000/2000 F	●	–	–	●
	M-SVP 2200 DCW®	●	–	–	●

● Yes – No



**SVP-S 5x**

For operation of the self-locking panic motor locks SVP/SVA 4000, 6000, 2000 as well as 2000 F or M-SVP 2200, in stand-alone mode without connection to the SafeRoute system or ED 100/250 – with full functional range. Control for motorised unlocking of the door (SVx 2000/F) or engagement of the exterior handle (SVx 6000), e.g. via access control systems (provided by the customer), is preconfigured. The control unit is connected to the lock via the DCW® system bus. If required (for retrofit), the control unit can be networked via LAN/LON. Extended parameterisation, visualisation and use of access control functions are carried out via the integrated RS-232 interface/LAN/LON using TMS Software Basic/Pro (from version 5.0).

Inputs: activation of the motor lock for short-term or permanent door release, day latch function (M-SVP only), smoke detector, door contact.

Outputs can be parameterised via TMS Soft.

Outputs: "locked", "unlocked", "door closed", "handle operation", "cylinder contact", alarm "door open", "collective alarm", "PR module test".

Connection: 24 V DC  
 Peak starting current: 150 mA (SVP)/1,5 A (M-SVP)  
 Closed-circuit current: approx. 70 mA  
 Maximum load current: 24 V DC; 0.5 A inductive, 1 A resistive

	<b>Article no.</b>
<b>01 SVP-S 53</b> Installed in plastic housing, DIN rail mounting, IP 54. Housing dimensions (W x H x D): approx. 202 x 152 x 90 mm / 9 TE	70922053
<b>02 SVP-S 54</b> Installed in plastic housing, DIN rail mounting, IP 54, with power supply unit NT 24 XS 2.5. Connection: 230 V AC +/-10 %. Housing dimensions (W x H x D): approx. 254 x 180 x 90 mm / 12 TE	70922054
<b>03 SVP-S 55</b> Installed in metal housing with tamper contact, prepared for emergency power supply using rechargeable battery pack AP 12 V (max. 2 units) and cable set (both to be ordered separately), IP 30, with USV-24. Connection: 230 V AC +/-10 %. Housing dimensions (W x H x D): approx. 305 x 130 x 380 mm / 2 x 15 TE	70922055
<b>04 SVP-S 56</b> For DIN rail mounting. Housing dimensions (W x H x D): approx. 125 x 95 x 60 mm / 7 TE	70922056

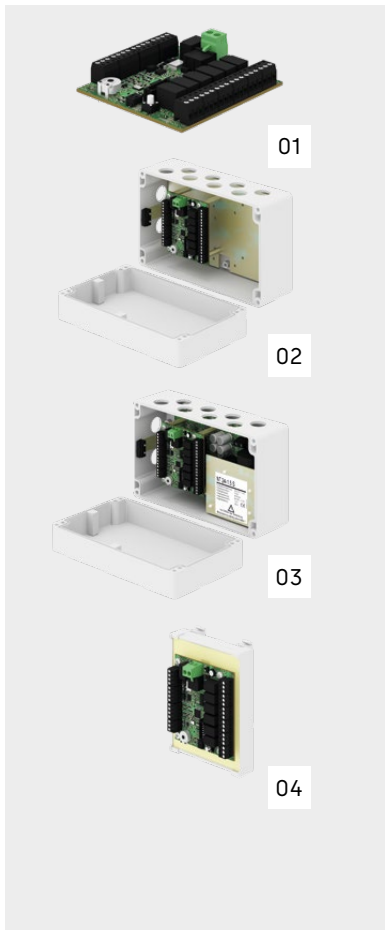

**SVP-S 3x DCW® LON** (not available for Germany)

SVP-S 3x DCW® control unit for operation of SVP 2000 DCW®, SVP 2000 DCW® F or M-SVP 2200 DCW® panic motor locks with automatic locking action in stand-alone operating mode with full functionality. This control unit offers various inputs and outputs, no software configuration required.

Configured for motorised locking and unlocking of the door via access control systems (on-site); control unit and lock are connected via the DCW® system bus. Inputs: activation of the motor lock for short-term or permanent door release, latch locking during day function (only M-SVP), smoke detector, door contact (only SVP). Outputs (potential-free): locked, unlocked, door closed, handle operated, cylinder contact, trigger, door opening alarm.

	<b>Article no.</b>
<b>01 SVP-S 32 DCW®</b> Supply for installation in switch cabinets and as replacement/extension. PCB dimensions (W x H x D): approx. 75 x 79 x 15 mm	70922032
<b>02 SVP-S 33 DCW®</b> Installed in plastic housing, IP 40. Housing dimensions (W x H x D): approx. 200 x 120 x 90 mm	70922033
<b>03 SVP-S 34 DCW®</b> Installed in plastic housing, IP 54, with NT 24-1.5S power supply unit. Connection: 230 V AC +/-10%. Housing dimensions (W x H x D): approx. 200 x 120 x 90 mm	70922034
<b>04 SVP-S 36 DCW®</b> For top hat rail installation Dimensions (W x H x D): 160 x 105 x 82 mm	70922036

**Note**

When connecting SVI motorised 2000 F locks to the S3x and S4x control units, one of the additional I/O modules is required for the full number of feedback signals from the inactive leaf lock.



**I/O modules**

	<b>Article no.</b>
<b>DCW® I/O module®</b> Bus coupling module for connecting products with analogue switching contacts to the dormakaba DCW® system bus. Four optocoupler inputs (activation with 5-30 V AC/DC signals) for external control. Four potential-free outputs for the control of external components or for signalling. Pre-parameterised addresses for various requirements. Individual requirements can be freely programmed using the TMS Soft parameterisation software (switch-on delay, switch-off delay, pulse, etc.). Connection loads: Supply voltage via DCW® bus Power consumption max. 45 mA Optocoupler inputs: U <sub>in</sub> , 5V/2,8 mA, 12 V/8 mA, 24 V/17 mA, 30 V/28 mA Relay outputs: 24 V DC/1 A Recommended cable: 1-4 (ST) Y 2 x 2 x 0,6 mm	56350100

<b>SIO-DR I/O module</b> I/O module for installation on to EN 50022 on TS35 top hat rail. <b>6 division units.</b> Bus coupling module for connecting devices with analogue wiring technology to SafeRoute via the dormakaba DCW® system bus. Additional module with four optocoupler inputs and four potential-free outputs. Voltage supply via DCW® bus, power consumption quiescent current 6 mA, relay active max. 51 mA, power consumption of the inputs at 5 V-28 V AC/DC: 5 V/3 mA; 12 V/8 mA; 24 V/17 mA; 28 V/28 mA per input, max. current load per output 1 A, dimensions (W x H x D) 106 x 92 x 65 mm/6 DU, for installation in housing or switch cabinet of at least IP30, ambient temperature -10 °C to +55 °C.	56450001
---	----------

**Usable from SLI standard**

## Narrow stile door fitting combinations\* approved to EN 1125

### Individual door or active door leaf lock

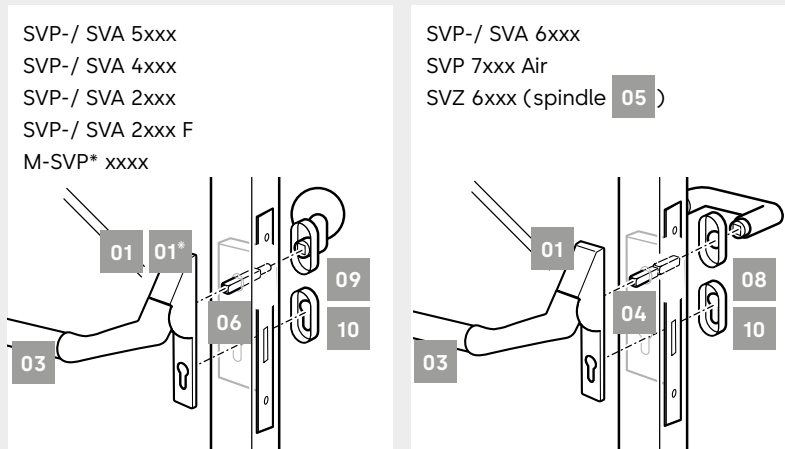

### Passive door leaf lock

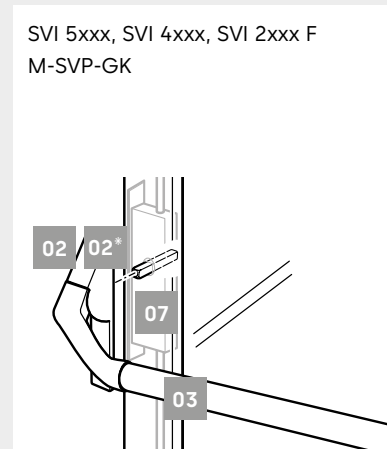

### PHA 2501 / 2540

Tested according to EN 1125 with dormakaba emergency-escape locks. Door widths up to 1,300 mm, door height up to 2,500 mm, standard bar projection <= 100 mm according to EN 1125 grade 1, jam-free, no visible mounting screws. Suitable for the use of europrofile cylinders (PC) and knob cylinders up to a diameter of 36 mm. Silver-coloured.

	<b>Order no.</b>
<b>01 PHA 2501 RR</b> Panic door fitting without push bar, can be used on narrow stile doors with SVP, SVA and M-SVP locks, distance 92 mm.	3501445130101
<b>01* PHA 2540 RR</b> Panic door fitting without push bar, can be used on narrow stile doors with M-SVP 2200 locks, distance 92 mm.	3501445134001
<b>02 PHA 2501- PC0 (SVI)</b> Panic door fitting without push bar, can be used on passive door leaf of double-leaf timber or narrow stile doors with SVI lock. With blind cover, for use without cylinder, silver-coloured.	3501445150101
<b>02* PHA 2525</b> Panic door fitting without push bar, can be used on inactive leaf with M-SVP-GK inactive leaf locks.	3501445140101
<b>03 PHA 2105</b> 1,130 mm connecting/handle pushbar. Silver-coloured.	3501421050001



### FP spindles 9 x 9 mm

	<b>Order no.</b>
<b>04 PHS 5S</b> Split spindle, 9 mm square, consisting of inside part 9 x 9 x 38.5 mm and a set of outside parts 9 x 9 x 46 mm, 9 x 9 x 53 mm, 9 x 9 x 56.5 mm and 9 x 9 x 60 mm, for use with locks with split follower (SVA 6xxx, SVP 6xxx, SVP 7xxx Air) and PHA 2501	3501478630501
<b>05 four+ 908 spindle RR, 9 x 9 mm, for SVZ 6xxx in combination with four+ 112 lever handle set (EN 179)</b> For 35–48 mm door thickness, length 97 mm For 49–61 mm door thickness, length 110 mm For 62–75 mm door thickness, length 123 mm	71000608 71000609 71000628
<b>06 four+ 916 split spindle RR, 9 x 9 mm in combination with four+ 112/216 knob/lever set (EN 179)</b> For 35–50 mm door thickness, length 90 mm For 51–65 mm door thickness, length 105 mm For 66–80 mm door thickness, length 120 mm	71000629 71000630 71000631
<b>07 114FS spindle, 9 x 9 mm</b> For inactive leaf sets, 105 mm (individually cut to length)	90050052907

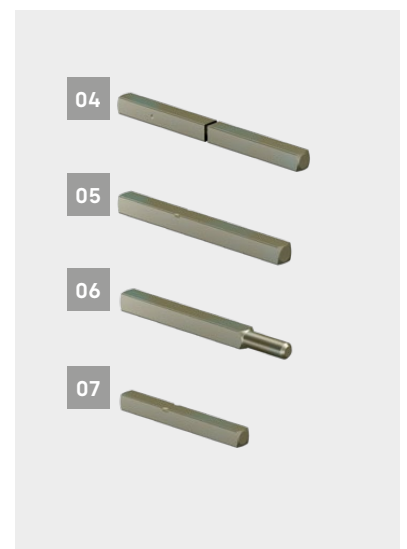

\* Recommendations apply to locks with profile cylinder PC and a distance A of 92 mm for narrow stile doors

# Narrow stile door fitting combinations\* approved to EN 179

## Individual door or active door leaf lock

SVP-/ SVA 5xxx  
SVP-/ SVA 4xxx  
SVP-/ SVA 2xxx  
SVP-/ SVA 2xxx F  
M-SVP\* xxxx

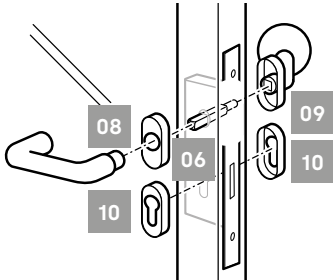

Alternative security fittings:  
SVP-SB 710

SVP-/ SVZ-/ SVA 6xxx  
SVP 7xxx Air  
SVZ 6xxx (spindle 05 )

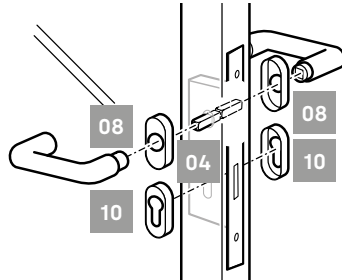

Alternative security fittings:  
SVP-SB 711

## Passive door leaf lock

SVI 5xxx, SVI 4xxx, SVI 2xxx F  
M-SVP-GK

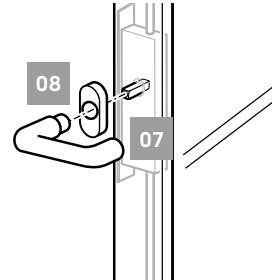

### four+ door fittings for tubular frame doors

suitable for fire doors in accordance with EN 1906-C1 and DIN 18273, L/R,  
matt stainless steel finish

**08 four+ 112 lever handle oval rosette**  
Half set, 9 mm, FS, EN 179, without spindle

**09 four+ 216 knob on oval rosette**  
Half set, without split spindle

**10 four+ 316 PZ oval rosette**  
with PZ profile punched

#### Order no.

71000603

71000604

71000605

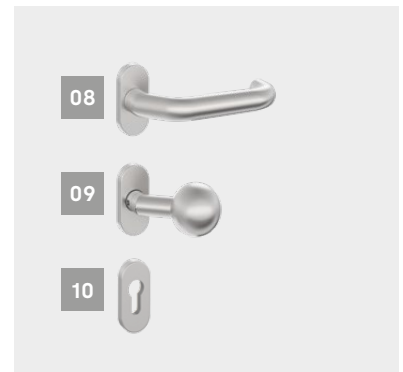

### Protective fittings for narrow stile doors

Protective fittings according to EN 179 and DIN 18257 ES 1 with anti-pull protection, certified for  
fire and emergency exit doors, cylinder projection 9–15 mm, distance 92 mm, anodised F1

**SVP-SB 710**  
Knob/lever set with short backplate for narrow stile doors with SVP/SVA 2xxx,  
SVP/SVA 2xxx F, SVP/SVA 4xxx, SVP/SVA 5xxx, for 44–57 mm door thickness, with  
9 mm spindle

**SVP-SB 711**  
Lever handle/lever set with short backplate for narrow stile doors with SVP/  
SVA 2xxx, SVP/SVA 2xxx F, SVP/SVA 4xxx, SVP/SVA 5xxx, for 54–75 mm door  
thickness, with split spindle

#### Order no.

49961001

49961101

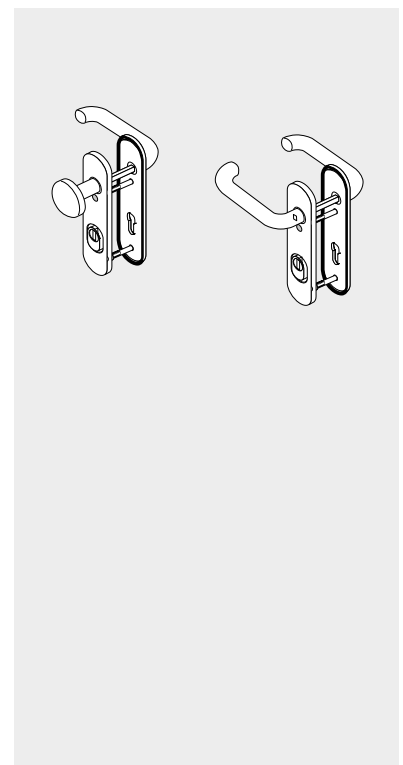

\* Recommendations apply to locks with profile cylinder PC and  
a distance A of 92 mm for narrow stile doors

## Timber door fitting combinations\* approved to EN 1125

### Individual door or active door leaf lock

SVP-/ SVA 5xxx  
SVP-/ SVA 4xxx  
SVP-/ SVA 2xxx  
SVP-/ SVA 2xxx F  
M-SVP\* xxxx

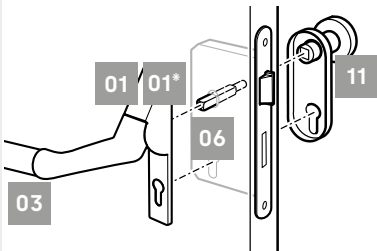

SVP-/ SVA 6xxx  
SVP 7xxx Air  
SVZ 6xxx (spindle 06 )

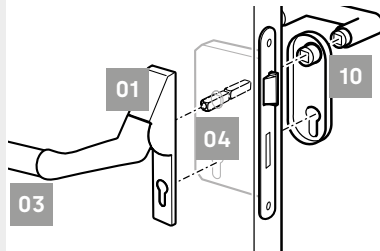

### Passive door leaf lock

SVI 5xxx, SVI 4xxx, SVI 2xxx F  
M-SVP-GK

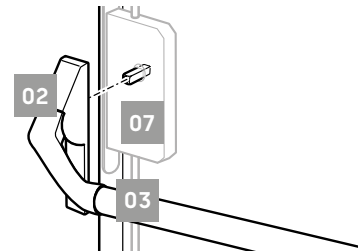

### PHA 2501

Tested according to EN 1125 with dormakaba emergency-escape locks. Door widths up to 1,300 mm, door height up to 2,500 mm, standard bar projection <= 100 mm according to EN 1125 grade 1, jam-free, no visible mounting screws. Suitable for the use of europrofile cylinders (PC) and knob cylinders up to a diameter of 36 mm. Silver-coloured.

	<b>Order no.</b>
<b>01 PHA 2501 VB</b> Panic door fitting without push bar, can be used on timber doors with SVP, SVA and M-SVP locks, distance 72 mm.	3501446230101
<b>01* PHA 2540 VB</b> Panic door fitting without push bar, can be used on timber doors with M-SVP 2200 locks, distance 72 mm.	3501446234001
<b>02 PHA 2501- PC0 (SVI)</b> Panic door fitting without push bar, can be used on passive door leaf of double-leaf timber or narrow stile doors with SVI lock. With blind covering, to be used without cylinder. Silver-coloured.	3501445150101
<b>02* PHA 2525</b> Panic door fitting without push bar, can be used on inactive leaf with M-SVP-GK inactive leaf locks.	3501445140101
<b>03 PHA 2105</b> 1,130 mm connecting/handle pushbar. Silver-coloured.	3501421050001

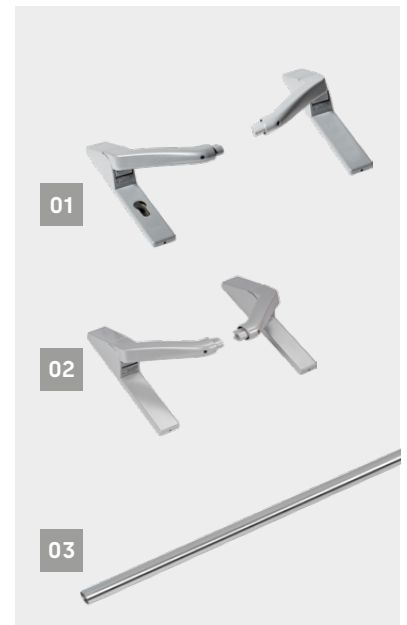

### FP spindles 9 x 9 mm

	<b>Order no.</b>
<b>04 PHS 5S</b> Split spindle, 9 mm square, consisting of inside part 9 x 9 x 38.5 mm and a set of outside parts 9 x 9 x 46 mm, 9 x 9 x 53 mm, 9 x 9 x 56.5 mm and 9 x 9 x 60 mm, for use with locks with split follower (SVA 6xxx, SVP 6xxx, SVP 7xxx Air) and PHA 2501	3501478630501
<b>05 four+ 904 spindle VB, 9 x 9 x 116 mm, for SVZ 6xxx</b> For 64–72 mm door thickness in combination with four+ 104 lever set (EN 179)	71000614
<b>06 four+ 912 split spindle VB, 9 x 9 x 105 mm</b> for 64–72 mm door thickness in combination with four+ 104/204 knob/lever set (EN 179)	71000616
<b>07 split spindle 114FS, 9x9 mm</b> For inactive leaf sets, 105 mm (individually cut to length)	90050052907

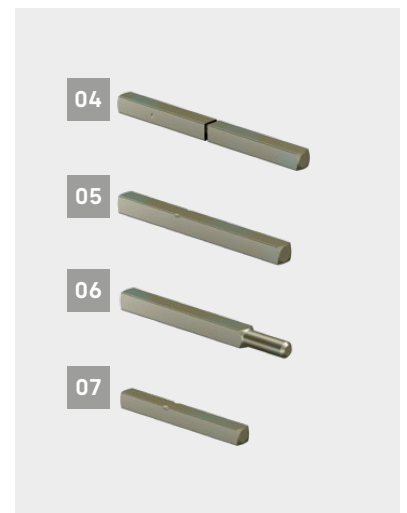

\* Recommendations apply to locks with profile cylinder PC and a distance A of 72 mm for timber doors

# Timber door fitting combinations\* approved to EN 179

## Individual door or active door leaf lock

SVP-/ SVA 5xxx  
SVP-/ SVA 4xxx  
SVP-/ SVA 2xxx  
SVP-/ SVA 2xxx F  
M-SVP\* xxxx

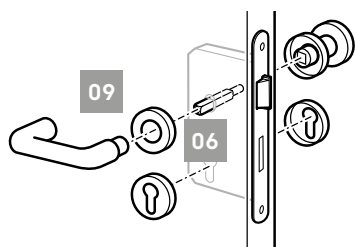

Alternative security fittings:  
SVP-SI 310 or SVP-SI 210

SVP-/ SVA 6xxx  
SVP 7xxx Air  
SVZ 6xxx (spindle 06 )

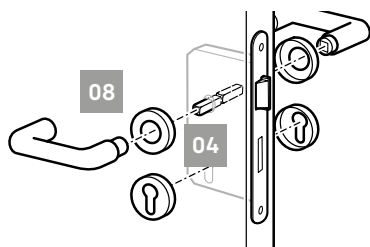

Alternative security fittings:  
SVP-SI 311 or SVP-SI 211

## Passive door leaf lock

SVI 5xxx, SVI 4xxx, SVI 2xxx F  
M-SVP-GK

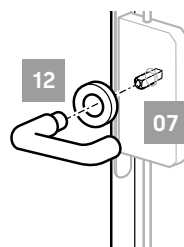

### four+ door fittings for timber doors

suitable for fire doors in accordance with EN 1906-C1 and DIN 18273, L/R,  
matt stainless steel finish

	<b>Order no.</b>
<b>08 four+ 104/104 lever set on round roses</b> PZ profile punched, 9 mm, EN 179, for door thickness 38–63 mm, including spindle	71000003
<b>09 four+ 104/204 lever set on round rosette</b> PZ profile punched, 9 mm, EN 179, for door thickness 38–63 mm, including split spindle	71000005
<b>10 four+ 104 lever handle on short backplate</b> PZ profile punched, 9 mm, threaded side, without spindle	71000120
<b>11 four+ 204 knob on short backplate</b> PZ profile punched, 9 mm, threaded side, without split spindle	71000130
<b>12 four+ 104 lever handle on round rosette</b> 9 mm, EN 179, passage side, without spindle	71000105
<b>13 four+ 204 knob on round rosette</b> VB, DG, ER matt	71000110
<b>14 PZ round rosette, punched</b> DG, ER matt	71000100

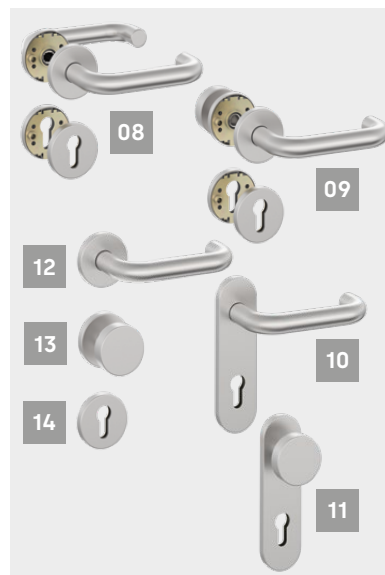

### Protective fittings for timber doors

Protective fittings according to EN 179 and DIN 18257 ES 1 with anti-pull protection, certified  
for fire and emergency exit doors, cylinder projection 9–15 mm, distance 72 mm, stainless steel

	<b>Order no.</b>
<b>SVP-SI 210</b> Knob/lever set with long backplate for timber doors with SVP/SVA 2xxx, 2xxx F, 4xxx, 5xxx, for 36–50 mm door thickness, with 9 mm spindle	70921004
<b>SVP-SI 211</b> Lever handle/lever handle set with long backplate for timber doors with SVP/SVA/SVZ 6xxx, SVP 7xxx Air, for 40–50 mm door thickness, with split 9 mm spindle	70921104
<b>SVP-SI 310</b> Lever handle/lever handle set with short backplate for timber doors with SVP/SVA 2xxx, 2xxx F, 4xxx, 5xxx, for 64–74 mm door thickness, with 9 mm spindle	70931004
<b>SVP-SI 311</b> Lever handle/lever handle set with short backplate for timber doors with SVP/SVA/SVZ 6xxx, SVP 7xxx Air, for 68–74 mm door thickness, with split 9 mm spindle	70931104

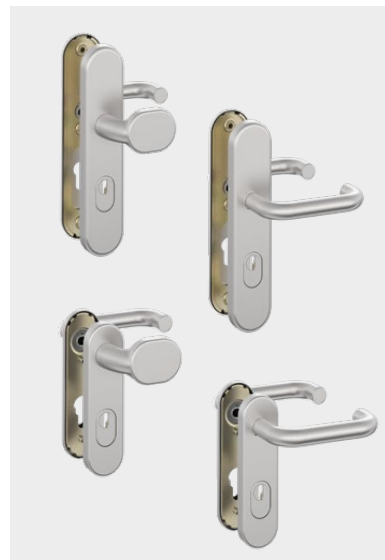

## Example EN 1125 door solution Double-leaf purely mechanical door system

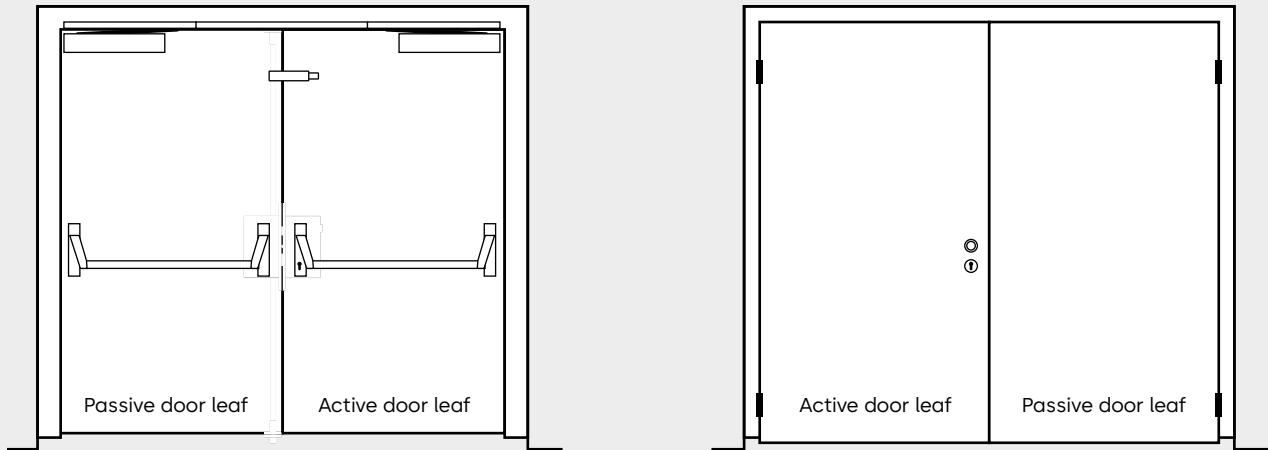

- The door can always be opened from inside
- The door lock is locked automatically when the door is closed
- From the outside, the door lock on the active door leaf can be opened with the key

Active door leaf equipment	Page
<b>Lock</b>	
- SVA 5xxx	19
<b>Door fittings</b>	
- PHA 2501 VB or RR with PHA 2105 pushbar	83
- OGRO CORE knob with OGRO 115 FP pin	84
<b>Door closer</b>	See brochure
- TS 98 XEA	TS 98 XEA
<b>Passive door leaf equipment</b>	
<b>Lock</b>	
- SVI 5xxx	55
- SVI set	78
- Drive deadbolt set	78
- Ground keeper	78
<b>Door fittings</b>	
- PHA 2501- PC0 (SVI) with PHA 2105 pushbar	83
- OGRO 127 FP pin	83
<b>Door closer</b>	See brochure
- TS 98 BG XEA	TS 98 XEA
- GSR XEA slide channel	
- Carry bar	
(required for use in fire and smoke doors)	

## Example EN 1125 and EN 13637 door solution Double-leaf door system in an escape route

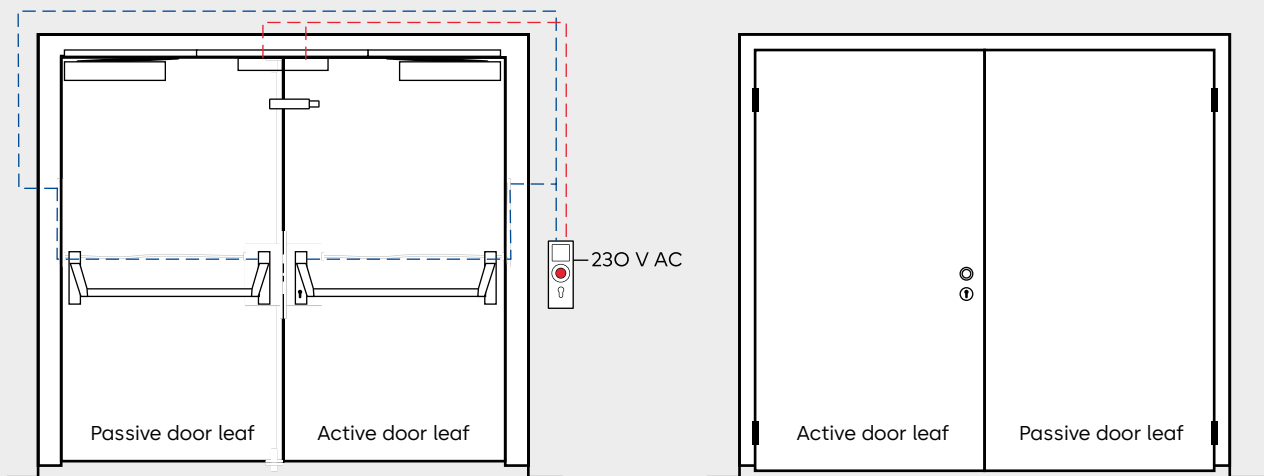

- From the inside, the door can be opened by pressing the emergency button
- The door lock is locked automatically when the door is closed
- From the outside, the door lock on the active door leaf can be opened with the key
- Monitoring and control of the door and lock status is carried out via the control room

Active door leaf equipment	Page
<b>Lock</b>	
- SVA 4xxx with monitoring functions	21
- SVP-A 1100 connection cable	75
- Cable loop	76
<b>Door fittings</b>	
- PHA 2501 VB or RR with PHA 2105 pushbar	83
- OGRO CORE knob with OGRO 115 FP pin	84
<b>Door closer</b>	See brochure
- TS 98 XEA	TS 98 XEA
<b>STV 200</b>	See brochure
- Electromechanical door locking device	SafeRoute
<b>Passive door leaf equipment</b>	
<b>Lock</b>	
- SVI 4xxx with monitoring functions	56
- SVP-A 1100 connection cable	75
- Cable loop	76
- SVI set	78
- Drive deadbolt set	78
- Ground keeper	78
<b>Door fittings</b>	
- PHA 2501- PC0 (SVI) with PHA 2105 pushbar	83
- OGRO 127 FP pin	83
<b>Door closer</b>	See brochure
- TS 98 BG XEA	TS 98 XEA
- GSR XEA slide channel	
- Carry bar	
(required for use in fire and smoke doors)	
<b>STV 200</b>	See brochure
- Electromechanical door locking device	SafeRoute
<b>Control and monitoring centre</b>	
<b>SafeRoute STL-G NT terminal</b>	See brochure
with Basic licence card	SafeRoute

## Example EN 1125 door solution Double-leaf door system with electronic release

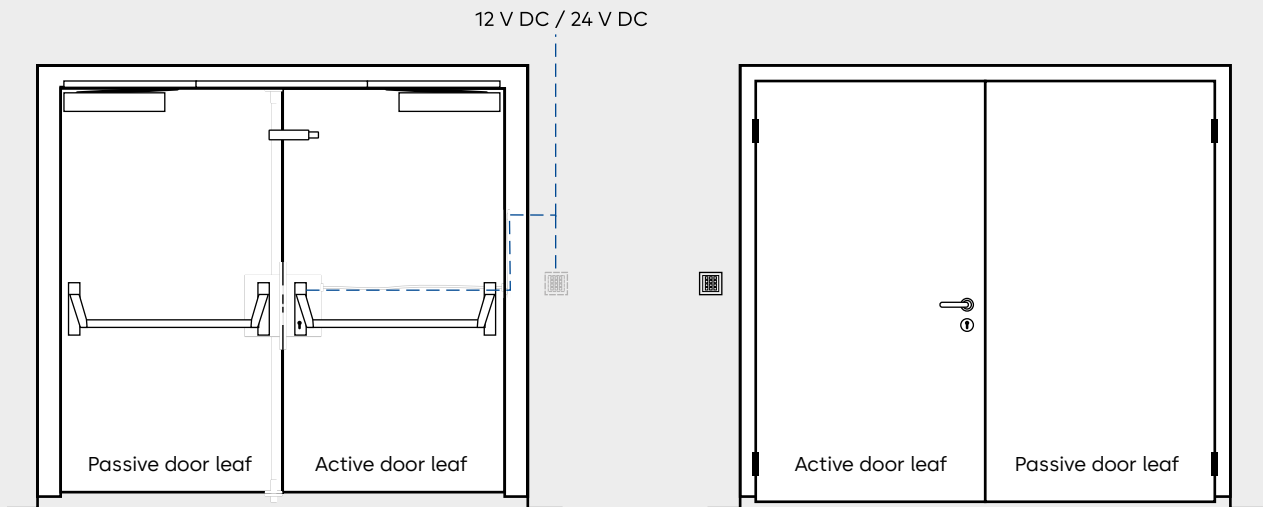

- The door can always be opened from inside
- The door lock is locked automatically when the door is closed
- From the outside, the door lock on the active door leaf can be opened with the key or with an electric access control system

Active door leaf equipment	Page
<b>Lock</b>	
- SVA 6xxx	23
- SVP-A 1100 connection cable	75
- Cable loop	76
<b>Door fittings</b>	
- PHA 2501 VB or RR with PHA 2105 pushbar	83
- OGRO lever handle with OGRO 120 FP pin	84
<b>Door closer</b>	See brochure
- TS 98 XEA	TS 98 XEA
<b>Passive door leaf equipment</b>	
<b>Lock</b>	
- SVI 5xxx	55
- SVI set	78
- Drive deadbolt set	78
- Ground keeper	78
<b>Door fittings</b>	
- PHA 2501- PC0 (SVI) with PHA 2105 pushbar	83
- OGRO 127 FP pin	83
<b>Door closer</b>	See brochure
- TS 98 BG XEA	TS 98 XEA
- GSR XEA slide channel	
- Carry bar	
(required for use in fire and smoke doors)	
<b>Control unit</b>	
<b>Access control system with analogue NO/NC switch contacts</b>	
e.g. card reader and PIN code	

## Example EN 1125 door solution

### Double-leaf automatic door system with electronic release

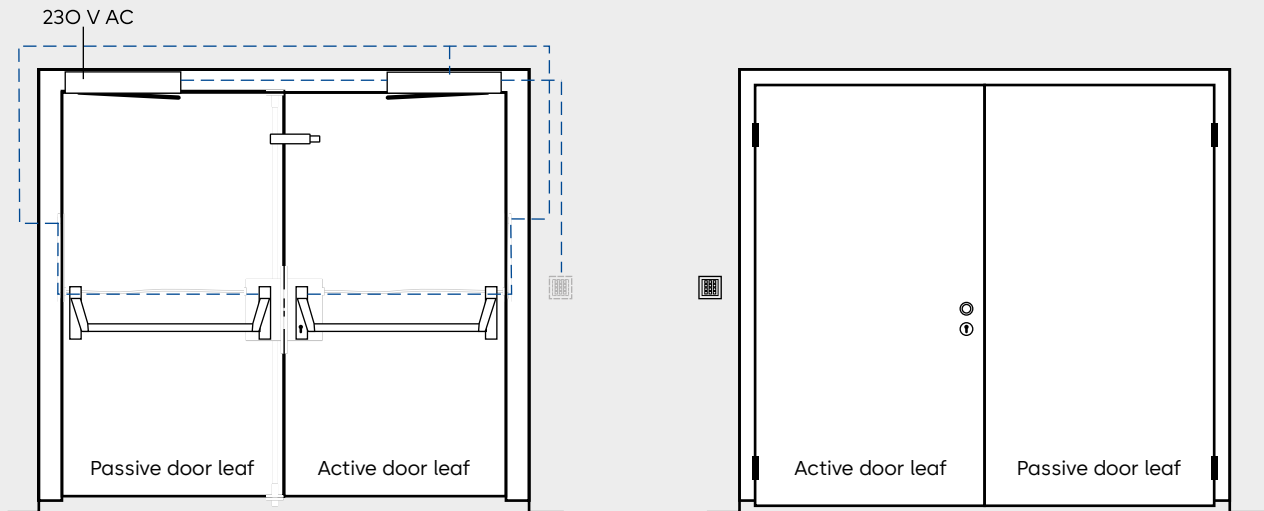

- From the inside, the door can be opened by pressing the emergency button
- The door lock is locked automatically when the door is closed
- From the outside, the door can be opened with the key, with an electric access control system or switch, both door leaves open automatically

Active door leaf equipment	Page
<b>Lock</b>	
- SVA 2xxx F motor lock	33
- SVP-A 1100 connection cable	75
- Cable loop	76
<b>Door fittings</b>	
- PHA 2501 VB or RR with PHA 2105 pushbar	83
- OGRO CORE knob with OGRO 115 FP pin	84
<b>Swing door operator</b>	
- ED 100/ED 200 (equipment depending on the type of door)	See brochure ED 100
<b>Passive door leaf equipment</b>	
<b>Lock</b>	
- SVI 2xxx motor lock	57
- SVP-A 1100 connection cable	75
- Cable loop	76
- SVI set	78
- Drive deadbolt set	78
- Ground keeper	78
<b>Door fittings</b>	
- PHA 2501- PC0 (SVI) with PHA 2105 pushbar	83
- OGRO 127 FP pin	83
<b>Swing door operator</b>	
- ED 100/ED 200 (equipment depending on the type of door)	See brochure ED 100
<b>Control unit</b>	
<b>Access control system with analogue NO/NC switch contacts</b> e.g. card reader and PIN code	



## Our Sustainability Commitment

We are committed to foster a sustainable development along our entire value chain in line with our economic, environmental and social responsibilities toward current and future generations.

At dormakaba, we are dedicated to find sustainable solutions that reduce the environmental impact of both our operations and our products. To ensure transparency regarding our products' environmental impacts, we offer credentials such as Environmental Product Declarations (EPD), Health Product Declarations (HPD), and Recycled Content Certificates. These sustainability-related credentials provide insights into energy efficiency, material composition, recyclability, and compliance, empowering our customers to make informed choices and support their own sustainability objectives.

Download our sustainability-related product declarations and certifications here: <https://www.dormakabagroup.com/en/sustainability/product-declarations>



## Our offering

### Access Automation Solutions

Entrance Automation  
Entrance Security



### Access Control Solutions

Electronic Access & Data  
Escape and Rescue Systems  
Lodging Systems



### Access Hardware Solutions

Door Closers  
Architectural Hardware  
Mechanical Key Systems



### Services

Technical Support  
Installation and commissioning  
Maintenance and Repair



WN 05460851532, EN, 05/2026  
Subject to technical modifications.



[dormakaba.com](https://www.dormakaba.com)

**dormakaba**  
**International Holding AG**  
Hofwissenstrasse 24  
CH-8153 Rümlang  
T +41 44 818 90 11  
[info@dormakaba.com](mailto:info@dormakaba.com)  
**dormakaba.com**