

Funeo wireless smoke detection system for smoke detection panels on door-locking systems



Screw on the ceiling smoke detector and manual release button, connect the wireless module to the smoke detector with integrated power pack, and it's ready to go. No need to lay expensive cables on the ceiling and in the wall. Not only is the Funeo wireless smoke detection system easy to install, it also has an impressive and functional design. A discreet light ring indicates the operating status and its long battery life guarantees an operating time of up to 8 years.

A neat and simple solution for installers and facility operators.

- 01 Funeo wireless smoke detector dormakaba RM-F
- 02 Funeo wireless module dormakaba FM-AP
- 03 Funeo wireless manual release button dormakaba

How you benefit:

- Almost wireless installation of a smoke detection system
- Tried-and-tested security; meets legal requirements for fire and smoke doors
- Connects up to 20 wireless nodes in a network
- Each wireless node extends the wireless range (repeater function)
- Built-in battery for up to 8 years of operation
- LED light ring informs about the operating status
- Easy, quick and cost-effective to install

Wireless smoke detection system with innovative LED light ring. Safe to operate, easy to install.

The Funeo wireless smoke detection system consists of the FM-AP wireless module, the RM-F smoke detector and the optional HT-F wireless manual release button for surface-mounted and flush-mounted applications. The wireless module is connected to the smoke detector with integrated power pack. All components are equipped with a multi-colour LED display. During standard operation, the LED indicator lights up green when the door is opened. In the event of malfunctions, the colour changes to yellow or red, e.g. when there are dust deposits in the smoke detector, a weak battery or when the statutory operating time has been reached. In service mode and during commissioning, additional colour codes support efficient setup and regulatory maintenance.

01 Funeo RM-F wireless smoke detector. The RM-F wireless smoke detector with a multi-coloured LED light ring reliably detects smouldering fires as well as open fires with smoke development.

02 Funeo FM-AP wireless module. The FM-AP wireless module with a multi-coloured LED light ring is connected to the RMZ smoke detector with integrated power pack and serves as a receiver for the RM-F wireless smoke detectors and HT-F wireless manual release button. Up to 20 wireless nodes can be registered. The module comes in white and silver as standard. Special colours are also available on request.

03 FM-AP Console. Mounting console for the FM-AP radio module

04 Funeo HT-F wireless manual release button. The HT-F wireless manual release button supplements the system with manual triggering of the wireless smoke detection system. A multi-coloured LED lamp provides information about the operating status. The push button is supplied with a surface-mounted socket but can also be installed in a flush-mounted socket with a depth of at least 50 mm.

Data and features – Wireless smoke detection system

Frequency band	SDR	
Frequency ranges and transmitting power	433.05 – 434.79 MHz 865.0 – 868.6 MHz	10 dBm / 10 mW 14 dBm / 25 mW
Encryption	AES256	
Range within the building	0.3 m – 20 m	
RM-F operating principle	Diffused light	
Smoke threshold	in accordance with EN 54-7	
Operating voltage RM-F and HT-F	3 V DC	
Battery life of RM-F and HT-F	Battery must be replaced after approx. 8 years.	
FM AP operating voltage	18 – 28 V DC	
Max. power input	13 mA	
FM AP relay	Switching voltage Switching current (permanent) Switching current (max. 200 µs) Switching power	max. 30 V DC max. 2 A DC max. 10 A DC max. 60 W
Operating and storage temperature	-30 °C to 70 °C	
Ambient conditions, humidity (continuous, without condensation) at ≤ 34 °C	10 ... 95% RH	
Degree of protection	IP 42 (RM-F), IP 40 (FM-AP), IP 20 (HT-F)	
Conformity	RED (2014/53/EU), RoHS (2011/65/EU)	

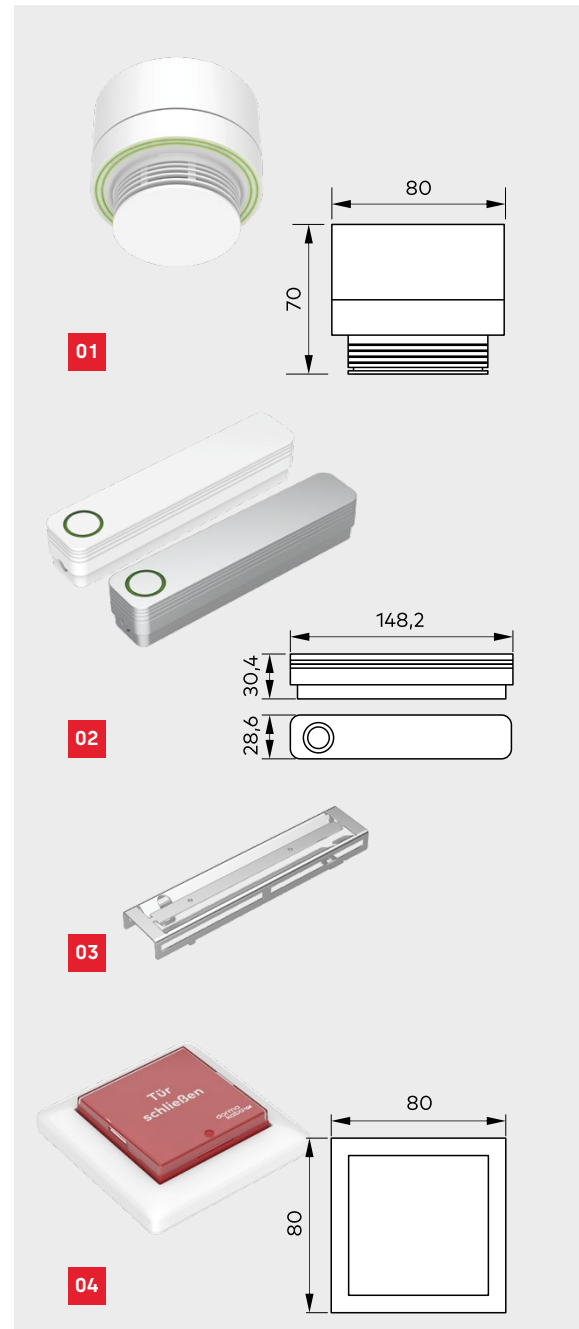

F Certificate of suitability

As a supplement to the dormakaba RMZ smoke detector with integrated power pack, the wireless smoke detection system has been approved for general use in buildings by the German Institute for Civil Engineering (DIBt), Berlin. An acceptance test and regular maintenance are required.

Any questions? We would be happy to advise you.

Contact us on: +41 44 818 90 11