

ST and TST

Automatic Sliding Door Systems





Sliding doors from dormakaba - the right solution for your building. Elegant, sustainable, secure. Automatic sliding doors offer convenience and security for every building.

Depending on requirements, with or without escape route function, with burglary protection, as a telescopic version and as an energy-saving variant.

Overview of the product variants		4-9	
Planning		10	
Door panel systems	ST Sliding doors (Profile)	ST PRO Green	12
		ST PRO Green RC2 with above-floor routing	14
		ST PRO Green RC2 / RC3	16
		ST FLEX	18
		ST FLEX Green	20
	ST All-glass sliding doors	ST PURE	22
		ST MANET	24
	TST Telescopic sliding doors	TST FLEX	26
		TST FLEX Green	28
	Additions	Operator casings (incl. suspension)	30
		Protective wings	31
		Georgian bar profiles	32
		Underfloor routing	32
		Floor locks	33
Electrical interlocking		33	
Electromotive hook locking device		34	
Operators ES PROLINE	Variants	35	
	Features and auxiliary equipment	36	
	Master controller functions and expansion modules	37	
	Technical Data	38	
Operating elements	Connections	40	
	dormakaba Door Pilot App	41	
	Program switches	42	
	Switches	43	
	Emergency activation buttons	45	
	Active infrared detectors and combined sensors	46	



01

Automatic sliding doors

ST and TST – a suitable solution for every requirement

The architectural and functional requirements of an automatic door system are numerous. The extensive product range from dormakaba meets every requirement. The durable Direct Drive motor technology ensures quiet and long-lasting operation. Thanks to the wide range of product options and the modular design, every individual requirement can be realised economically.

Individually adaptable and modular drive technology

The basis of every sliding door system is always an operator from the ES PROLINE series. The functions of the sliding door system result from the selected operator and can be configured as required. In combination with one of our sliding door systems, we offer a suitable solution in proven quality.

Safe operation as standard

All systems comply with the safety standards EN 16005 and DIN 18650. Safety sensors are required for touch-free protection of the door leaves. The required safety measures result from the respective risk analysis.

Increased burglary protection if required

Secure locking is provided by the operator or manually on request. In addition, the resistance class (up to RC3) can be achieved with some sliding door systems by means of electric motor-driven locks and further reinforcements.



Escape routes

The special requirements in escape routes are fulfilled by all systems that are equipped with an Series ES PROLINE FST operator.



02



03



04



05

Large range of sliding door and telescopic sliding door systems

From the thermally separated door leaf profile to the elegant all-glass sliding door system, dormakaba offers a multitude of sliding door systems. Together with an operator from the the ES PROLINE series, you will find the optimum solution for your application.

A wide range of design options

All ST sliding door systems and TST telescopic sliding door systems can be flexibly planned and can be supplemented with side panels, fanlights and, if required, additional protective wings.

Seamless integration into façade systems

Many sliding door systems can be convincingly integrated into a wide variety of façade systems. The possibilities are manifold.

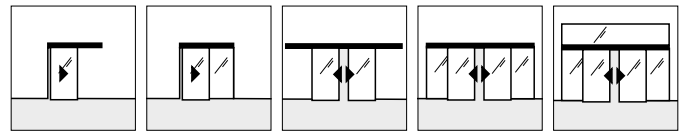

Sliding door systems ST

- ST PRO Green: Thermally insulated profile system
- ST PRO Green RCx: Thermally insulated profile system with increased burglary resistance class RC2 or RC3
- ST FLEX: Slim profile system
- ST FLEX Green: Slim profile system with improved thermal separation
- ST PURE: All-glass with point fixings
- ST MANET: All-glass with stainless steel brackets

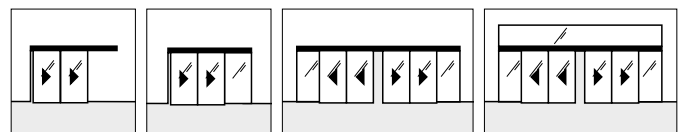

Telescopic sliding door systems TST

- TST FLEX: Slim profile system
- TST FLEX Green: Slim profile system with improved thermal separation

- 01 ST PRO Green
- 02 ST PURE All-glass sliding door system
- 03 ST FLEX Green sliding door system, one-sided opening
- 04 ST FLEX Sliding door system as escape route door, opening on one side with operator integrated in the suspended ceiling
- 05 TST FLEX Telescopic sliding door system integrated in facade

Which sliding door system fits to your requirements?

Whether a noble façade design is continued with corresponding door systems or accents are set in the entrance area: Automatic sliding doors leave almost nothing to be desired.

Depending on the requirements, the sliding door system is composed of a sliding door system (profile system or all-glass) and an operator from the ES PROLINE series.

Profile systems		ST Sliding doors				Telescopic sliding doors	
		ST Pro Green	ST Pro Green RC2 / RC3	ST FLEX	ST FLEX Green	TST FLEX	TST FLEX Green
Thermal insulation	ISO glass double	○	○	○	●	○	●
	ISO glass triple	●	●	-	○	-	○
	Improved thermal separation	-	-	-	●	-	●
	Thermally separated profile	●	●	-	-	-	-
Suitable for wind-exposed sites		○	●	○	○	○	○
Burglary protection	RC-Glass	○	●	○	○	○	○
	Floor lock	○	○	○	○	○	○
	hook locking (multipoint)	○	●	○	○	-	-
	Unterfloor rail	○	●	○	○	○	○
Profile view (ca. -Dimensions)	horizontal (top)	50 mm	50 mm	47 mm	47 mm	47 mm	47 mm
	vertical	50 mm	77 mm	35 mm	46 mm	35 mm	46 mm
Emergency exit approval		○	○	○	○	○	○
Possible clearance dimensions*	LW	700 – 3,000 mm		700 – 3,000 mm		800 – 4,000 mm	
	LH	2,050 – 3,000 mm		2,000 – 3,000 mm		2,000 – 3,000 mm	

All-glass systems

		ST Pure	ST Manet	
Emergency exit approval		○	○	● standard ○ optional - no
Possible clearance dimensions*	LW	700 – 2,000 mm	700 – 2,000 mm	
	LH	2,000 – 2,500 mm	2,000 – 2,500 mm	

* The concrete maximum dimensions that can be executed result from the respective door planning (e.g. glass type/door leaf weight, door leaf format (height to width), wind load conditions in the object, floor guide, etc.) and the door requirements.

ST PRO Green

The sliding door ST PRO Green is characterised by excellent thermal properties. In combination with double or triple glazing, particularly low UD values (heat transfer coefficient) of up to 1.0 can be achieved (value depends on the glass used and the door size). The door thus fulfils the strict requirements of the current Building Energy Act GEG (formerly EnEV). A very high stability of the door elements is also achieved through the optimised profile cross-sections with low-torsion webs. The sustainability of the door is certified by an Environmental Product Declaration (EPD).

Areas of application: Exterior doors with high demands on thermal insulation and/or wind-exposed positions (with additional continuous floor rail).

Detail see page 12



ST PRO Green RC2 / RC3

The sliding doors ST PRO Green RC2 / RC3 have similarly excellent thermal properties as the ST PRO Green. In addition, the doors guarantee a high level of protection against burglary and vandalism thanks to a locking system and other constructive measures. A continuous floor guide is standard with this system. The sliding door system is RC2 or RC3 tested and certified. The sustainability of the door is certified by an Environmental Product Declaration (EPD).

Areas of application: Exterior doors with high thermal insulation requirements, thermal insulation, wind-exposed locations and increased need for burglary protection.

Detail see page 16



ST FLEX

The ST FLEX sliding door can be used universally due to the small profile face widths. The high number of different construction types enables the optimal solution of demanding object requirements. Sliding doors with telescopic drive are available with the same profile system. Optionally, single-pane glazing or also insulating glazing can be used.

Areas of application: Exterior doors with insulating glazing, wind trap solutions, interior doors as room closures in public buildings, sales rooms, etc.

Detail see page 18



ST FLEX Green

The ST FLEX Green sliding door is an energy-saving sliding door, specially designed for external building closure. The profiles with improved thermal separation result in very good insulation values. Even the most unfavourable sizes still meet the strict requirements of the current Building Energy Act GEG (formerly EnEV). The thermal transmittance coefficients UD are proven by test certificates. The sustainability of the door is certified by an Environmental Product Declaration (EPD). Due to the slim profile elevations, this door type can be combined very well with the other door systems from the FLEX family.

Areas of application: Especially for exterior doors and wind trap solutions, closures in public buildings of all kinds.

Detail see page 20



All-glass systems

ST all-glass sliding door systems are frameless door systems made of glass. This creates light-flooded and barrier-free entrance solutions in the interior of buildings.

ST PURE



The ST PURE sliding door is a "real" all-glass door whose door leaves are held exclusively by point holders. The holders with a clear angular design language are painted silver and give the door leaves a discreet appearance. The door versions with or without side panels or with skylights provide a friendly and open atmosphere in the interior of the building.

Areas of application: Interior doors as room closures e.g. in office buildings, medical practices, hotels, restaurants, sales rooms or passageways. Detail see page 22

ST MANET



The ST MANET system is ideal for particularly high-quality commercial applications. The point holders of this door are made of solid, high-quality stainless steel. Here, as well, door versions are available with or without side panels or with or without fanlight.

Areas of application: High-quality interior fittings, as room closures e.g. in law firms, medical practices and hotels.

Detail see page 24

Telescopic sliding door systems TST

TST telescopic sliding door systems offer a larger passage width than simple sliding door systems with the same overall width. Especially when the structural openings are not sufficiently dimensioned, telescopic sliding door systems offer a good alternative.

TST FLEX



The TST FLEX telescopic sliding door is based on the same profile system as the ST FLEX sliding doors. The small profile face widths make the door appear very transparent overall. Other door types from the FLEX family can be combined very harmoniously in a building. The door leaves are glazed with ISO 22 mm insulating glass.

Areas of application: External or internal doors, wind trap solutions in public buildings, sales rooms, etc.

Detail see page 26

TST FLEX Green



The TST FLEX Green telescopic sliding door is based on the same profile system as the ST FLEX Green sliding doors and is also an energy-saving sliding door specially designed for external building closure. The profiles have improved thermal separation and the thermal transmittance coefficients UD are proven by test certificates. Due to the slim profile elevations, this door type can be combined very well with the other door systems from the FLEX family.

Areas of application: Especially for exterior doors and wind trap solutions, closures in public buildings. Detail see page 28

System planning

You should know these dimensions

Drive, door leaf, side panels and fanlight

Single-opening sliding doors can be designed to open to the right or left. In addition, telescopic sliding doors are possible with the TST FLEX and TST FLEX Green profile system.

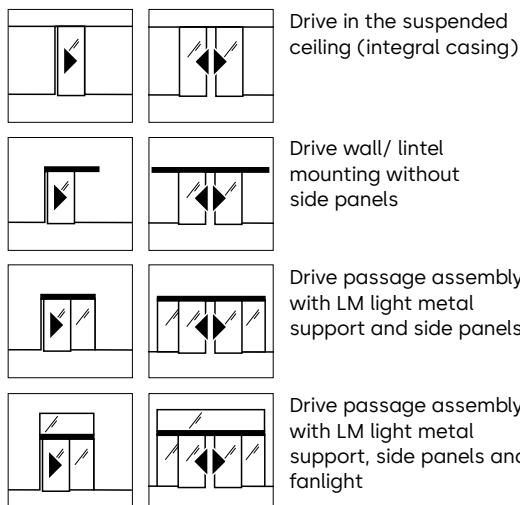

Individual sliding door system as standard

Each system is individually planned and produced. The modular approach of our systems ensures economical implementation. Each system can be easily extended with further automatic and access functions from the dormakaba range.

Freely selectable size and design

The dimensions of the sliding door systems are freely selectable. Depending on the sliding door system, the glass selected and the door leaf weight, passage widths of up to 3,000 mm are possible for sliding door systems and up to 4,000 mm for telescopic sliding door systems. The profile surfaces are anodised as standard or powder-coated according to the individual colour of common powder manufacturers. For special requirements, more resistant coatings are also possible, e.g. in swimming pool construction or near the coast.

Our service starts at the planning stage

We support every project at an early stage. The architectural and functional requirements are the starting point. Every sliding door system is delivered ready for installation. Installation, commissioning and maintenance are carried out by our qualified personnel. Comprehensive documentation in the local language is supplied with every system.

Maximum system dimensions

Depending on the sliding door system and the glass selected, the maximum system dimensions are limited by the weight of the TG door leaves. For more detailed information, please refer to the chapters on sliding door systems.

The following formula can be used to roughly determine the door leaf weight TG:

$$TG = \frac{LH [m] \times LW [m] \times \text{glass weight [kg/m}^2]}{\text{Number of door leaves}}$$

Common glass thicknesses and weights:

10 mm e.g. ESG 10: 25 kg/m²

12 mm e.g. ISO 22, 2 x VSG 6: 30 kg/m²

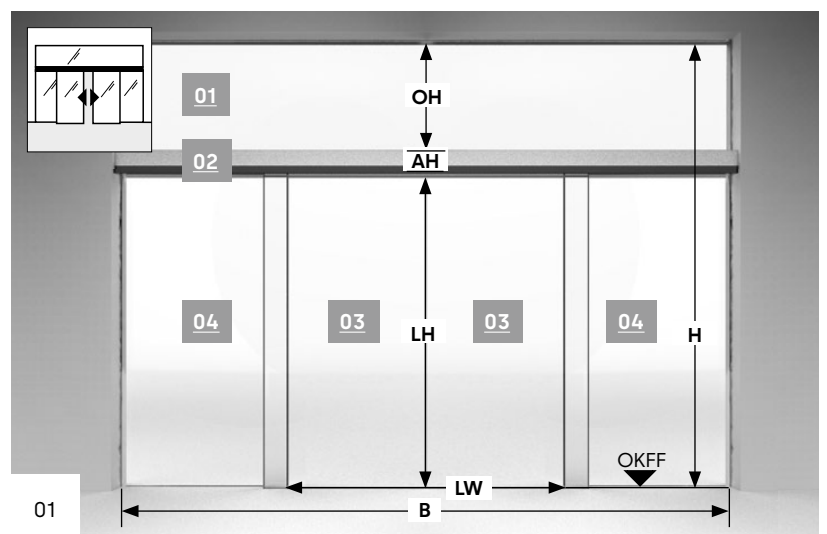

- 01** Fanlight
- 02** Drive unit
- 03** Sliding door panel
- 04** Stationary side screen

Opening to one side

Opening to both sides

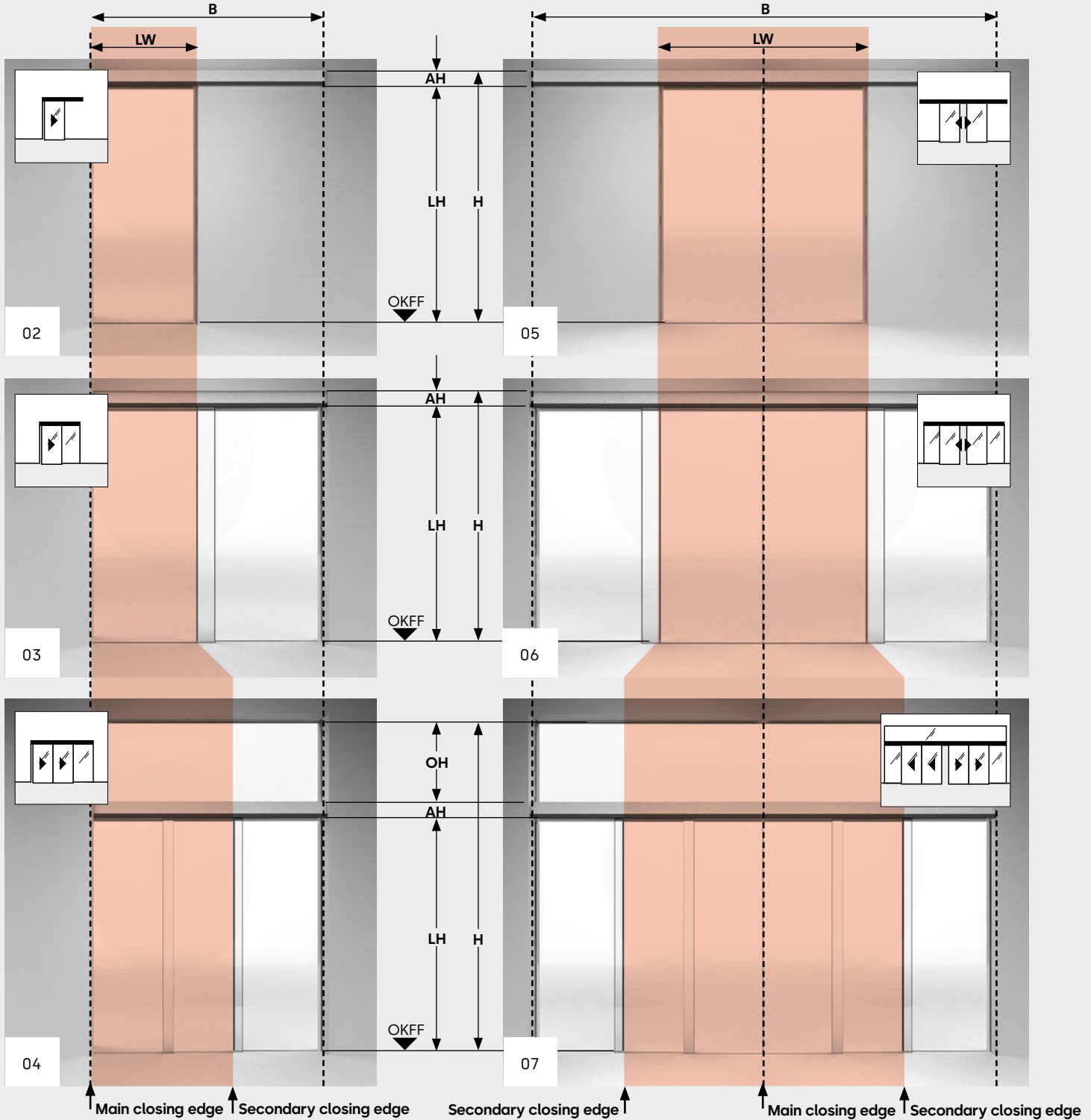

- LW:** Clearance width (passage width)
- LH:** Clearance height (passage width)
- B:** Total system width
- OH:** Height of fanlight (option)
- H:** Total system height
- AH:** Drive height 100 or 150 mm dependent on version
- OKFF:** Upper edge of finished floor

System examples

- 01** Sliding door opening on two sides with side panel and fanlight
- 02** Sliding door opening on one side
- 03** Sliding door opening on one side with side panel
- 04** Telescopic sliding door opening on one side with side panel and fanlight
- 05** Sliding door opening on two sides
- 06** Sliding door opening on two sides with side panel
- 07** Telescopic sliding door opening on two sides with side panel and fanlight

ST PRO Green

Thermally separated profile system

Properties

- Complies with the current German Building Energy ACT GEG (formerly EnEV)
- Particularly low U_D values up to 1.0 W/m²K calculated individually for each door system
- Minimised profile face widths
- Above-floor and underfloor routing possible
- Drive height 100 mm or 150 mm
- Certified thermal conductivity values to EN ISO 10077
- Environmental Product Declaration (EPD) included

Glazings

- Double glazing ISO 34 with warm edge
- Triple glazing ISO 50 with warm edge
- Special glazing



Possible additions

- Protective leaf in front of the moving leaf or in the façade
- Georgian bar profile (Availability on request)
- Underfloor routing
- Main closing edge with multi-point locking system (see variant RC2/RC3) (Availability on request)

Approximate determination of door leaf weight

$$T_G = \frac{LH [m] \times LW [m] \times \text{glass weight [kg/m}^2]}{\text{Number of door leaves}} + 7,5 \text{ kg}$$

Common glass weight for triple glazing: 45 kg/m²

		Version	ST PRO Green
Drive type		Standard	ES 250 PRO/ES 400 PRO
		Escape route 	ES 250 PRO FST/ES 400 PRO FST
Door parameters*			
System width (B) min. =	1-leaf	Passageway installation (without safety clearance, without post width)	2 x LW + 153 mm
		Wall mounting, without post width	2 x LW + 115 mm
	2-leaf	Passageway installation (without safety clearance)	2 x LW + 180 mm
		Wall mounting	2 x LW + 120 mm
Clearance width LW ²	1-leaf	Standard	700 – 3,000 mm
		Escape route 	700 – 3,000 mm
	2-leaf	Standard	800 – 3,000 mm
		Escape route 	800 – 3,000 mm
Max. door leaf weight	1-leaf	ES 250 PRO/ES 250 PRO FST	1 x 125 kg
		ES 400 PRO/ES 400 PRO FST	1 x 250 kg
	2-leaf	ES 250 PRO/ES 250 PRO FST	2 x 125 kg
		ES 400 PRO/ES 400 PRO FST	2 x 200 kg
Clear passage height LH*			2,050 – 3,100 mm



The requirements in escape routes are met by all systems that are equipped with an operator from the ES PROLINE FST series.

* The maximum practicable dimensions are subject to the respective door plans and door requirements and also depend on the profile system selected. For doors with tested anti-intruder protection, increased requirements are placed on the structural tolerances as well as the careful design of the structure.
² The minimum clearance width for escape route sliding doors is laid down in the respective regional building codes and may vary in certain circumstances.

Main closing edge variants

- LW:** Clearance width
- LH:** Clearance height
- B:** Total system width
- OH:** Skylight height (option)
- H:** Total system height
- AH:** Drive height 100 or 150 mm dependent on version
- OKFF:** Upper edge of finished floor prefabricated floor

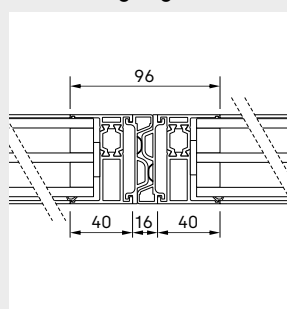

Opening to both sides

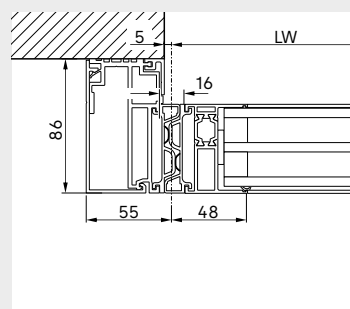

Lintel installation, opening to one side

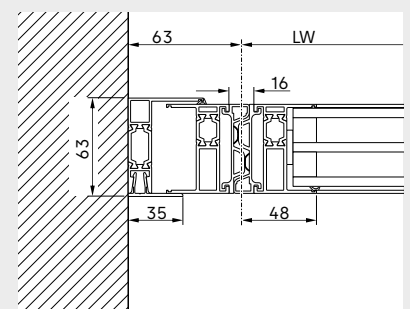

Passageway installation, opening to one side

Installation variations and drive casings

- 01** Sensor casing 100 mm
- 02** Integral casing overall height 100 mm
- 03** Standard casing 100 mm
- 04** Integral casing overall height 150 mm
- 05** Standard casing 150 mm

Note on installation with light metal beam

For doors with side panels and light metal beam, the drive must either be suspended or the 150 mm drive type is required for door leaf weights of approx. 125 kg or more – depending on the clearance width.

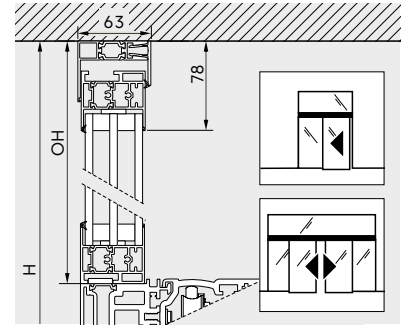

Installation in suspended ceiling

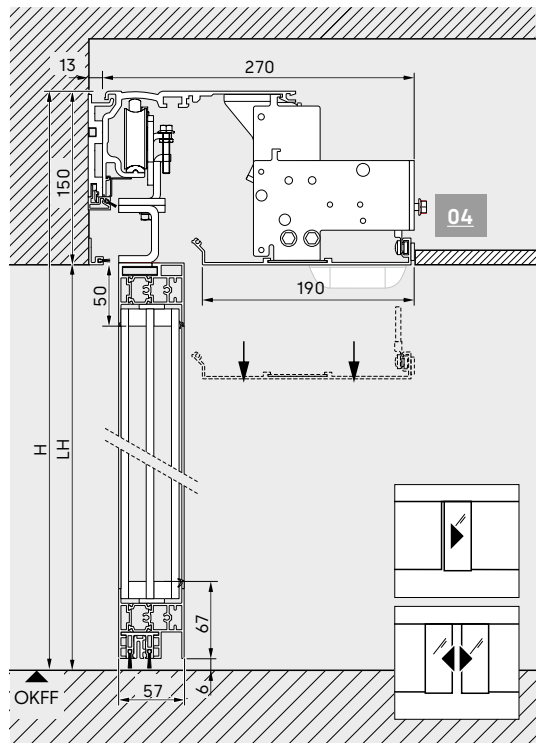
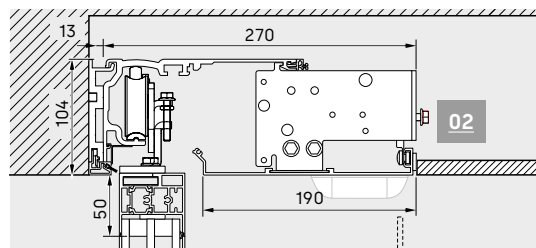

Wall/lintel installation

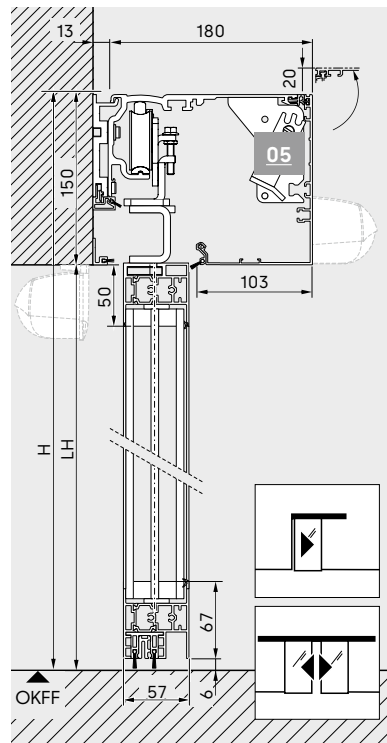
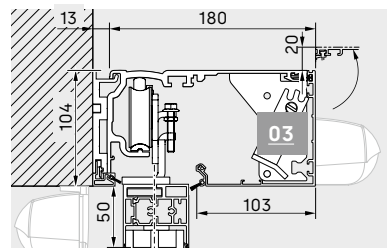
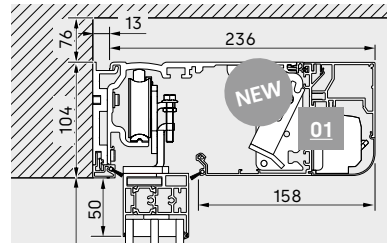

Installation with light metal beam

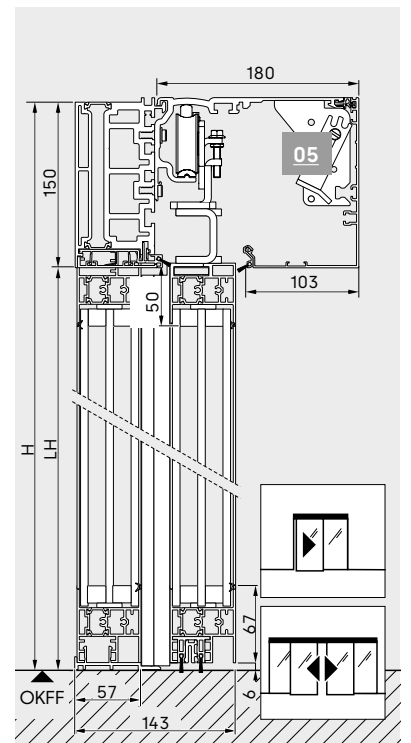
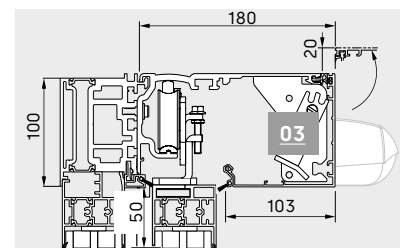
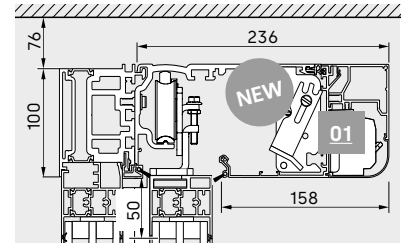

Secondary closing edge variants

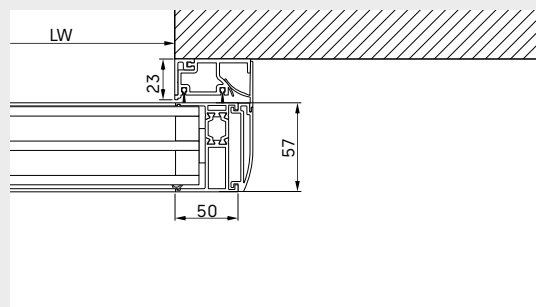

Lintel installation variant

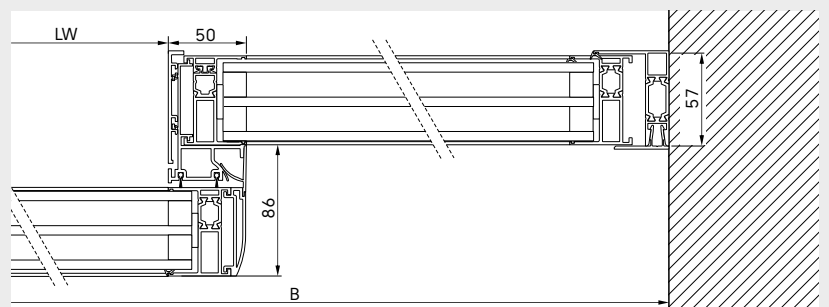

Variants with side panels

ST PRO Green RC2 with above-floor routing

Thermally separated profile system with certified burglary protection

Properties

- Complies with the current German Building Energy ACT GEG (formerly EnEV)
- Particularly low U_D values up to 1.0 W/m²K calculated individually for each door system
- Minimised profile face widths
- Certified burglary protection RC2 despite above-floor routing
- Multi-point locking system in the door leaf
- Overhead guidance for RC2 doors on request
- Drive height 100 mm
- Certified thermal conductivity values to EN ISO 10077
- Environmental Product Declaration (EPD) included

Glazings

- For resistance class RC2: P4A glazing
- Double glazing ISO 34 with warm edge
- Triple glazing ISO 50 with warm edge
- Special glazing

Possible additions

- Protective leaf in front of the moving leaf or in the façade
- Manual release (with manual release and optional protective leaf, the clearance width LW is reduced by 166 mm for 2-leaf systems and 83 mm for 1-leaf systems)
- For Switzerland: Manual, external hand release via Bowden cable to meet country-specific requirements

Approximate determination of door leaf weight

$$T_G = \frac{LH [m] \times LW [m] \times \text{glass weight [kg/m}^2]}{\text{Number of door leaves}} + 21.5 \text{ kg}$$

Common glass weight for burglar-resistant glazing (RC2/RC3):
Up to 59 kg/m²



The requirements in escape routes are met by all systems that are equipped with an operator from the ES PROLINE FST series.

		Version	ST PRO Green RC2
Drive type		Standard	ES 400 PRO
		Escape route	ES 250 PRO FST/ES 400 PRO FST
Door parameters*			
System width (B) min. =	1-leaf	Passageway installation (without safety clearance)	2 x LW + 233 mm
		Wall mounting	2 x LW + 227 mm
	2-leaf	Passageway installation (without safety clearance)	2 x LW + 207 mm
		Wall mounting	2 x LW + 207 mm
Clearance width LW ²	1-leaf	Standard	800 – 1,100 mm
		Escape route	800 – 1,100 mm
	2-leaf	Standard	1,000 – 1,900 mm
		Escape route	1,000 – 1,900 mm
Max. door leaf weight	1-leaf	ES 400 PRO/ES 400 PRO FST	1 x 250 kg
	2-leaf	ES 400 PRO/ES 400 PRO FST	2 x 200 kg
Clear passage height LH*			2,050 – 3,100 mm

* The maximum practicable dimensions are subject to the respective door plans and door requirements and also depend on the profile system selected. For doors with tested anti-intruder protection, increased requirements are placed on the structural tolerances as well as the careful design of the structure.

²The minimum clearance width for escape route sliding doors is laid down in the respective regional building codes and may vary in certain circumstances.

Main closing edge variants with multi-point locking system

- LW:** Clearance width
- LH:** Clearance height
- B:** Total system width
- OH:** Skylight height (option)
- H:** Total system height
- AH:** Drive height 100 or 150 mm dependent on version
- OKFF:** Upper edge of finished floor prefabricated floor

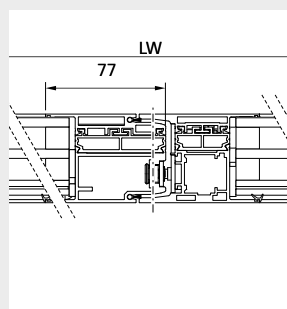

Opening to both sides

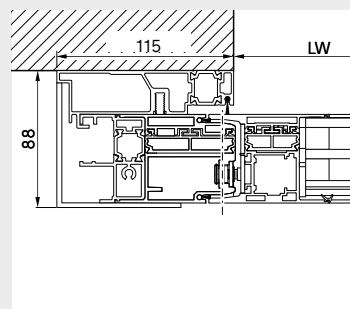

Lintel installation, opening to one side

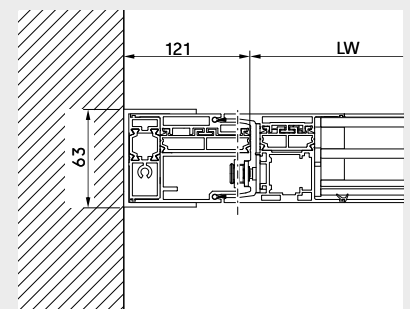

Passageway installation, opening to one side

Note on installation with light metal beam

For a total leaf weight over 2 x 125 kg, an additional suspension and/or the 150 mm drive type is required.

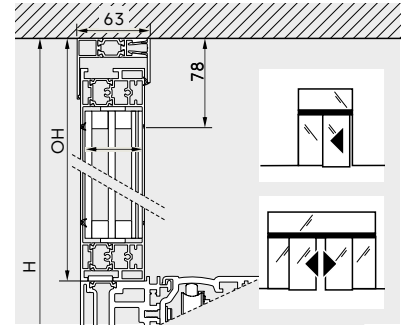

Installation variations and drive casings

- 01 Sensor casing 100 mm
- 02 Integral casing overall height 100 mm
- 03 Standard casing 100 mm
- 04 Integral casing overall height 150 mm
- 05 Standard casing 150 mm
- 06 Optional manual release

Wall/lintel installation

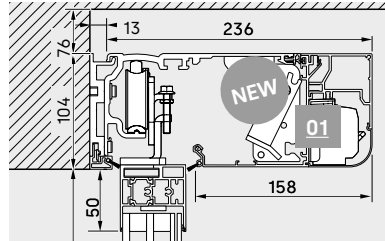

Installation with light metal beam

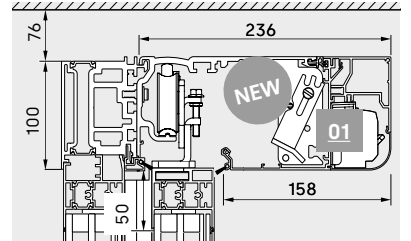

Installation in suspended ceiling

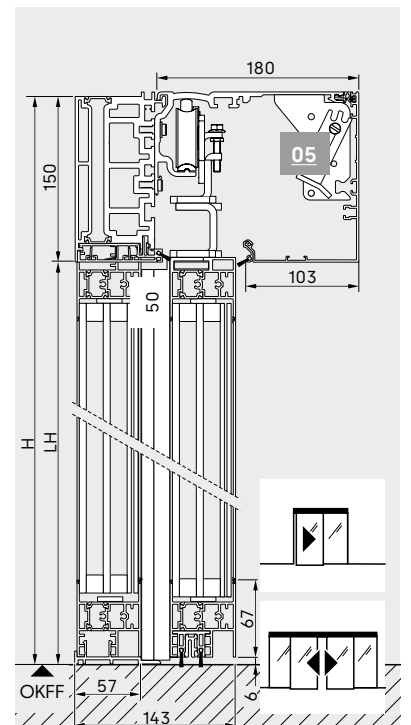
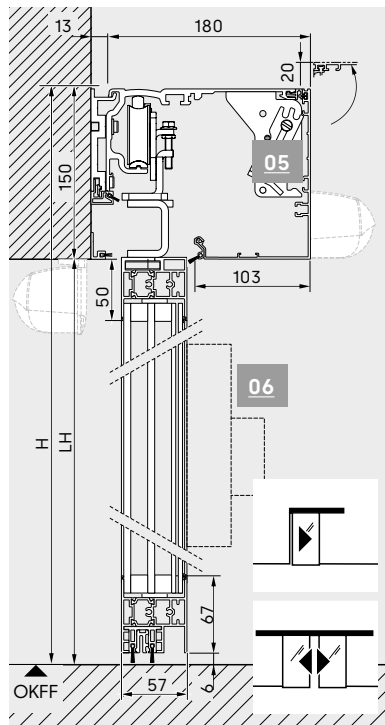
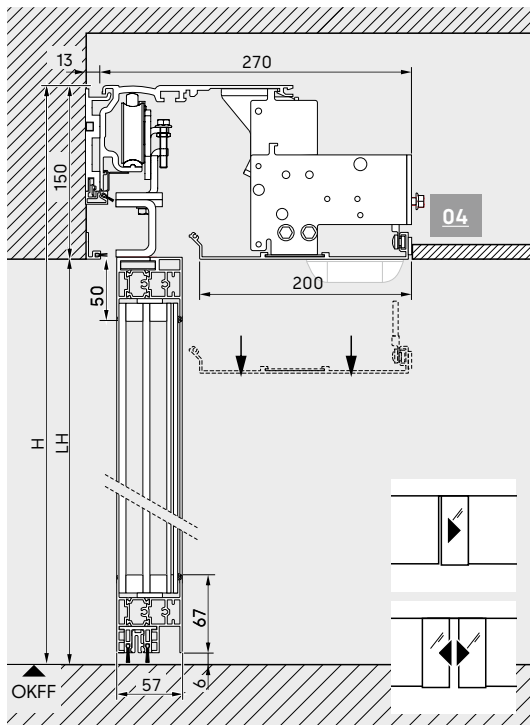
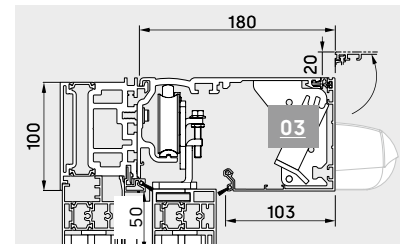
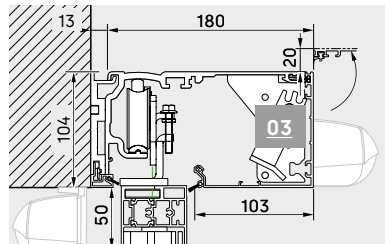
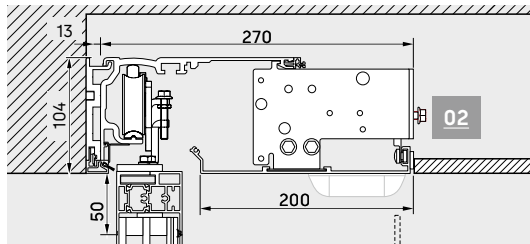

Secondary closing edge variants

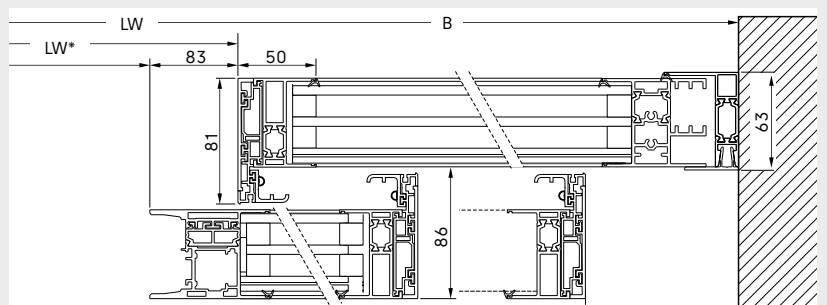
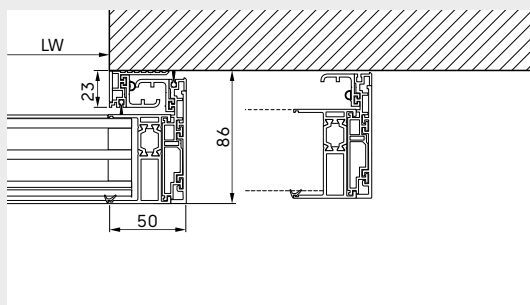

Lintel installation variant

Variants with side panels *with manual release (p. 34) and protective leaf (s. 31)

ST PRO Green RC2 / RC3

Thermally separated profile system with certified burglary protection

Properties

- Complies with the current German Building Energy ACT GEG (formerly EnEV)
- Particularly low U_D values up to 1.0 W/m²K calculated individually for each door system
- Minimised profile face widths
- Underfloor routing and pry-out protection as standard
- Multi-point locking system in the door leaf
- Overhead guidance for RC2 doors on request
- Drive height 100 mm
- Certified thermal conductivity values to EN ISO 10077
- Environmental Product Declaration (EPD) included

Glazings

- For resistance class RC2: P4A glazing
- For resistance class RC3: P5A glazing
- Double glazing ISO 34 with warm edge
- Triple glazing ISO 50 with warm edge
- Special glazing

Possible additions

- Protective leaf in front of the moving leaf or in the façade
- Manual release (with manual release and optional protective leaf, the clearance width LW is reduced by 166 mm for 2-leaf systems and 83 mm for 1-leaf systems)
- For Switzerland: Manual, external hand release via Bowden cable to meet country-specific requirements

Approximate determination of door leaf weight

$$T_G = \frac{LH [m] \times LW [m] \times \text{glass weight [kg/m}^2]}{\text{Number of door leaves}} + 21.5 \text{ kg}$$

Common glass weight for burglar-resistant glazing (RC2/RC3):
Up to 59 kg/m²



The requirements in escape routes are met by all systems that are equipped with an operator from the ES PROLINE FST series.

		Version	ST PRO Green RC2/RC3
Drive type		Standard	ES 400 PRO
		Escape route	ES 250 PRO FST/ES 400 PRO FST
Door parameters*			
System width (B) min. =	1-leaf	Passageway installation (without safety clearance)	2 x LW + 233 mm
		Wall mounting	2 x LW + 227 mm
	2-leaf	Passageway installation (without safety clearance)	2 x LW + 207 mm
		Wall mounting	2 x LW + 207 mm
Clearance width LW ²	1-leaf	Standard	800 – 3,000 mm
		Escape route	800 – 3,000 mm
	2-leaf	Standard	1,000 – 3,000 mm
		Escape route	1,000 – 3,000 mm
Max. door leaf weight	1-leaf	ES 400 PRO/ES 400 PRO FST	1 x 250 kg
	2-leaf	ES 400 PRO/ES 400 PRO FST	2 x 200 kg
Clear passage height LH*			2,050 – 3,100 mm

* The maximum practicable dimensions are subject to the respective door plans and door requirements and also depend on the profile system selected. For doors with tested anti-intruder protection, increased requirements are placed on the structural tolerances as well as the careful design of the structure.

²The minimum clearance width for escape route sliding doors is laid down in the respective regional building codes and may vary in certain circumstances.

Main closing edge variants with multi-point locking system

- LW:** Clearance width
- LH:** Clearance height
- B:** Total system width
- OH:** Skylight height (option)
- H:** Total system height
- AH:** Drive height 100 or 150 mm dependent on version
- OKFF:** Upper edge of finished floor prefabricated floor

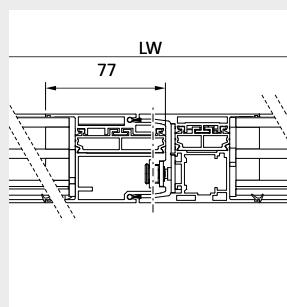

Opening to both sides

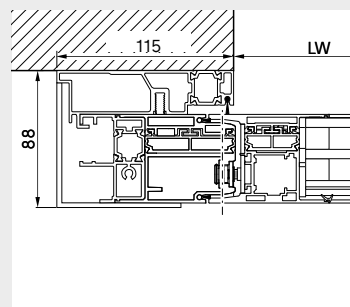

Lintel installation, opening to one side

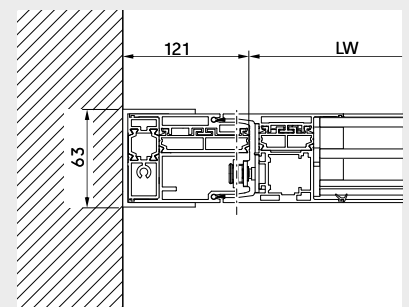

Passageway installation, opening to one side

Note on installation with light metal beam

For a total leaf weight over 2 x 125 kg, an additional suspension and/or the 150 mm drive type is required.

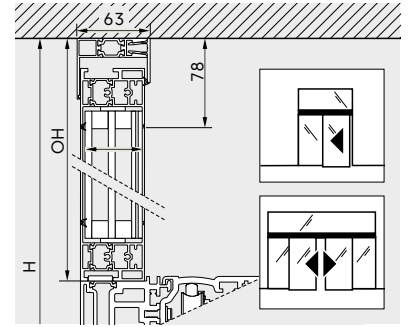

Installation variations and drive casings

- 01** Sensor casing 100 mm
- 02** Integral casing overall height 100 mm
- 03** Standard casing 100 mm
- 04** Integral casing overall height 150 mm
- 05** Standard casing 150 mm
- 06** Optional manual release
- 07** Underfloor routing

Wall/lintel installation

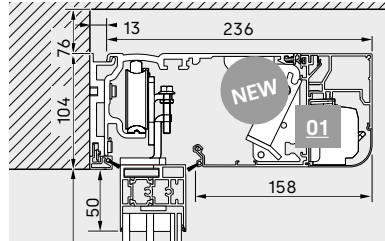

Installation with light metal beam

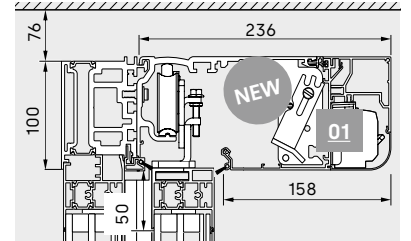

Installation in suspended ceiling

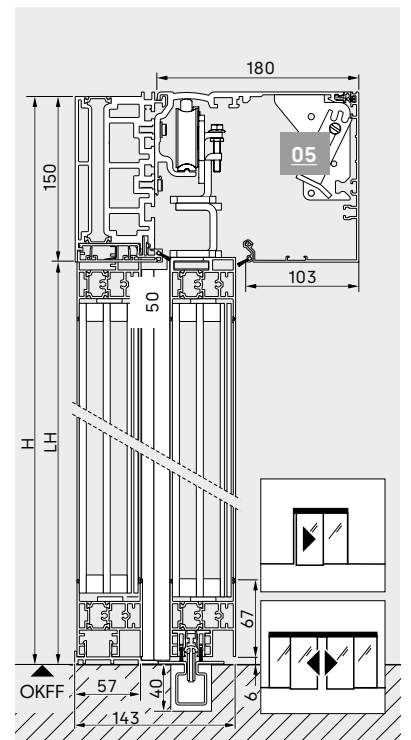
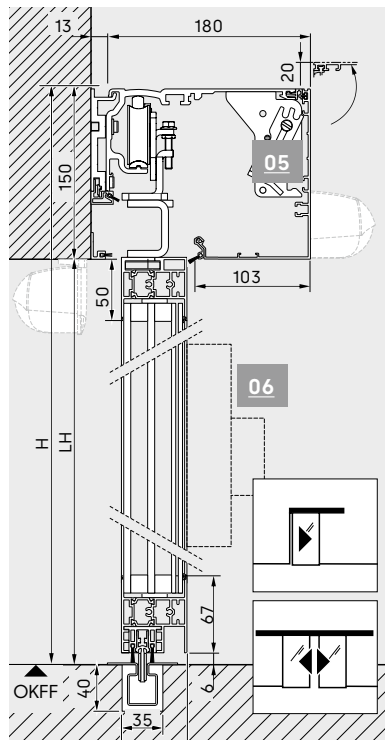
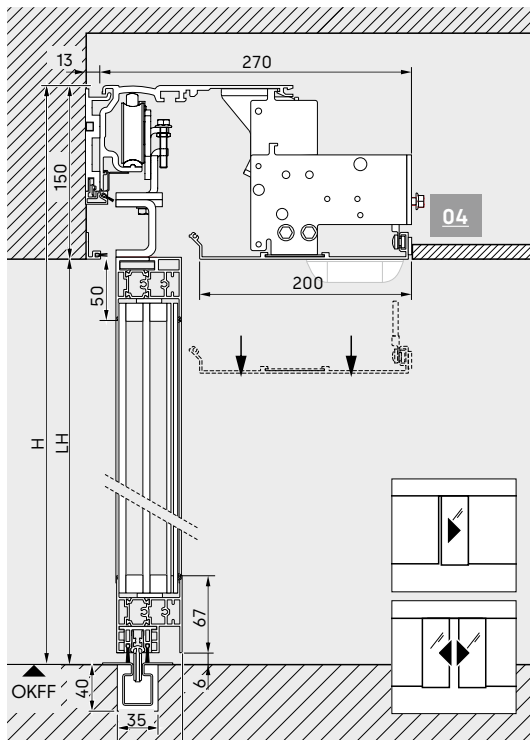
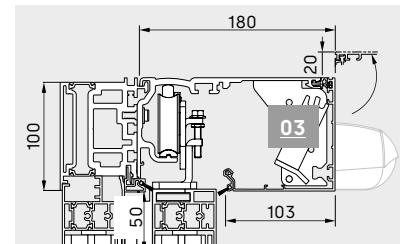
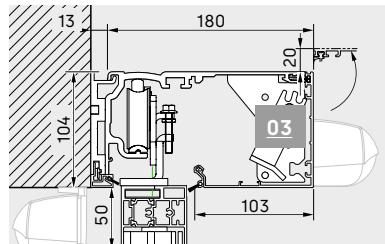
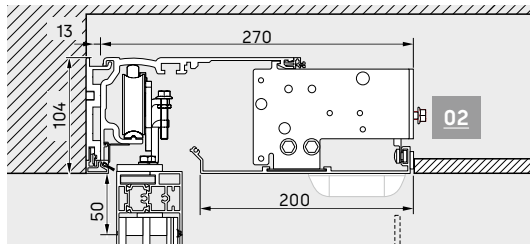

Secondary closing edge variants

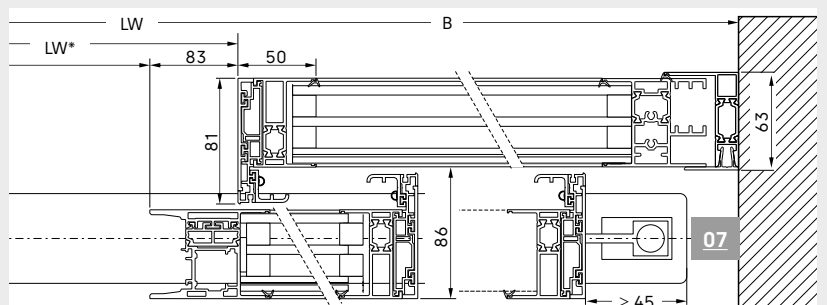
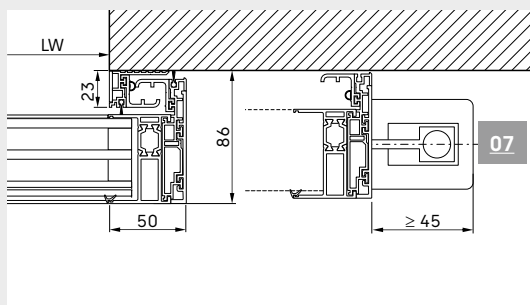

Lintel installation variant

Variants with side panels *with manual release (p. 34) and protective leaf (s. 31)

ST FLEX

Extra slim profile system

Properties

- Slim profile cross-sections
- Safety secondary closing edge made of rubber
- Suitable for ISO glass and toughened glass
- Above-floor and underfloor routing possible
- Also available as telescopic sliding door
- Environmental Product Declaration (EPD) included

Glazings

- Safety glass ESG or VSG in 8 or 10 mm
- Insulating glass ISO 22 with different U-values
- Special glazing



Possible additions

- Protective leaf in front of the moving leaf in combination with ISO glass
- Protective leaf in the façade
- Georgian bar profile
- Underfloor routing
- Manual floor locks

Approximate determination of door leaf weight

$$TG = \frac{LH [m] \times LW [m] \times \text{glass weight [kg/m}^2]}{\text{Number of door leaves}}$$

Common glass weights: ESG 8mm = 20 kg/m², VSG 10mm = 25 kg/m², ISO 22, 2xVSG 6 = 30 kg/m²

		Version	ST FLEX
Drive type		Standard	ES 250 PRO/ES 400 PRO
		Escape route 	ES 250 PRO FST/ES 400 PRO FST
Door parameters*			
System width (B) min. =	1-leaf	Passageway installation (without safety clearance, without post width)	2 x LW + 80 mm
		Wall mounting, without post width	2 x LW + 49 mm
	2-leaf	Passageway installation (without safety clearance)	2 x LW + 98 mm
		Wall mounting	2 x LW + 98 mm
Clearance width LW²	1-leaf	Standard	700 – 3,000 mm
		Escape route 	700 – 3,000 mm
	2-leaf	Standard	800 – 3,000 mm
		Escape route 	800 – 3,000 mm
Max. door leaf weight	1-leaf	ES 250 PRO/ES 250 PRO FST	1 x 125 kg
		ES 400 PRO/ES 400 PRO FST	1 x 250 kg
	2-leaf	ES 250 PRO/ES 250 PRO FST	2 x 125 kg
		ES 400 PRO/ES 400 PRO FST	2 x 200 kg
Clear passage height LH*			2,000 – 3,000 mm



The requirements in escape routes are met by all systems that are equipped with an operator from the ES PROLINE FST series.

* The maximum practicable dimensions are subject to the respective door plans and door requirements and also depend on the profile system selected. For doors with tested anti-intruder protection, increased requirements are placed on the structural tolerances as well as the careful design of the structure.

*2 The minimum clearance width for escape route sliding doors is laid down in the respective regional building codes and may vary in certain circumstances.

Main closing edge variants

- LW:** Clearance width
- LH:** Clearance height
- B:** Total system width
- OH:** Skylight height (option)
- H:** Total system height
- AH:** Drive height 100 or 150 mm dependent on version
- OKFF:** Upper edge of finished floor prefabricated floor

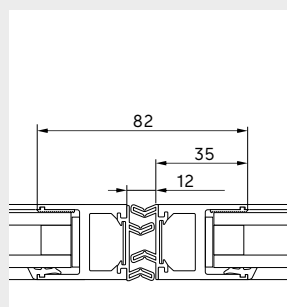

Opening to both sides

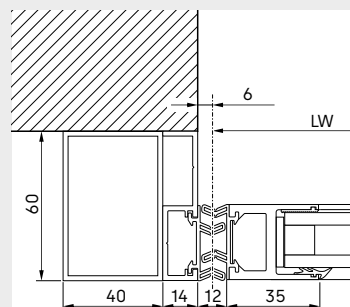

Lintel installation, opening to one side

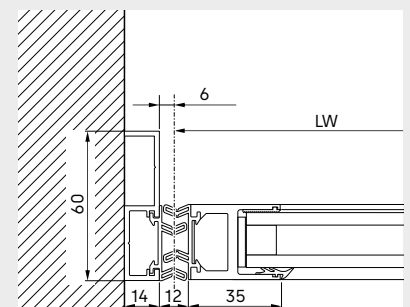

Passageway installation, opening to one side

Note on installation with light metal beam

For units with a drive height of 100 mm, the following sizes are used for the LM support profile are used:

- Total width up to 5 m or max. leaf weight 2 x 85 kg or 1 x 100 kg: 100 x 36 mm
- from 5 m or leaf weight >2 x 85 kg or >1 x 100 kg: 100 x 53 mm

With a total leaf weight of more than 2 x 125 kg, an additional drive suspension is required and/or the 150 mm drive version is necessary.

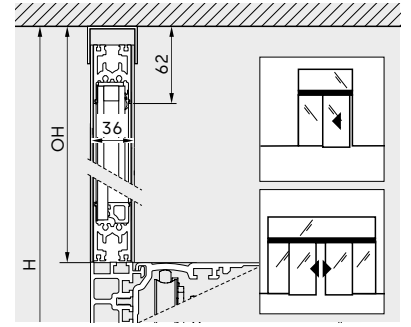

Installation variations and drive casings

- 01** Sensor casing 100 mm
- 02** Integral casing overall height 100 mm
- 03** Standard casing 100 mm
- 04** Integral casing overall height 150 mm
- 05** Standard casing 150 mm

Wall/lintel installation

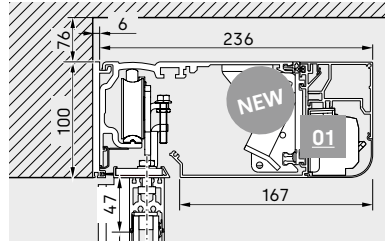

Installation with light metal beam

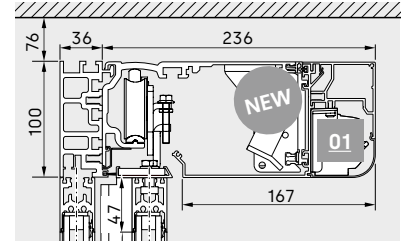

Installation in suspended ceiling

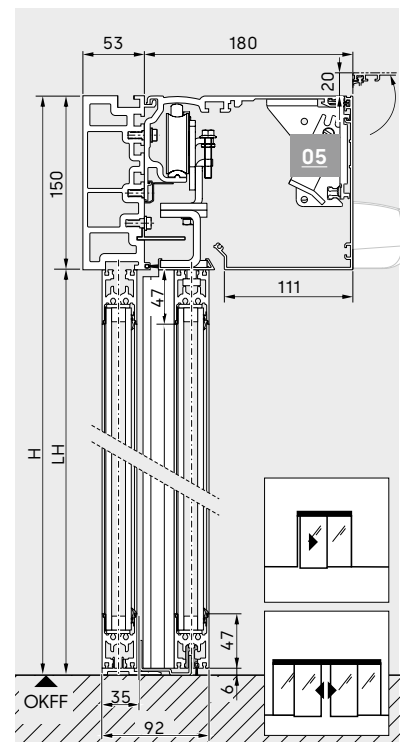
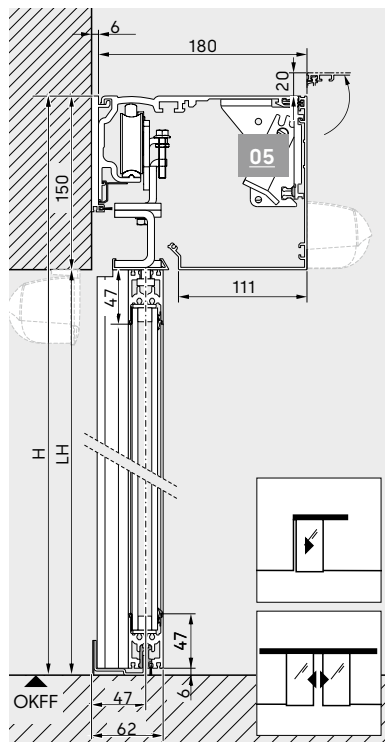
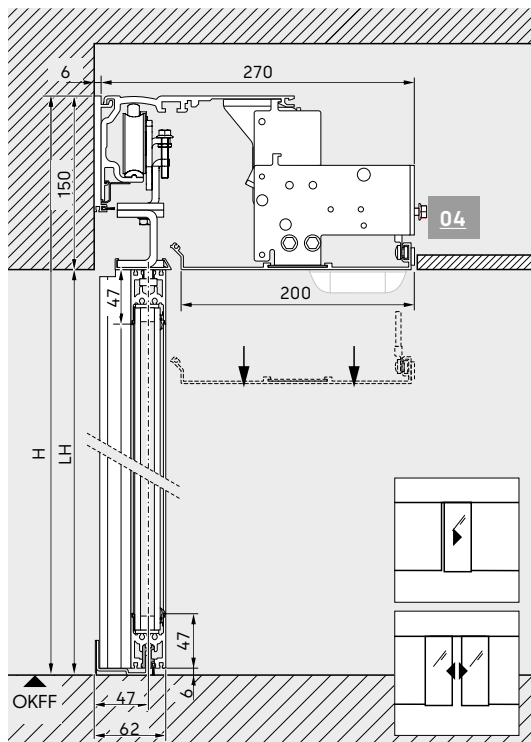
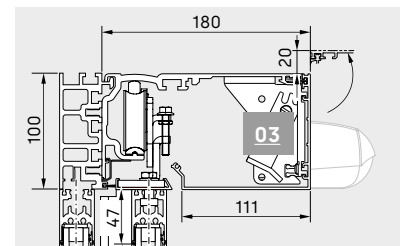
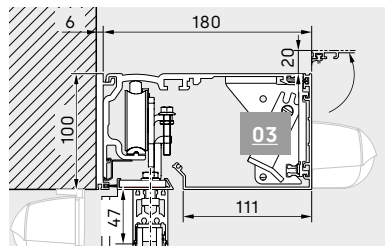
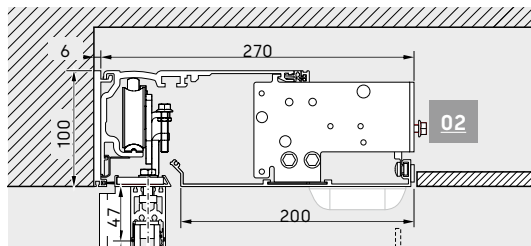

Secondary closing edge variants

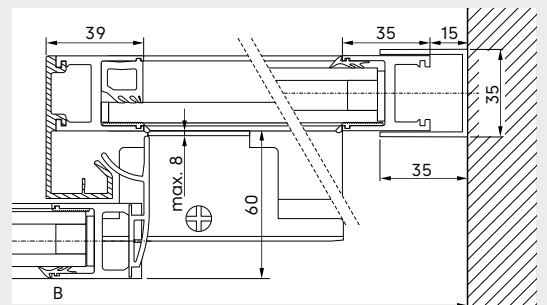
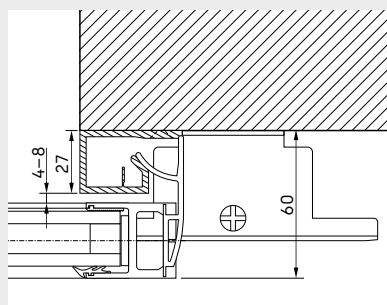
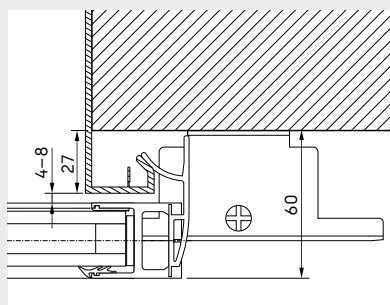

Variant A

Variant B

Variants with side panels

ST FLEX Green

Profile system with improved thermal insulation

Properties

- Complies with the current German Building Energy ACT GEG (formerly EnEV)
- UD values from 1.4 to max. 1.8 W/m²K calculated individually for each door system
- Minimised profile face widths
- Above-floor and underfloor routing possible
- Drive height 100 mm
- Certified thermal conductivity values to EN ISO 10077
- Environmental Product Declaration (EPD) included

Glazings

- Double glazing ISO 28 with warm edge
- Triple glazing ISO 30 with warm edge
- Special glazing



Possible additions

- Protective leaf in front of the moving leaf or in the façade
- Georgian bar profile
- Underfloor routing
- Manual floor locks
- Manual hook-bolt lock

Approximate determination of door leaf weight

$$T_G = \frac{LH [m] \times LW [m] \times \text{glass weight [kg/m}^2]}{\text{Number of door leaves}}$$

Common glass weights: ISO 28 oder ISO 30, 2xVSG6 = 30 kg/m²

		Version	ST FLEX Green
Drive type		Standard	ES 250 PRO/ES 400 PRO
		Escape route 	ES 250 PRO FST/ES 400 PRO FST
Door parameters*			
System width (B) min. =	1-leaf	Passageway installation (without safety clearance, without post width)	2 x LW + 80 mm
		Wall mounting, without post width	2 x LW + 60 mm
	2-leaf	Passageway installation (without safety clearance)	2 x LW + 120 mm
		Wall mounting	2 x LW + 120 mm
Clearance width LW²	1-leaf	Standard	700 – 3,000 mm
		Escape route 	700 – 3,000 mm
	2-leaf	Standard	800 – 3,000 mm
		Escape route 	800 – 3,000 mm
Max. door leaf weight	1-leaf	ES 250 PRO/ES 250 PRO FST	1 x 125 kg
		ES 400 PRO/ES 400 PRO FST	1 x 250 kg
	2-leaf	ES 250 PRO/ES 250 PRO FST	2 x 125 kg
		ES 400 PRO/ES 400 PRO FST	2 x 200 kg
Clear passage height LH*			2,000 – 3,000 mm



The requirements in escape routes are met by all systems that are equipped with an operator from the ES PROLINE FST series.

* The maximum practicable dimensions are subject to the respective door plans and door requirements and also depend on the profile system selected. For doors with tested anti-intruder protection, increased requirements are placed on the structural tolerances as well as the careful design of the structure.

*2 The minimum clearance width for escape route sliding doors is laid down in the respective regional building codes and may vary in certain circumstances.

Main closing edge variants

- LW:** Clearance width
- LH:** Clearance height
- B:** Total system width
- OH:** Skylight height (option)
- H:** Total system height
- AH:** Drive height 100 or 150 mm dependent on version
- OKFF:** Upper edge of finished floor prefabricated floor

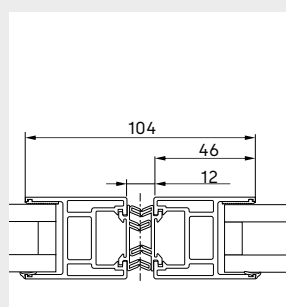

Opening to both sides

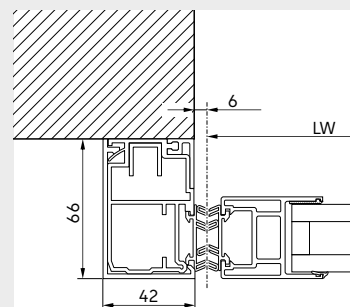

Lintel installation, opening to one side

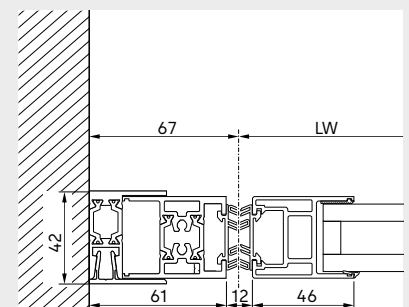

Passageway installation, opening to one side

Note on installation with light metal beam

If the total leaf weight exceeds 2 x 125 kg, an additional drive suspension is required and/or the 150 mm drive version is necessary.

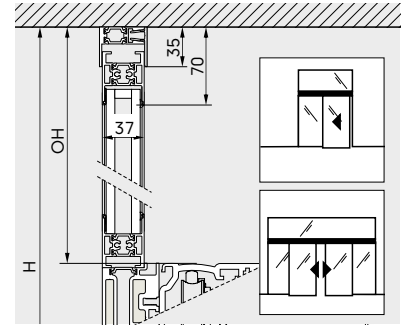

Installation variations and drive casings

- 01** Sensor casing 100 mm
- 02** Integral casing overall height 100 mm
- 03** Standard casing 100 mm
- 04** Integral casing overall height 150 mm
- 05** Standard casing 150 mm

Wall/lintel installation

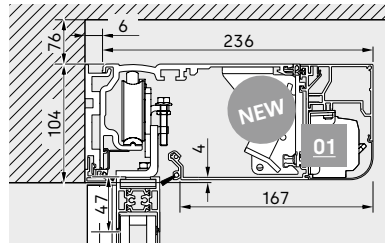

Installation with light metal beam

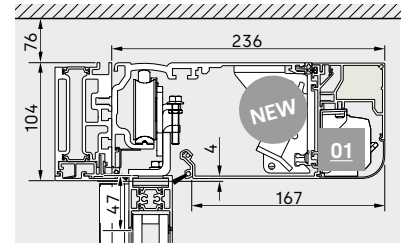

Installation in suspended ceiling

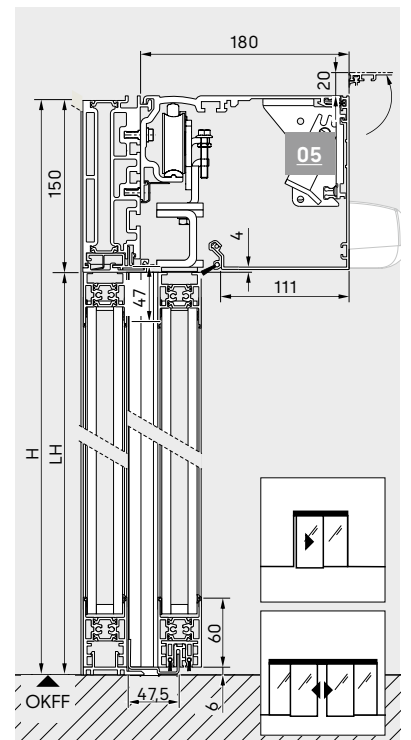
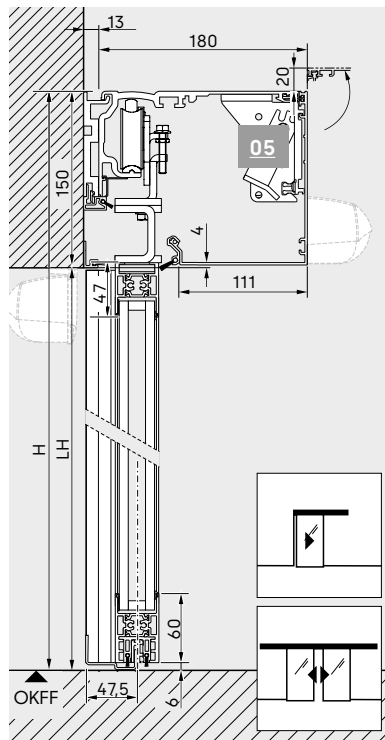
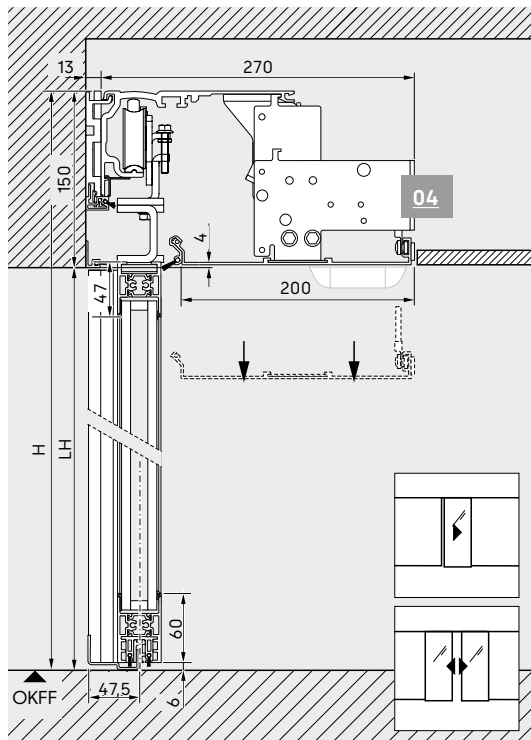
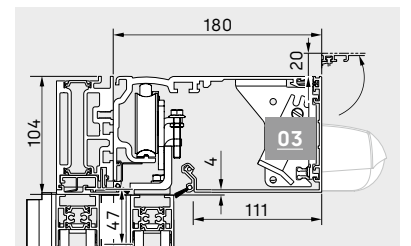
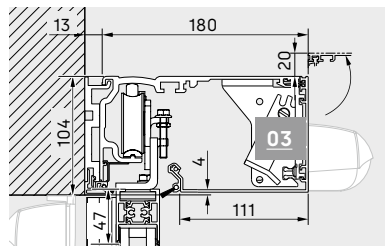
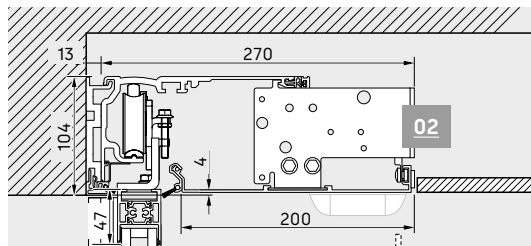

Secondary closing edge variants

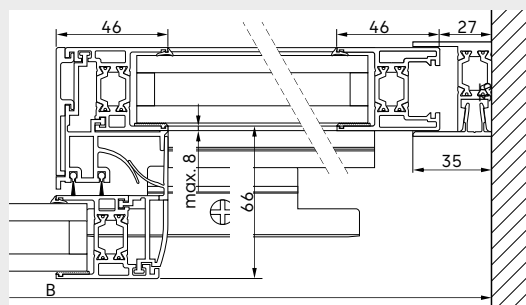
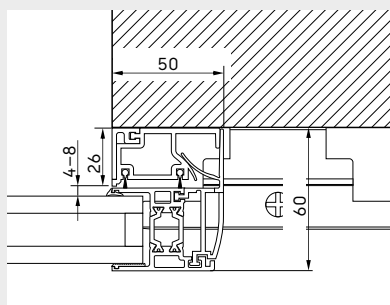

Variants without side panels

Variants with side panels

ST PURE

All-glass system

Properties

- All-glass door leaf without door profiles
- For interior doors
- Door leaf bracket with discreet dimensions
- For doors with and without side panel or fanlight

Glazings

- ESG 10 mm
- Special glazing

Possible additions

- Protection leaf in the façade

Approximate determination of door leaf weight

$$T_G = \frac{LH [m] \times LW [m] \times \text{glass weight [kg/m}^2]}{\text{Number of door leaves}}$$

Common glass weights: ESG 10 mm = 25 kg/m²



		Version	ST PURE
Drive type		Standard	ES 250 PRO/ES 400 PRO
		Escape route	ES 250 PRO FST/ES 400 PRO FST
Door parameters*			
System width (B) min. =	1-leaf	Passageway installation (without safety clearance, without post width)	2 x LW + 80 mm
		Wall mounting, without post width	2 x LW + 70 mm
	2-leaf	Passageway installation (without safety clearance)	2 x LW + 140 mm
		Wall mounting	2 x LW + 140 mm
Clearance width LW ²	1-leaf	Standard	700 – 1600 mm
		Escape route	700 – 1,600 mm
	2-leaf	Standard	800 – 2,000 mm
		Escape route	800 – 2,000 mm
Max. door leaf weight	1-leaf	ES 250 PRO/ES 250 PRO FST	1 x 100 kg
		ES 400 PRO/ES 400 PRO FST	1 x 100 kg
	2-leaf	ES 250 PRO/ES 250 PRO FST	2 x 100 kg
		ES 400 PRO/ES 400 PRO FST	2 x 100 kg
Clear passage height LH*			2,000 – 2,500 mm



The requirements in escape routes are met by all systems that are equipped with an operator from the ES PROLINE FST series.

* The maximum practicable dimensions are subject to the respective door plans and door requirements and also depend on the profile system selected. For doors with tested anti-intruder protection, increased requirements are placed on the structural tolerances as well as the careful design of the structure.

*2 The minimum clearance width for escape route sliding doors is laid down in the respective regional building codes and may vary in certain circumstances.

Main closing edge variants

- LW:** Clearance width
- LH:** Clearance height
- B:** Total system width
- OH:** Skylight height (option)
- H:** Total system height
- AH:** Drive height 100 or 150 mm dependent on version
- OKFF:** Upper edge of finished floor prefabricated floor

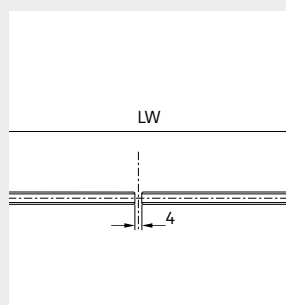

Opening to both sides

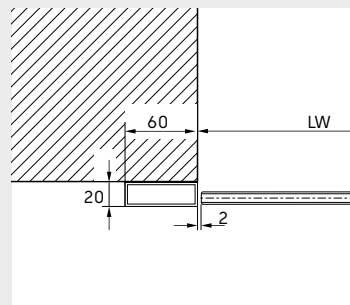

Lintel installation, opening to one side

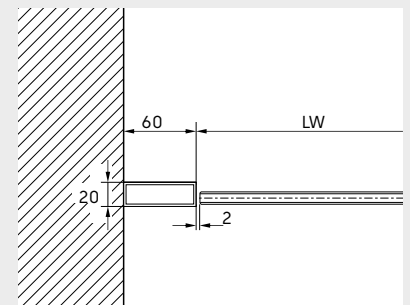

Passageway installation, opening to one side

Installation variations and drive casings

- 01** Sensor casing 100 mm
- 02** Integral casing overall height 100 mm
- 03** Standard casing 100 mm
- 04** Integral casing overall height 150 mm
- 05** Standard casing 150 mm

Note on installation with light metal beam

For units with a drive height of 100 mm, the following sizes are used for the LM support profile are used:

- Total width up to 5 m or max. leaf weight 2 x 85 kg or 1 x 100 kg: 100 x 36 mm
- from 5 m or leaf weight >2 x 85 kg: 100 x 53 mm

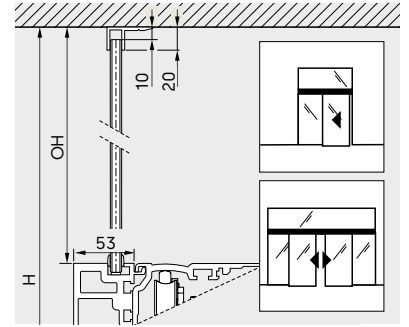

Installation in suspended ceiling

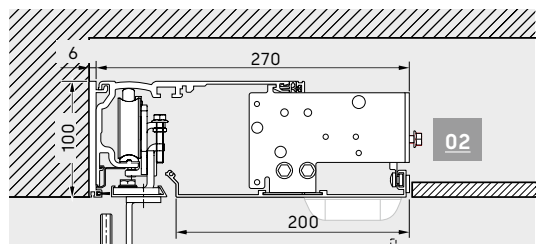

Wall/lintel installation

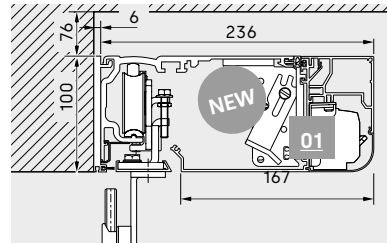

Installation with light metal beam

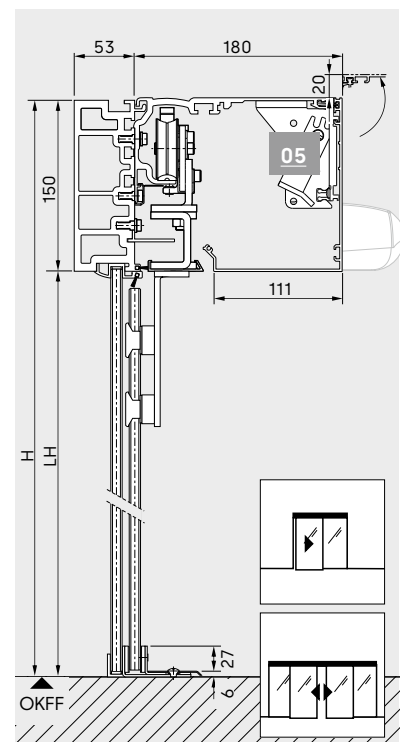
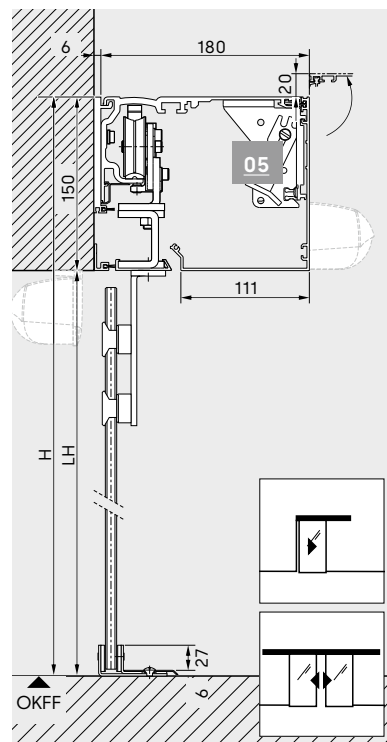
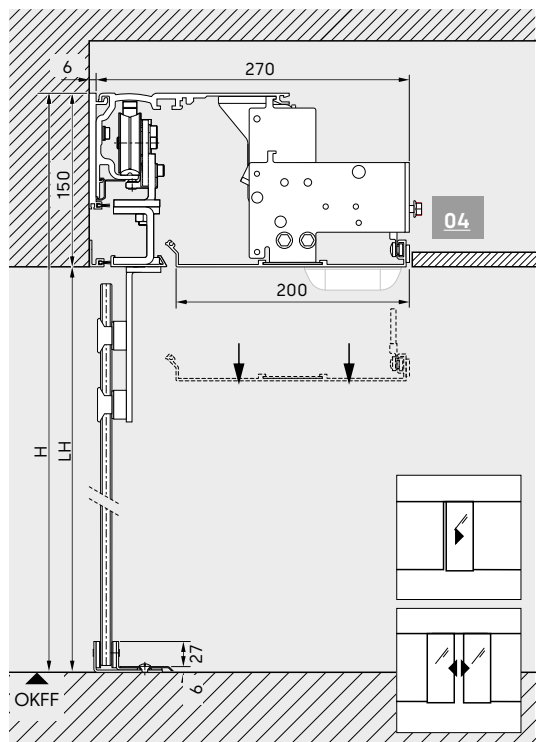
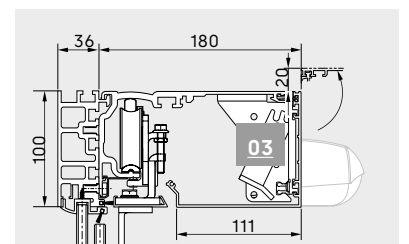
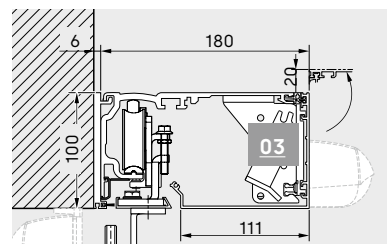
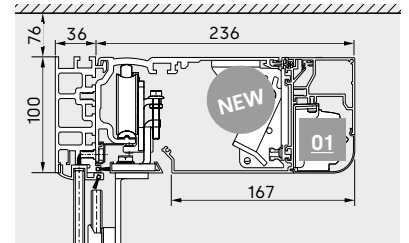

Secondary closing edge variants

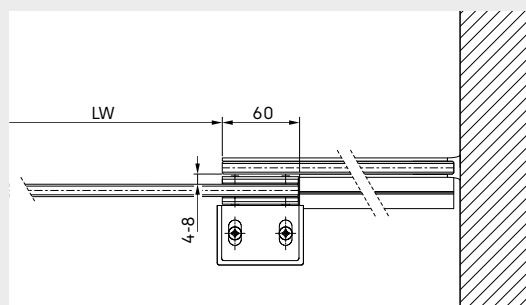
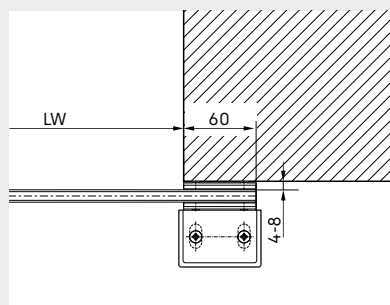

Variants without side panels

Variants with side panels

ST MANET

Stainless steel all-glass system

Properties

- High-quality stainless steel single-point fixings for door-leafs
- Door leaf without profiles for maximum transparency
- For high-quality interior design
- For doors with and without side panel or fanlight

Glazings

- ESG 10 mm
- Special glazing

Possible additions

- Protection leaf in the façade

Approximate determination of door leaf weight

$$T_G = \frac{LH [m] \times LW [m] \times \text{glass weight [kg/m}^2]}{\text{Number of door leaves}}$$

Common glass weights: ESG 10 mm = 25 kg/m²



		Version	ST MANET
Drive type		Standard	ES 250 PRO/ES 400 PRO
		Escape route	ES 250 PRO FST/ES 400 PRO FST
Door parameters*			
System width (B) min. =	1-leaf	Passageway installation (without safety clearance, without post width)	2 x LW + 80 mm
		Wall mounting, without post width	2 x LW + 70 mm
	2-leaf	Passageway installation (without safety clearance)	2 x LW + 140 mm
		Wall mounting	2 x LW + 140 mm
Clearance width LW²	1-leaf	Standard	700 – 1,600 mm
		Escape route	700 – 1,600 mm
	2-leaf	Standard	800 – 2,000 mm
		Escape route	800 – 2,000 mm
Max. door leaf weight	1-leaf	ES 250 PRO/ES 250 PRO FST	1 x 100 kg
		ES 400 PRO/ES 400 PRO FST	1 x 100 kg
	2-leaf	ES 250 PRO/ES 250 PRO FST	2 x 100 kg
		ES 400 PRO/ES 400 PRO FST	2 x 100 kg
Clear passage height LH*			2,000 – 2,500 mm



The requirements in escape routes are met by all systems that are equipped with an operator from the ES PROLINE FST series.

* The maximum practicable dimensions are subject to the respective door plans and door requirements and also depend on the profile system selected. For doors with tested anti-intruder protection, increased requirements are placed on the structural tolerances as well as the careful design of the structure.

*2 The minimum clearance width for escape route sliding doors is laid down in the respective regional building codes and may vary in certain circumstances.

Main closing edge variants

- LW:** Clearance width
- LH:** Clearance height
- B:** Total system width
- OH:** Skylight height (option)
- H:** Total system height
- AH:** Drive height 100 or 150 mm dependent on version
- OKFF:** Upper edge of finished floor prefabricated floor

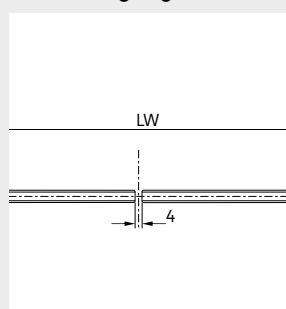

Opening to both sides

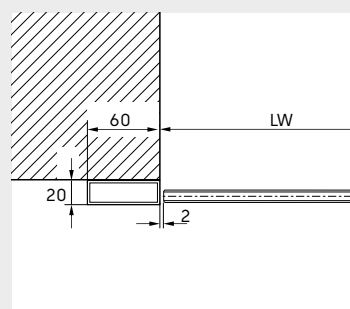

Lintel installation, opening to one side

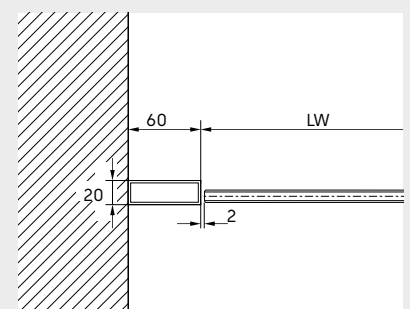

Passageway installation, opening to one side

Installation variations and drive casings

- 01** Sensor casing 100 mm
- 02** Integral casing overall height 100 mm
- 03** Standard casing 100 mm
- 04** Integral casing overall height 150 mm
- 05** Standard casing 150 mm

Note on installation with light metal beam

For units with a drive height of 100 mm, the following sizes are used for the LM support profile are used:

- Total width up to 5 m or max. leaf weight 2 x 85 kg or 1 x 100 kg: 100 x 36 mm
- from 5 m or leaf weight >2 x 85 kg: 100 x 53 mm

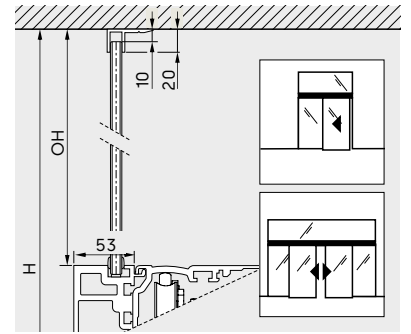

Installation in suspended ceiling

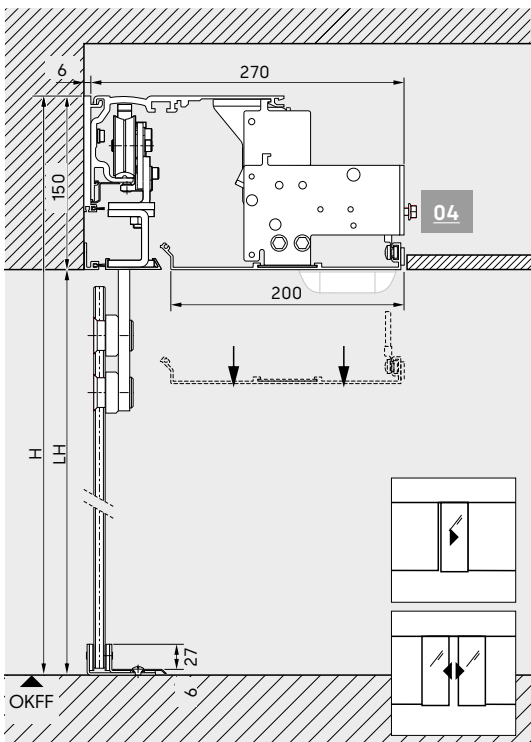
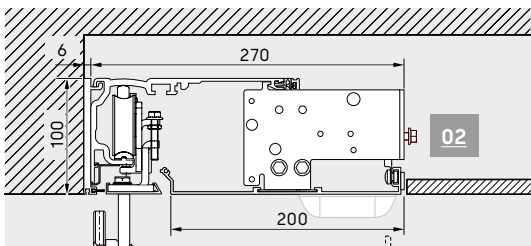

Wall/lintel installation

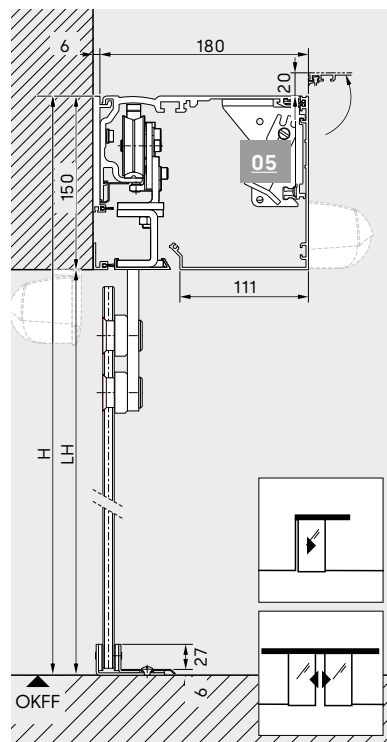
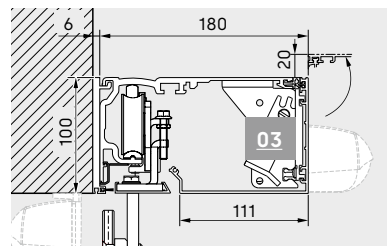
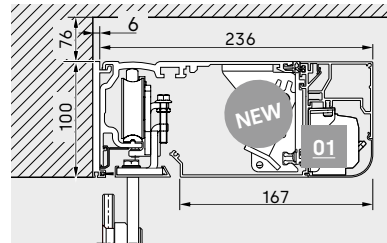

Installation with light metal beam

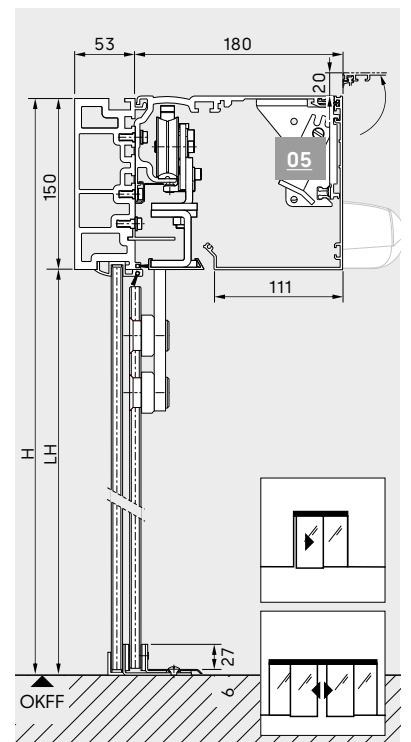
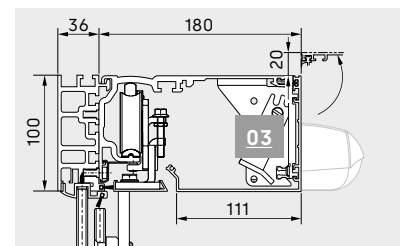
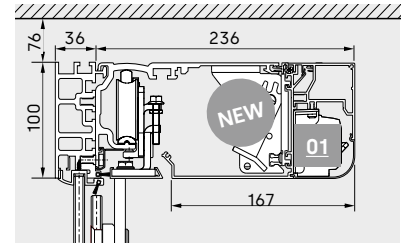

Secondary closing edge variants

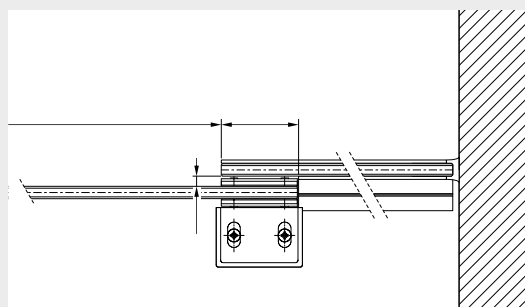
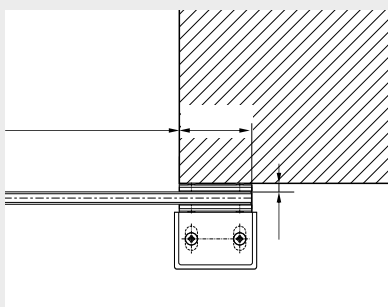

Variants without side panels

Variants with side panels

TST FLEX

Profile system for telescopic doors

Properties

- Telescopic mechanism creates more passage with the same system width
- Slim profile cross-sections
- Secondary closing edge with safety profile
- Version with and without side panel available
- Suitable for ISO glass 22 mm
- Above-floor and underfloor routing possible
- Environmental Product Declaration (EPD) included

Glazings

- Insulating glass ISO 22 with different U-values
- Special glazing



Possible additions

- Protection leaf in the façade
- Georgian bar profile
- Underfloor routing (recommended from LW of 1,400 mm)
- Manual floor locks

Approximate determination of door leaf weight

$$T_G = \frac{LH [m] \times LW [m] \times \text{glass weight [kg/m}^2]}{\text{Number of door leaves}}$$

Common glass weights: ISO 22, 2xVSG6 = 30 kg/m²
 Number of door leaves: 1-leaf = 2 door leaves,
 2-leaf = 4 door leaves.

		Version	TST FLEX
Drive type		Standard	ES 250 PRO T / ES 400 PRO T
		Escape route 	ES 250 PRO T FST / ES 400 PRO T FST
Door parameters*			
System width (B) min. =	1-leaf	Passageway installation (without safety clearance, without post width)	1,5 x LW + 180 mm
		Wall mounting, without post width	1,5 x LW + 122 mm
	2-leaf	Passageway installation (without safety clearance)	1,5 x LW + 180 mm
		Wall mounting	1,5 x LW + 122 mm
Clearance width LW²	1-leaf	Standard	800 – 2,400 mm
		Escape route 	800 – 2,400 mm
	2-leaf	Standard	1,400 – 4,000 mm
		Escape route 	1,400 – 4,000 mm
Max. door leaf weight	1-leaf	ES 250 PRO T / FST	2 x 75 kg
		ES 400 PRO T / FST	2 x 100 kg
	2-leaf	ES 250 PRO T / FST	4 x 75 kg
		ES 400 PRO T / FST	4 x 100 kg
Clear passage height LH*			2,000 – 3,000 mm



The requirements in escape routes are met by all systems that are equipped with an operator from the ES PROLINE FST series.

* The maximum practicable dimensions are subject to the respective door plans and door requirements and also depend on the profile system selected. For doors with tested anti-intruder protection, increased requirements are placed on the structural tolerances as well as the careful design of the structure.

** The minimum clearance width for escape route sliding doors is laid down in the respective regional building codes and may vary in certain circumstances.

Main closing edge variants

- LW:** Clearance width
- LH:** Clearance height
- B:** Total system width
- OH:** Skylight height (option)
- H:** Total system height
- AH:** Drive height 100 or 150 mm dependent on version
- OKFF:** Upper edge of finished floor prefabricated floor

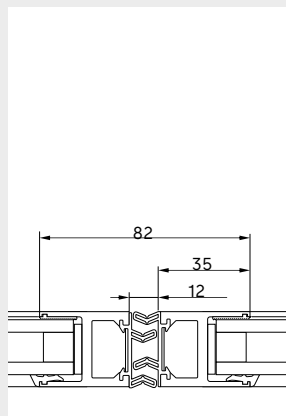

Opening to both sides

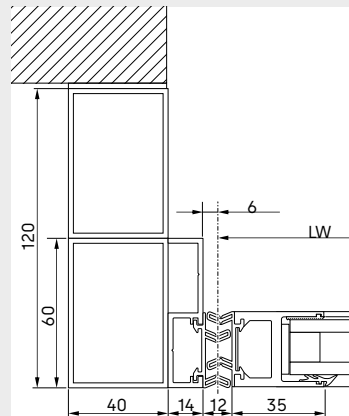

Lintel installation, opening to one side

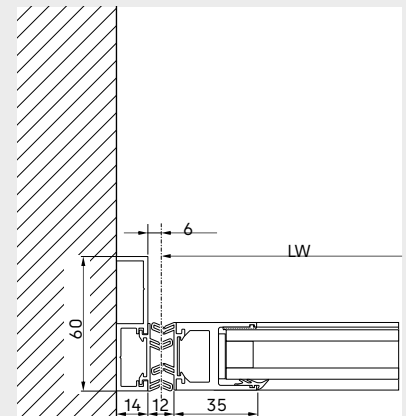

Passageway installation, opening to one side

Note on installation with light metal beam

If the door leaf weight exceeds 2 x 75 kg or 4 x 75 kg, an additional drive suspension and/or the 150 mm drive version is required.

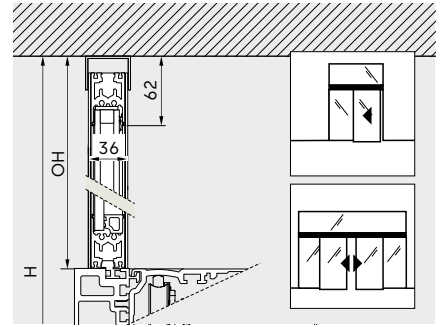

Installation variations and drive casings

- 01** Sensor casing 100 mm
- 02** Integral casing overall height 100 mm
- 03** Standard casing 100 mm
- 04** Integral casing overall height 150 mm
- 05** Standard casing 150 mm

Wall/lintel installation

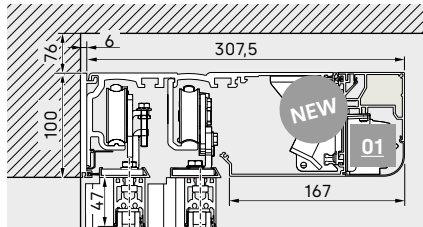

Installation with light metal beam

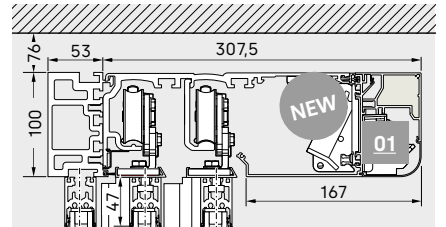

Installation in suspended ceiling

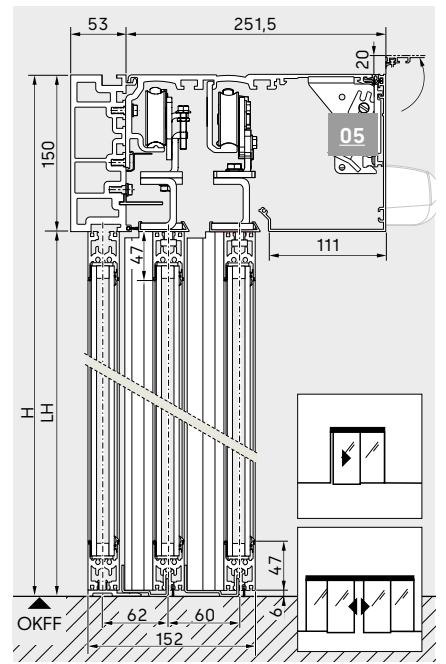
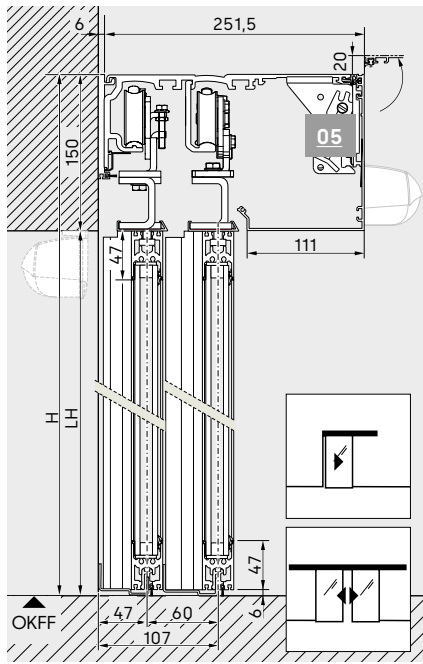
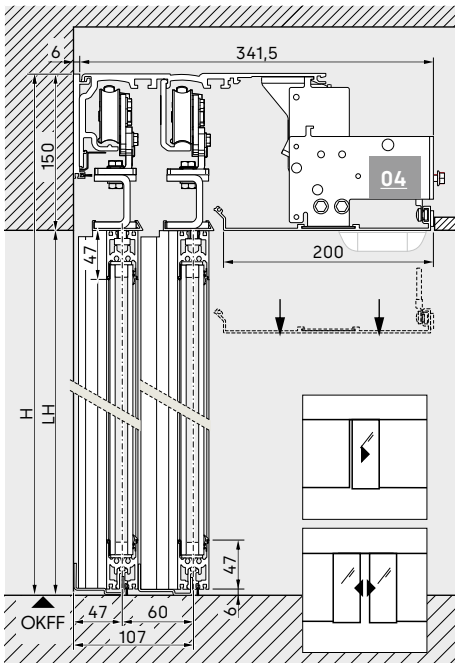
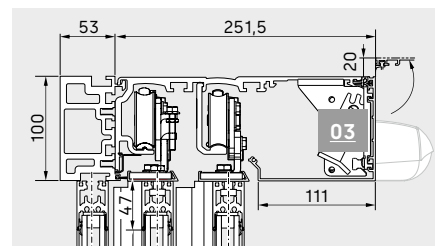
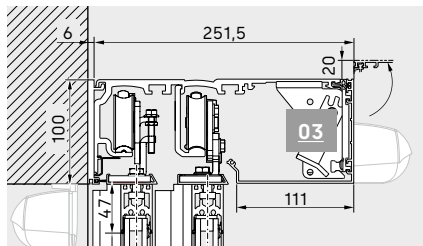
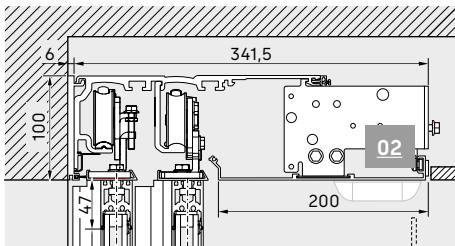

Secondary closing edge variants

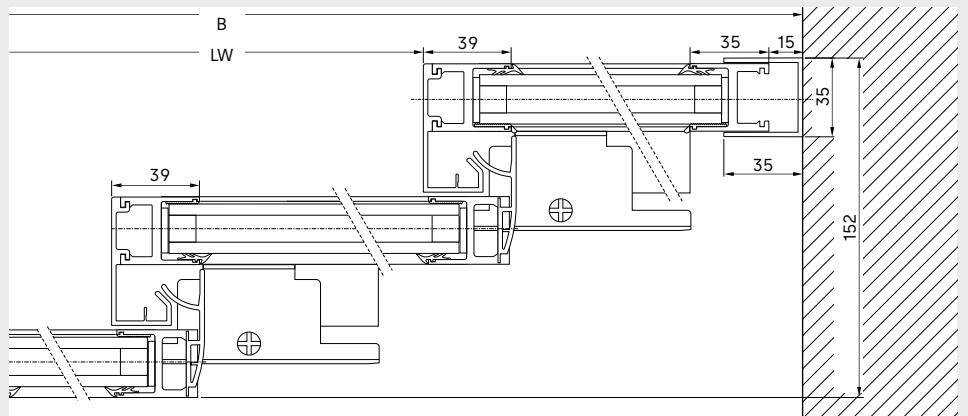
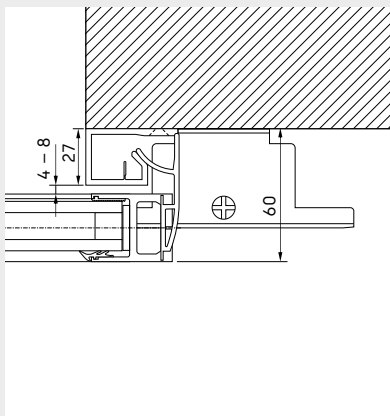

Variants without side panels

Variants with side panels

TST FLEX Green

Telescopic door with improved thermal insulation

Properties

- Telescopic mechanism creates more passage with the same system width
- Slim profile cross-sections
- Secondary closing edge with safety profile
- Version with and without side panel available
- Suitable for ISO glass 22 mm
- Above-floor and underfloor routing possible

Glazings

- Double glazing ISO 28 with warm edge
- Triple glazing ISO 30 with warm edge
- Special glazing



Possible additions

- Protection leaf in the façade
- Georgian bar profile
- Underfloor routing (recommended from LW of 1,400 mm)
- Manual floor locks
- Manual hook-bolt lock

Approximate determination of door leaf weight

$$T_G = \frac{LH [m] \times LW [m] \times \text{glass weight [kg/m}^2]}{\text{Number of door leaves}}$$

Common glass weights: ISO 28 oder ISO 30, 2xVSG6 = 30 kg/m²
 Number of door leaves: 1-leaf = 2 door leaves,
 2-leaf = 4 door leaves.

		Version	TST FLEX Green
Drive type		Standard	ES 250 PRO T / ES 400 PRO T
		Escape route 	ES 250 PRO T FST / ES 400 PRO T FST
Door parameters*			
System width (B) min. =	1-leaf	Passageway installation (without safety clearance, without post width)	1,5 x LW + 180 mm
		Wall mounting, without post width	1,5 x LW + 122 mm
	2-leaf	Passageway installation (without safety clearance)	1,5 x LW + 180 mm
		Wall mounting	1,5 x LW + 122 mm
Clearance width LW²	1-leaf	Standard	800 – 2,400 mm
		Escape route 	800 – 2,400 mm
	2-leaf	Standard	1,400 – 4,000 mm
		Escape route 	1,400 – 4,000 mm
Max. door leaf weight	1-leaf	ES 250 PRO T / FST	2 x 75 kg
		ES 400 PRO T / FST	2 x 100 kg
	2-leaf	ES 250 PRO T / FST	4 x 75 kg
		ES 400 PRO T / FST	4 x 100 kg
Clear passage height LH*			2,000 – 3,000 mm



The requirements in escape routes are met by all systems that are equipped with an operator from the ES PROLINE FST series.

* The maximum practicable dimensions are subject to the respective door plans and door requirements and also depend on the profile system selected. For doors with tested anti-intruder protection, increased requirements are placed on the structural tolerances as well as the careful design of the structure.
²The minimum clearance width for escape route sliding doors is laid down in the respective regional building codes and may vary in certain circumstances.

Main closing edge variants

- LW:** Clearance width
- LH:** Clearance height
- B:** Total system width
- OH:** Skylight height (option)
- H:** Total system height
- AH:** Drive height 100 or 150 mm dependent on version
- OKFF:** Upper edge of finished floor prefabricated floor

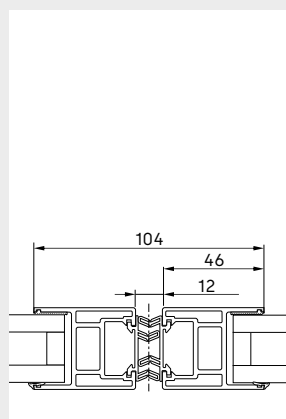

Opening to both sides

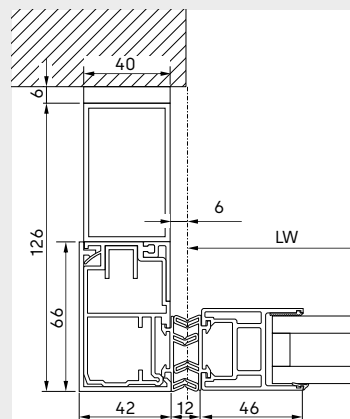

Lintel installation, opening to one side

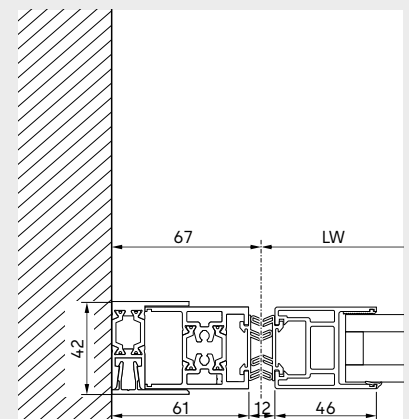

Passageway installation, opening to one side

Note on installation with light metal beam

If the door leaf weight exceeds 2 x 75 kg or 4 x 75 kg, an additional drive suspension and/or the 150 mm drive version is required.

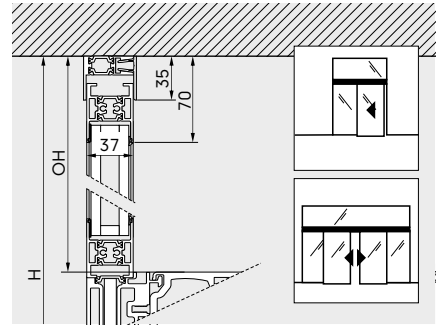

Installation variations and drive casings

- 01** Sensor casing 100 mm
- 02** Integral casing overall height 100 mm
- 03** Standard casing 100 mm
- 04** Integral casing overall height 150 mm
- 05** Standard casing 150 mm

Wall/lintel installation

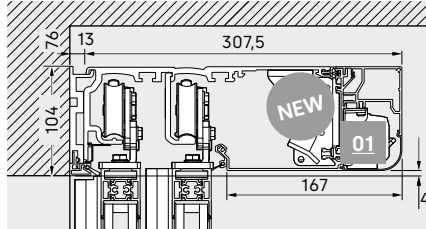

Installation with light metal beam

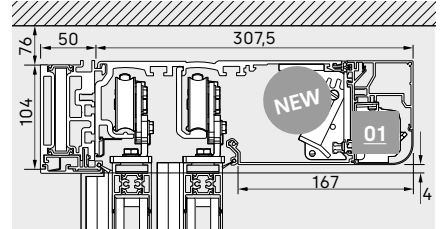

Installation in suspended ceiling

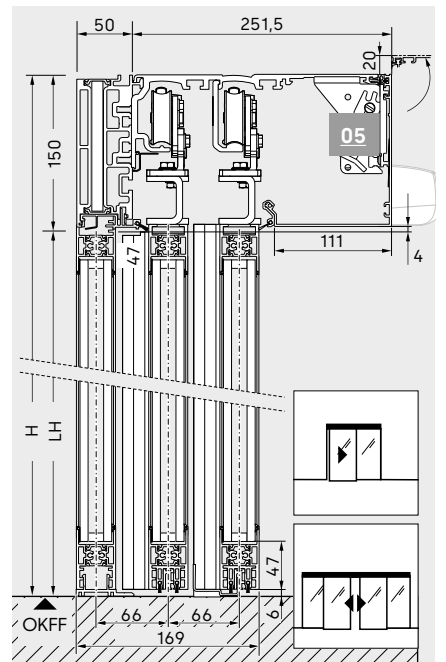
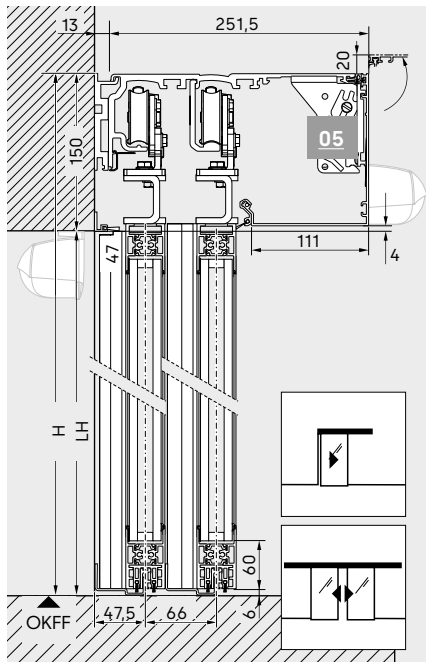
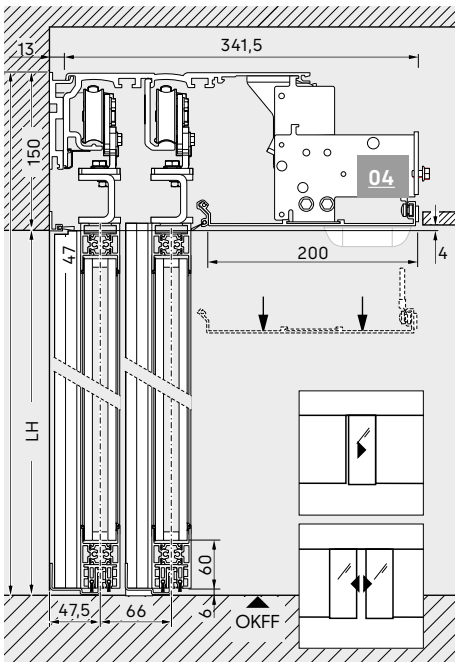
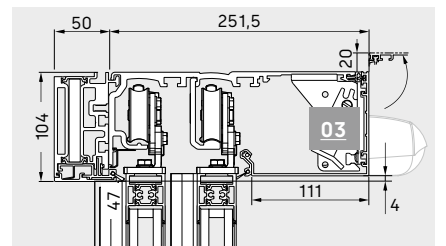
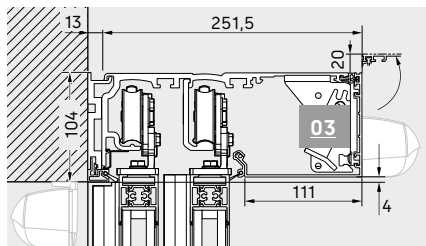
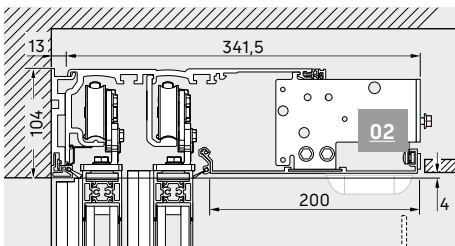

Secondary closing edge variants

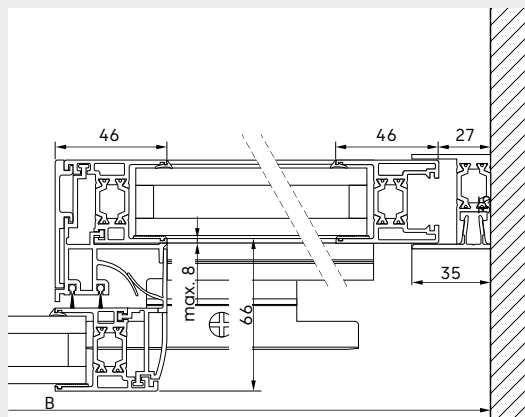
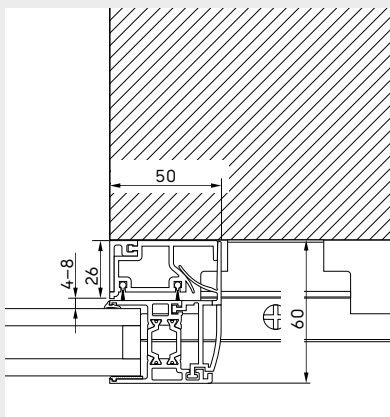

Variants without side panels

Variants with side panels

Casing variants



Standard casing

The standard casing for ES PROLINE operators is available in two different versions (height 100 mm, 150 mm). A cover bracket is supplied as standard and allows the casing to be opened in three different positions.

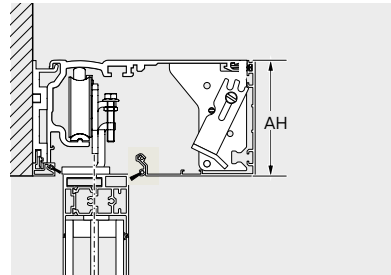

Sensor casing

Sensor casing is the right solution when it comes to premium design requirements. It creates a sleek look for doors with 100 mm drive heights. Activation and safety sensors are integrated into the drive system. There is no need for disruptive additional units and visible components. The sensor casing is approved for doors with a clear passage height of max. 3,000 mm.

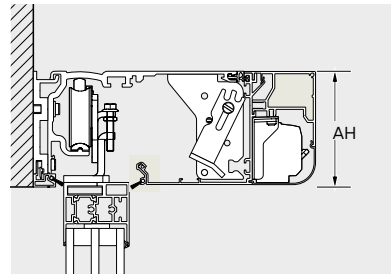

Integrated casing

Integrated casing allows the ES PROLINE operator to be elegantly concealed in suspended ceilings. The operator cover can be detached from below to allow easy access to all the components when carrying out maintenance tasks. Special accessories sets make it possible to integrate the safety sensors in the cover so that the entire height of the passage area can be used.

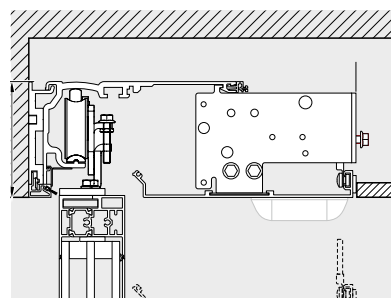

Additional track rail suspension

Optionally available, for instance, for particularly heavy skylight weights.



Additions sliding door system

Protective leaf to safeguard the travel path

A protective leaf safeguards the sliding door's travel path. The protective leaf is located in front of the door leaf and covers the full range of movement. Depending on the local conditions and risk assessment, an additional lateral closure at the outer edge is required to prevent lateral reach-in. The protective leaf can be opened as required, e.g. to clean the glass.

Optional for all ST sliding door systems.
This design is not suitable for telescopic sliding doors TST.

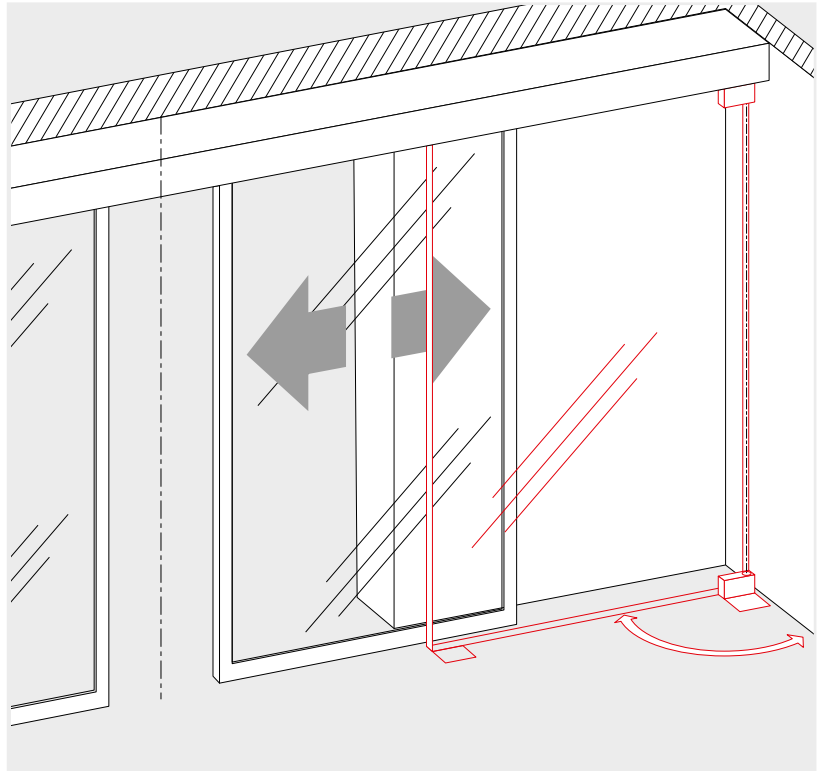

Protective leaf in mullion-transom façades

In mullion-transom façades a protective leaf can safeguard the "clear" space of the façade construction. The protective leaf can be opened as required, e.g. to clean the glass.

Optional for all sliding door systems ST and TST telescopic sliding doors.

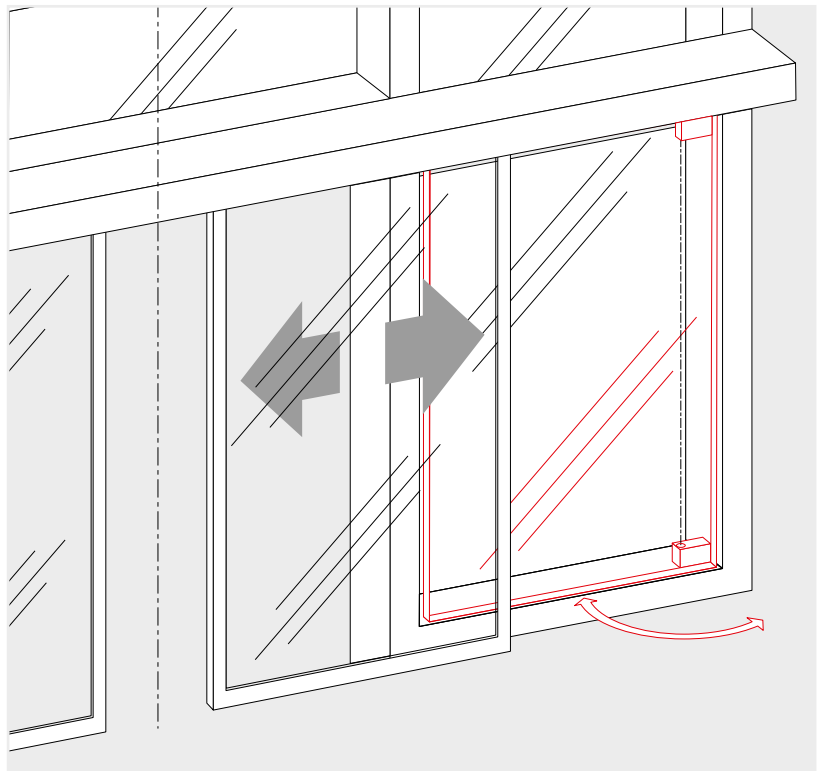

Georgian bar profiles

The door leaves, side panels and skylights can be partitioned with Georgian bars. The Georgian bars serve as a decorative element or even a "shock protection".

The exposed width of the Georgian bars X is depending on the selected profile system. The height of the bar above the floor can be selected.

Profile system	X
ST PRO Green*	90 mm
ST PRO Green RC2/RC3*	90 mm
ST FLEX	80 mm
ST FLEX Green	80 mm
TST FLEX	80 mm
TST FLEX Green	80 mm

Optional only for the specified profile systems.

* Availability on request

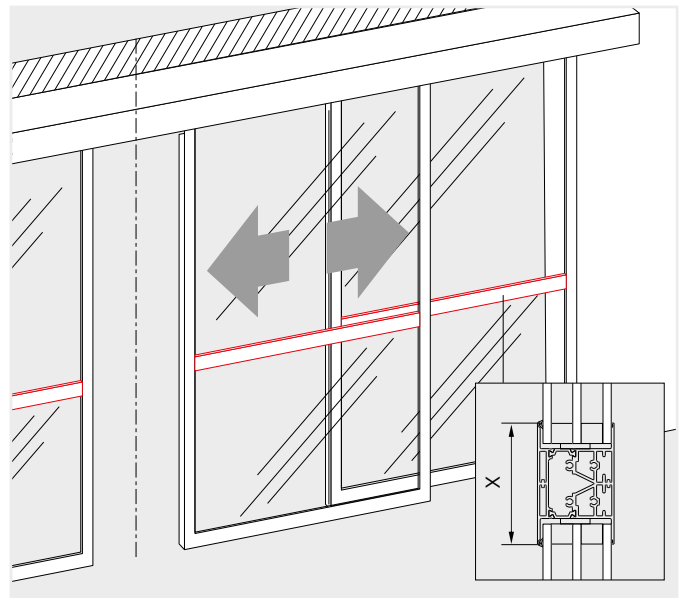

Underfloor guide

Especially for larger opening widths or doors exposed to wind, an underfloor guide provides significant stabilisation of the door leaf guide. The guide rail is made of stainless steel and is prepared at the factory for the connection of a drainage pipe. The continuous guide bar on the door leaves additionally reduces the flow of draughts.

Optional for all profile systems

(standard for ST PRO Green RC2 / RC3)

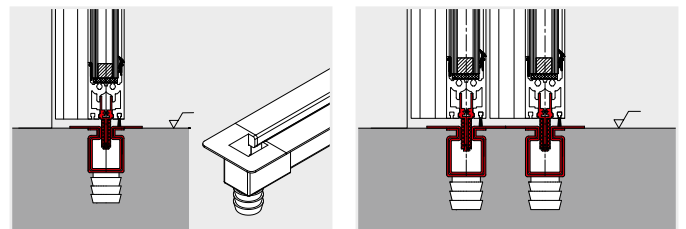
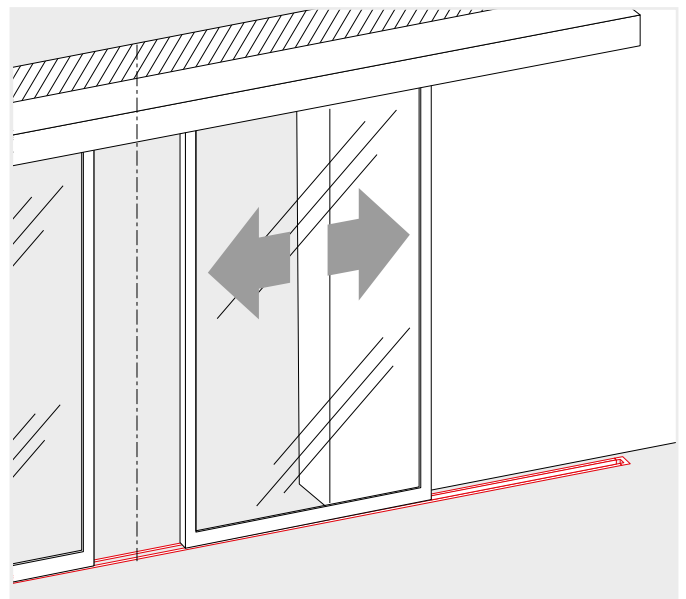

Locking devices

Attached floor lock

Floor locks are used for additional manual security of sliding doors. They can be operated from the inside (with profile half cylinder) or from the inside and outside (with profile full cylinder). In the FLEX and FLEX Green profile systems, the mechanism is located in an attached lock case. With the PRO Green profile system, an integrated version without a lock case is also available for doors without an underfloor guide.

Optional for all profile systems.

The following applies to all types of mechanical locks for doors in escape and rescue routes: Locking is only permitted when there are no persons in the building.

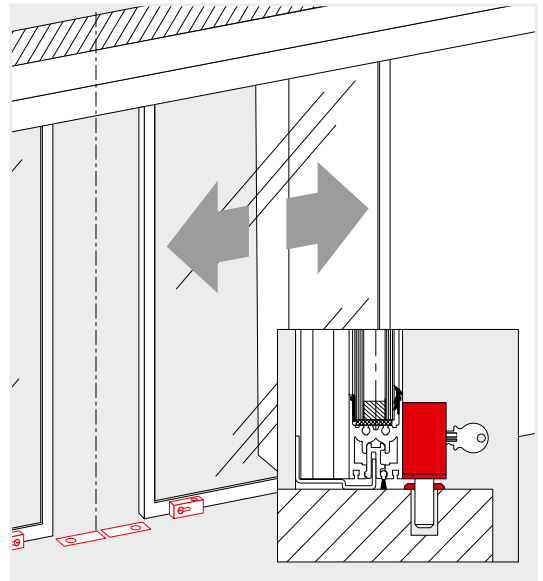

dormakaba offers a range of locking device variants for the ES PROLINE to prevent unauthorised access to buildings by opening the sliding door.

Electro-mechanical belt locking device

The self-adjusting locking device is attached directly to the drive unit of the operator. The standard lock status signal contacts increase the operational safety of the door. The locking device function is configured ex works to be bistable; this means that the locking device status is maintained in the event of a power failure. Versions with other functions (monostable with Failsafe: opens the locking device in the event of a power failure and Failsecure: closes the locking device in the event of a power failure) are also available.

Optional for all sliding door systems with ES PROLINE operator.

The following applies to all types of mechanical locks for doors in escape and rescue routes: Locking is only permitted when there are no persons in the building.

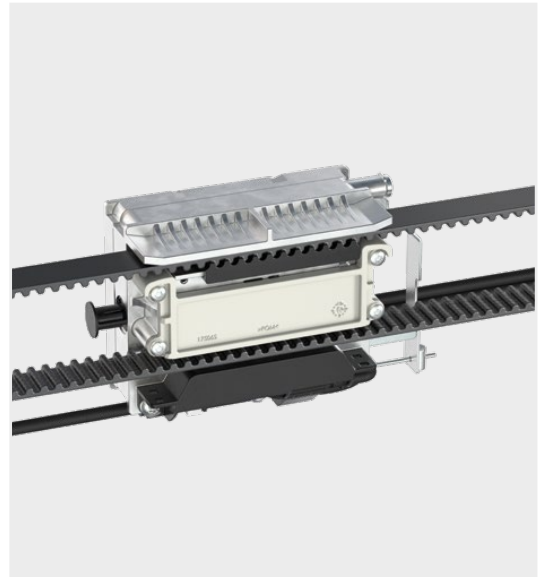

Magnetic locking device (FIA) for escape route and emergency exit doors

When using the magnetic locking device and the ES PROLINE control variant, you can lock an escape route sliding door in all automatic program switch positions, even when persons are present in the building.

The locking device system has been type-approved by the German Technical Inspectorate and does not require approval in each individual case.

This variant is suitable for all properties that are used 24 hours a day, such as self-service areas in banks, hotels, hospitals, schools, etc. Any person can leave the building safely in case of an emergency and the door provides protection against uninvited guests.

Optional for all sliding door systems with ES PROLINE FST operator.



Electromotive hook locking device

This particularly robust multipoint locking device provides a very high level of break-in protection for standard sliding doors and doors of resistance classes RC2/RC3 (doors with increased anti-intruder protection are equipped with these locking devices as standard). Five solid swing bolts are extended by a motor to lock the door. Mechanical unlocking devices for opening doors manually are optionally available. The following applies to all types of mechanical locks for doors used in escape routes and emergency exits: locking is only permitted if there are no persons in the building.

Standard ST PRO Green RC2/RC3 design. Optional for ST PRO Green, ST FLEX Green, ST FLEX.

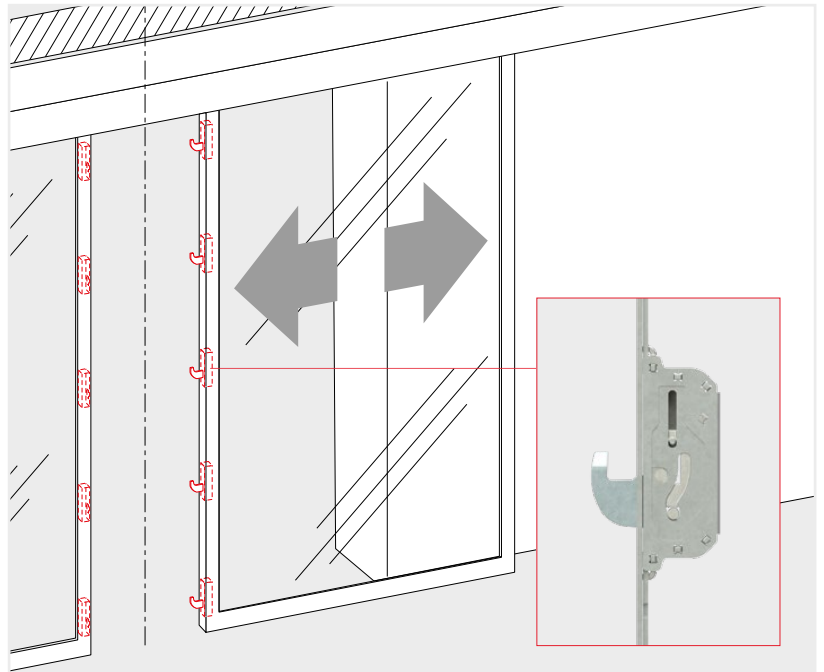

Manual release on the door leaf

With electromotive hook locking, a door can be manually locked and unlocked on the sliding door leaf. For 1-leaf doors, the release is always located on the door leaf. For 2-leaf doors, the release is located on the right-hand door leaf.

Optional for electromotive hook locking.

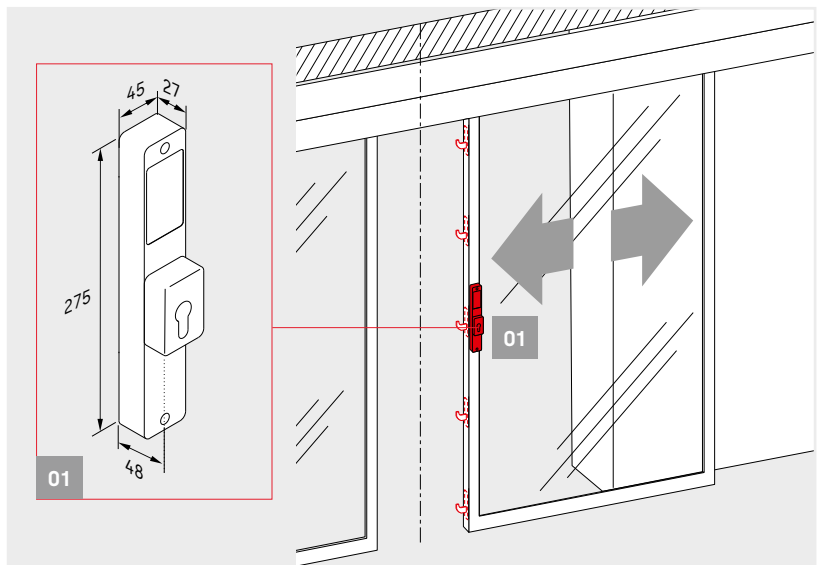

Information on manual release for optional protective leaf

If the sliding door system is equipped with a manual release and a protective leaf, the clearance width LW is reduced by:

- ST PRO Green 1-leaf systems: 83 mm
- ST PRO Green 2-leaf systems: 166 mm

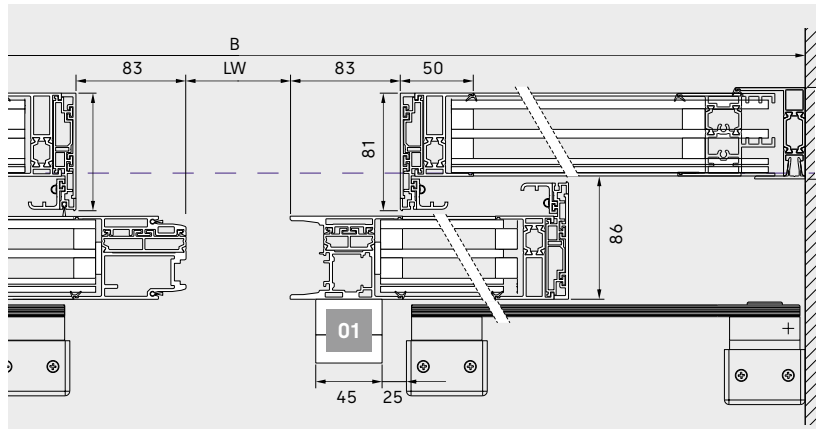

Operators ES PROLINE Variants

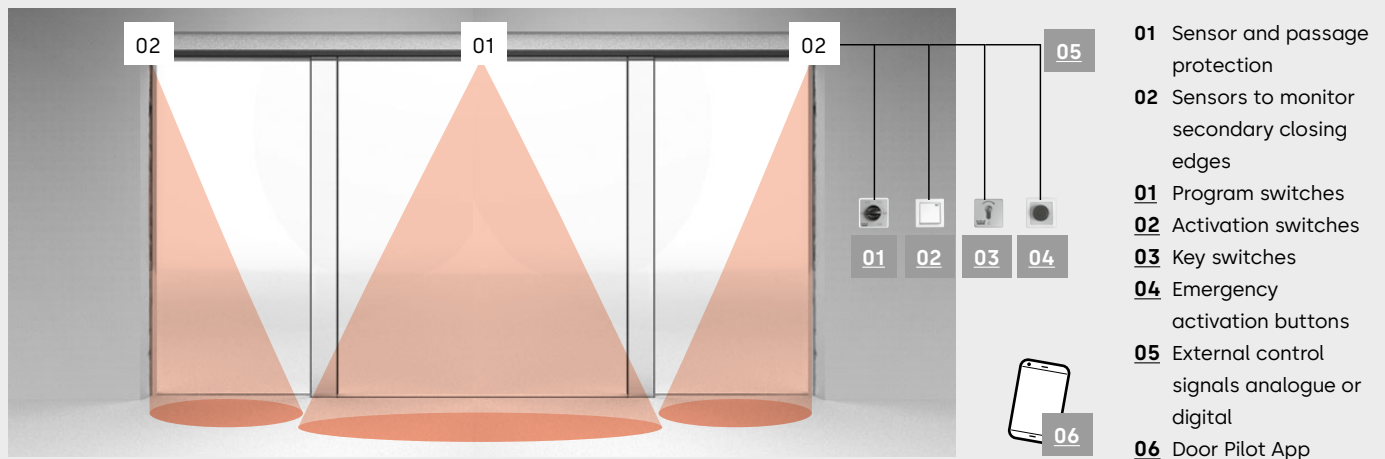

The ES PROLINE drive systems offer an optimal solution for every requirement of a sliding door system. The operators are durable and operate very quietly, quickly and powerfully thanks to the brushless dormakaba Direct Drive motor technology. With over 1.5 million load cycles, the operators are designed to far exceed the requirements in the current standards. This corresponds to a 50 % longer service life of the door system.

The range of functions is determined by the control of the selected drive system. The controller monitors the pulse generators and the sensor systems to ensure safe operation. With the programme switch, additional modules and the optionally connected control elements, the automatic door system can be configured for individual requirements.

PRO EASY operator variants

The entry-level solutions with Direct Drive Unit (DDU) and simple control module with basic range of functions.

ST sliding doors / all-glass sliding doors:

ES 250 PRO EASY

TST telescopic sliding doors:

ES 250 T PRO EASY

Operator variants PRO

For door systems in public areas with extended functional requirements in two weight classes. The ES 400 versions are optimised for large or heavy door leaf weights (up to 400 kg).

ST sliding doors and all-glass sliding doors:

ES 250 PRO

ES 400 PRO

TST telescopic sliding door:

ES 250 PRO T

ES 400 PRO T

Operator variants PRO FST

For door systems in escape and rescue routes with extended functional requirements in two weight classes. The ES 400 versions are optimised for large or heavy door leaf weights (up to 400 kg).

ST sliding doors and all-glass sliding doors:

ES 250 PRO FST

ES 400 PRO FST

TST telescopic sliding doors:

ES 250 PRO T FST

ES 400 PRO T FST

Extension modules and additional equipment

With extension modules and additional equipment, each drive can be supplemented with additional functions as required.

Features and auxiliary equipment

Features

	Operator variant	PRO	PRO FST	PRO EASY
Modular design		●	●	●
Function programs	<ul style="list-style-type: none"> - Off - Automatic - Permanent open - Partial open - Exit 	● ● ● ● ●	● ● ● ● ●	● ● ● ● ●
Automatic reversing		●	●	●
Connection for securing the passageway (on both sides)		●	●	●
Tested in accordance with EN 16005/DIN 18650		●	●	●
Securing main and secondary closing edge(s) according to EN 16005/DIN 18650		●	●	●
Basic parameters set using integrated display and buttons		●	●	●
Parameterisation via Operator Service Interface (OSI)		●	●	●
Door Pilot interface (Bluetooth)		○	○	○
Automatic opening/closing in the event of a power failure (if a battery set is used)		●/●	●/- (Battery set supplied as standard)	●/●
Emergency battery operation (if a battery set is used)		●	-	●
24 V DC output for accessories		●	●	●
Readable fault memory with fault codes		●	●	●
CAN interface for connecting a program switch		●	●	●
CAN interface for connecting additional CAN-bus components		●	●	-
Multiports for connecting accessory components		4	4	2

Auxiliary equipment

Electro-mechanical belt locking device	○	○	○
Manual lock release for electro-mechanical locking device	○	○	○
Magnetic locking device, jam-free	○	○	-
Electromotive hook locking device (up to RC3)	○	○	-
Manual lock release for electromotive locking device	○	○	-
Battery set	○	●	○
Emergency power supply UPS (external)	○	○	○
Module for connection to LON/LAN building control systems	○	○	-
Potential-free relay contact	○	○	○

● as standard ○ optional

Master controller functions and expansion modules

Master controller

	PRO	PRO FST	PRO EASY
Pharmacy function/pharmacy door opening The door can be locked in a partially open position apart from when the program switch is in the "Off" position. This allows a pharmacy to dispense goods securely outside business hours, for example.	●	●	–
Door status signal contacts This function issues door statuses. E.g. Door open/closed/locked, System OK, Current door position.	●	●	●
Panic closing This function closes the door immediately and switches off passage security and force limitation. This function is only permissible in certain countries (observe regional regulations).	●	–	–
Door bell contact For connecting an on-site door bell or an audible indicator.	●	●	–
Airlock function The doors can be switched to function as a personal interlock (not for escape route systems).	●	–	–
Synchronous operation For instance, two doors opening on one side can be switched to act as one large, double-leaf door. This allows particularly wide opening distances or high door leaf weights to be achieved.	●	●	–
Safety deactivation The door can be opened or closed by pressing a button.	●	●	–
Night/bank function Allows the connection of access controls, key switches etc. with the program switch in the "Off" position. The door unlocks – opens – closes – locks.	●	●	●
Emergency open	–	●	–
Emergency stop	●	–	–
Configurable partial opening distance	●	●	●
Slide and Go An opening signal can be triggered by gently pushing the door leaf.	●	●	–
Unlock/lock in case of malfunction In case of system malfunction, a door can be deliberately triggered to close and lock or unlock and open.	●	●	–
Fire service function Used to deliberately open and close a door via a separate signal input.	●	●	–

● Function can be implemented via the four programmable inputs and outputs. – Function is not implementable

Expansion modules

	PRO	PRO FST	PRO EASY
4 I/O Expansion module The 4 I/O module is capable of four inputs and four outputs. The master controller functions can be implemented if the master controller connections have already been assigned. Only one module can be used at a time.	○	○	–
Safety and activation (SiAK) expansion module The safety and activation (SiAK) expansion module is used to connect conventional accessories, such as sensors and radar detectors. Safety sensors can be connected either for the main closing edge (MCE) or the secondary closing edge (SCE). Two modules are required in order to combine these safety functions (MCE/SCE).	○	○	–
Program switch (MS) expansion module Used to connect a conventional program switch (mode switch/MS) that is not based on CAN-bus technology. Only one module can be used at a time.	○	○	–

○ optional – not extendable

- 01 Battery
- 02 Door Pilot interface
- 03 Expansion modules
- 04 Drive unit
- 05 Power supply unit

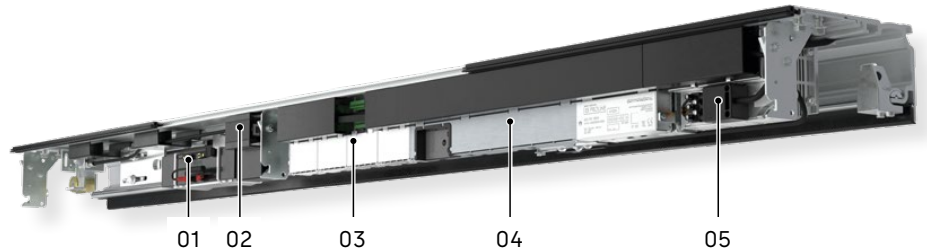

Technical data for sliding door operators

Door parameters	Standard sliding door			Escape route sliding door	
	ES 250 PRO	ES 400 PRO	ES 250 PRO EASY	ES 250 PRO FST	ES 400 PRO FST
Min. operator length	2 LW	2 LW	2 LW	2 LW	2 LW
Operator depth in mm	180	180	180	180	180
Operator height in mm	100	100	100	100	100
Use in escape routes and emergency exits	-	-	-		
Force limitation in accordance with EN 16005/DIN 18650	●	●	●	●	●
Operating noise	<47 dB(A)	<47 dB(A)	<47 dB(A)	<47 dB(A)	<47 dB(A)
Settings					
Opening speed (adjustable in increments)	10 – 70 cm/s	10 – 90 cm/s	10 – 70 cm/s	ca. 20 – 70 cm/s	ca. 20 – 90 cm/s
Closing speed (adjustable in increments)	10 – 70 cm/s	10 – 90 cm/s	10 – 70 cm/s	10 – 70 cm/s	10 – 90 cm/s
Low speed OPEN	0 – 9 cm/s	0 – 9 cm/s	–	0 – 9 cm/s	0 – 9 cm/s
Low speed CLOSE	3 – 9 cm/s	3 – 9 cm/s	–	3 – 9 cm/s	3 – 9 cm/s
Hold-open time, night/bank hold-open time	0 – 180 s	0 – 180 s	0 – 180 s	0 – 180 s	0 – 180 s
Night/bank opening delay	0 – 10 s	0 – 10 s	–	0 – 10 s	0 – 10 s
Partial opening	25 – 300 cm	25 – 300 cm	25 – 300 cm	25 – 300 cm	25 – 300 cm
Low-speed travel OPEN/CLOSE	0 – 30 cm	0 – 30 cm	0 – 30 cm	0 – 30 cm	0 – 30 cm
Power supply					
Supply voltage	230 V, 50/60 Hz	230 V, 50/60 Hz	230 V, 50/60 Hz	230 V, 50/60 Hz	230 V, 50/60 Hz
Power consumption	130 W	180 W	130 W	130 W	180 W
On-site line fuse	10 A	10 A	10 A	10 A	10 A
Degree of protection	IP 20	IP 20	IP 20	IP 20	IP 20
Power supply for peripheral equipment under network conditions	24 V DC/2A	24 V DC/2A	27 V DC/1A	24 V DC/2A	24 V DC/2A
Power supply for peripheral equipment in the event of a power failure (battery operation)	Optional 21–27 V DC/2A	Optional 21–27 V DC/2A	Optional 21–27 V DC/1A	21–27 V DC/2A	21–27 V DC/2A
Temperature range	-20 – +60 °C	-20 – +60 °C	-20 – +60 °C	-20 – +60 °C	-20 – +60 °C
Permissible air humidity (relative) (non-condensing)	max. 93 %	max. 93 %	max. 93 %	max. 93 %	max. 93 %
Standardisation and testing					
Compliant with the Low Voltage Directive and the EMC Directive	●	●	●	●	●
Monitoring of secondary closing edges verified to fulfil German standard DIN 18650 and EN 16005.	●	●	●	●	●
Manufactured to ISO 9001	●	●	●	●	●
Environmental product declaration according to ISO 14025; declaration holder: Institut Bauen und Umwelt e.V.	●	●	●	●	●

- 01 Battery
- 02 Door Pilot interface
- 03 Expansion modules
- 04 Drive unit
- 05 Power supply unit

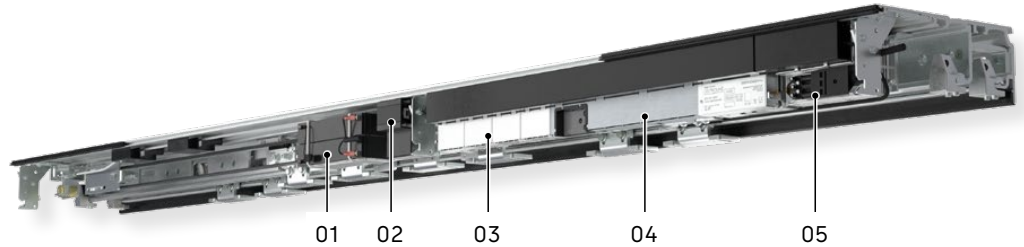

Technical data for telescopic sliding door operators

Door parameters	Standard sliding door			Escape route sliding door	
	ES 250 PRO T	ES 400 PRO T	ES 250 PRO T EASY	ES 250 PRO FST	ES 400 PRO FST
Min. operator length	1,5 LW+100	1,5 LW+100	1,5 LW+100	1,5 LW+100	1,5 LW+100
Operator depth in mm	252	252	252	252	252
Operator height in mm	100	100	100	100	100
Use in escape routes and emergency exits	-	-	-		
Force limitation in accordance with EN 16005/DIN 18650	●	●	●	●	●
Operating noise	<47 dB(A)	<47 dB(A)	<47 dB(A)	<47 dB(A)	<47 dB(A)
Settings					
Opening speed (adjustable in increments)	10 – 70 cm/s	10 – 90 cm/s	10 – 70 cm/s	ca. 20 – 70 cm/s	ca. 20 – 90 cm/s
Closing speed (adjustable in increments)	10 – 70 cm/s	10 – 90 cm/s	10 – 70 cm/s	10 – 70 cm/s	10 – 90 cm/s
Low speed OPEN	0 – 9 cm/s	0 – 9 cm/s	–	0 – 9 cm/s	0 – 9 cm/s
Low speed CLOSE	3 – 9 cm/s	3 – 9 cm/s	–	3 – 9 cm/s	3 – 9 cm/s
Hold-open time, night/bank hold-open time	0 – 180 s	0 – 180 s	0,5 – 30 s	0 – 180 s	0 – 180 s
Night/bank opening delay	0 – 10 s	0 – 10 s	–	0 – 10 s	0 – 10 s
Partial opening	25 – 400 cm	25 – 400 cm	25 – 400 cm	25 – 400 cm	25 – 400 cm
Low-speed travel OPEN/CLOSE	0 – 30 cm	0 – 30 cm	0 – 30 cm	0 – 30 cm	0 – 30 cm
Power supply					
Supply voltage	230 V, 50/60 Hz	230 V, 50/60 Hz	230 V, 50/60 Hz	230 V, 50/60 Hz	230 V, 50/60 Hz
Power consumption	130 W	180 W	130 W	130 W	180 W
On-site line fuse	10 A	10 A	10 A	10 A	10 A
Degree of protection	IP 20	IP 20	IP 20	IP 20	IP 20
Power supply for peripheral equipment under network conditions	24 V DC/2A	24 V DC/2A	27 V DC/1A	24 V DC/2A	24 V DC/2A
Power supply for peripheral equipment in the event of a power failure (battery operation)	Optional 21–27 V DC/2A	Optional 21–27 V DC/2A	Optional 21–27 V DC/1A	21–27 V DC/2A	21–27 V DC/2A
Temperature range	-20 – + 60 °C	-20 – + 60 °C	-20 – + 60 °C	-20 – + 60 °C	-20 – + 60 °C
Permissible air humidity (relative) (non-condensing)	max. 93 %	max. 93 %	max. 93 %	max. 93 %	max. 93 %
Standardisation and testing					
Compliant with the Low Voltage Directive and the EMC Directive	●	●	●	●	●
Monitoring of secondary closing edges verified to fulfil German standard DIN 18650 and EN 16005.	●	●	●	●	●
Manufactured to ISO 9001	●	●	●	●	●
Environmental product declaration according to ISO 14025; declaration holder: Institut Bauen und Umwelt e.V.	●	●	●	●	●

Connections with CAN-bus technology

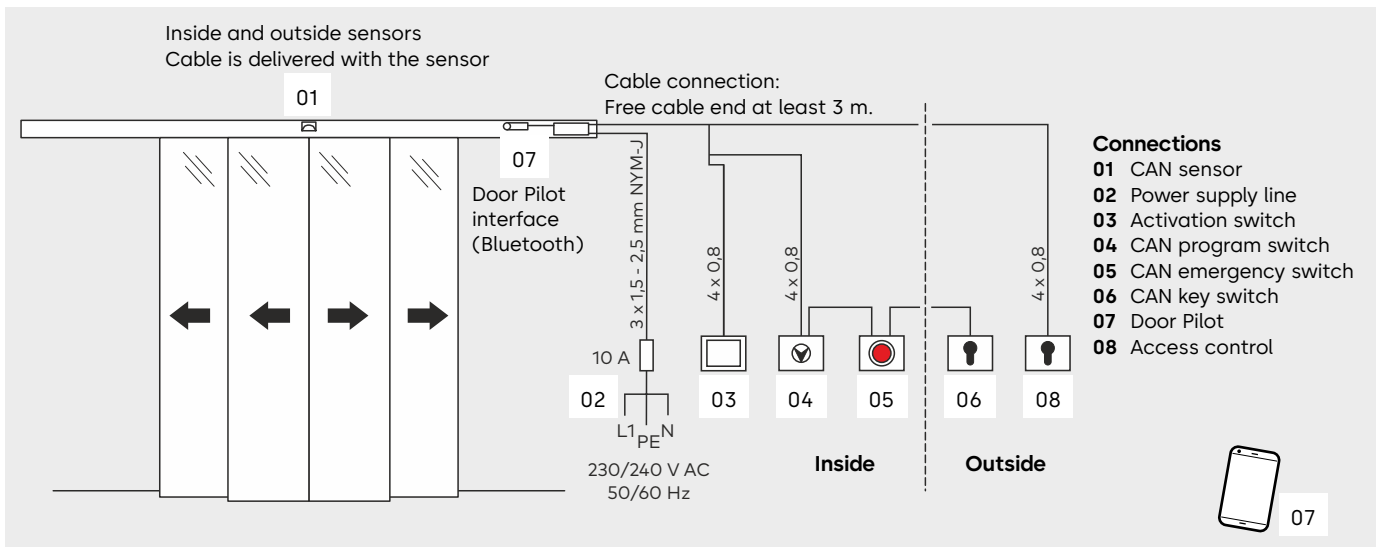

Conventional technology connections

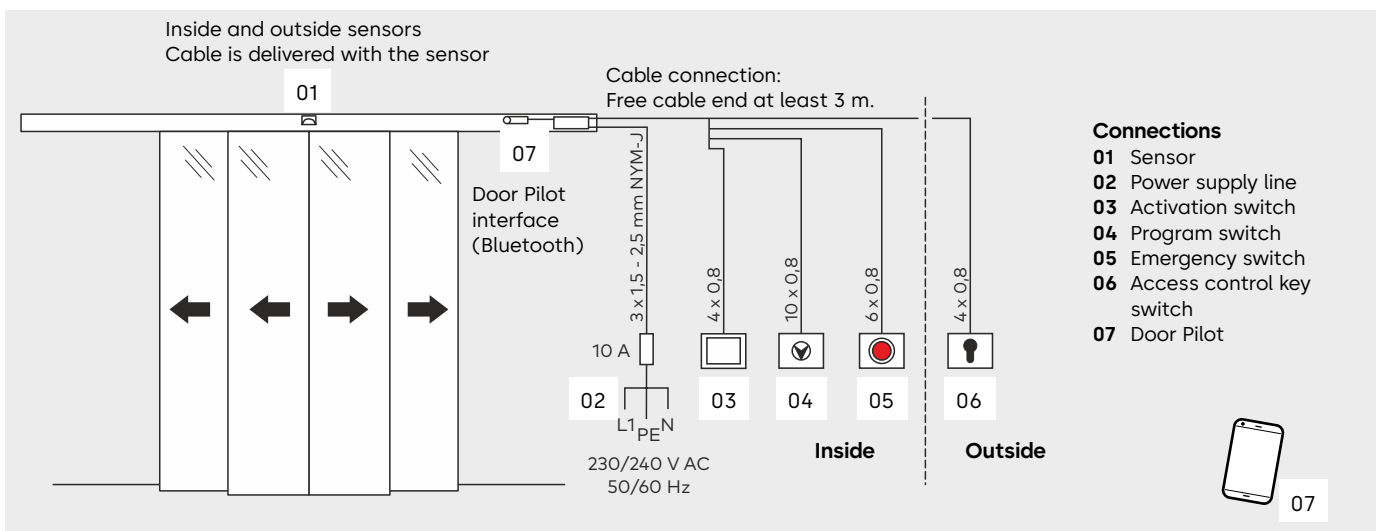



Door Pilot App

The dormakaba Door Pilot app allows automatic doors to be easily controlled from a smartphone. Operators from the ES PROLINE series can be equipped with the Door Pilot interface as an option. The app is available in iOS and Android versions and can be obtained from the respective app store.

Program switch functions

Use 6 different functions:

automatic	Opens from the inside and outside – perfect for normal opening hours.
Partial opening	Opens from the inside and outside with reduced opening width – ideal for cold winter days.
Output	Opens from the inside only – ideal for use shortly before closing time.
Permanent Open	Door is permanently open – suitable for deliveries or ventilation.
Off	Door remains closed (and perhaps locked) and can only be opened by changing the program switch position or by an externally controlled impulse.
Open-once	For easy opening in close proximity (not possible with the program switch in the "Off" position).

Door status signal contacts

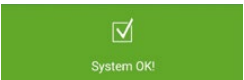
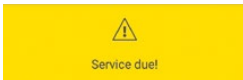
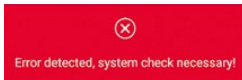
 System OK!	 Service due!	 Error detected, system check necessary!
System OK	Maintenance due	Fault detected, service due

Customer benefits

- Complement to the program switch, convenient operation from a smartphone.
- Check functions easily without needing specialist knowledge.
- No need to incorporate into existing building network.
- Direct contact function for simplified/direct access to dormakaba Service.

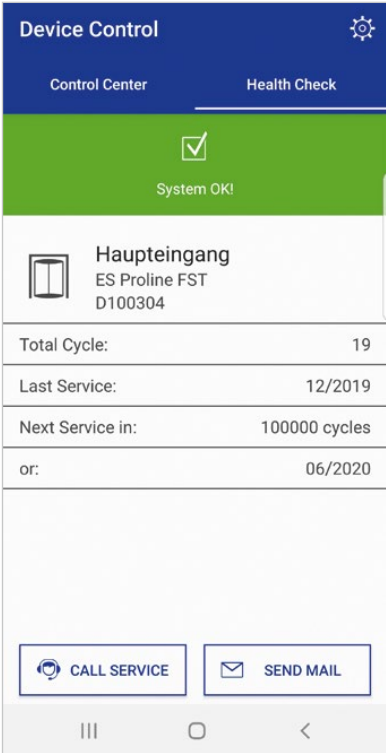
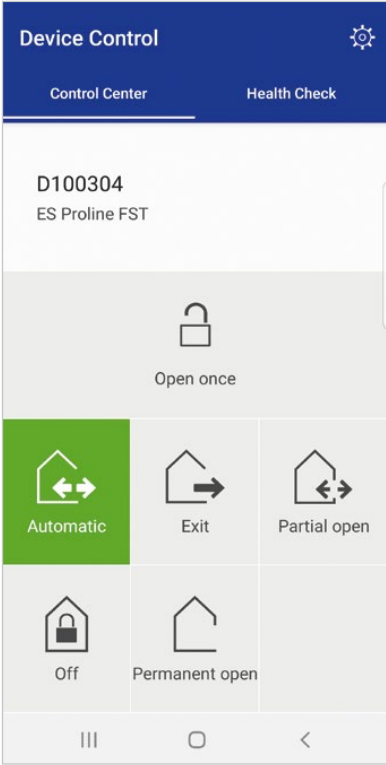

Wide range of accessories from dormakaba

Program switches

When combined with a program switch from the dormakaba accessories range, the automatic door system can satisfy all kinds of individual operating requirements and is easy to use. The program switches have been designed in various versions and for a wide range of requirements. The options range from mechanical to fully electronic versions

locked by your choice of profile cylinders, round cylinders or fully electronic coding.

- Up to 5 different functions: Off, automatic, exit only, partially open, permanent open
- Electronic program switches in System 55 design for the most discerning aesthetic demands

**For sliding door operators without escape route
and emergency exit requirements**

Article no.

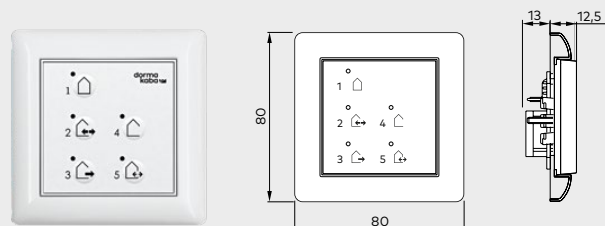

EPS fully electronic program switch

System 55 design, 5 positions, lockable using coding or additional TL-ST S55 key switch, membrane keypad, concealed, 80 x 80 mm

EPS, with frame	white	16556901150
EPS CAN, without frame	white	16712501150
Box for surface mounting		5226933332
EPS CAN (44 x 50 mm)		16712401150

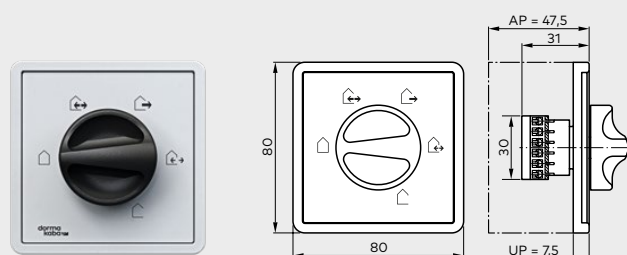

PG-S1 program switch

5 positions, aluminium, concealed, 80 x 80 x 40 mm

PG-S1	white, Gira S-Color	19135401150
Box for surface mounting		5227033332

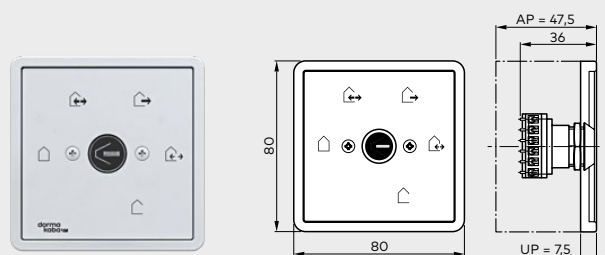

PG-S2 program switch

5 positions, lockable, aluminium, concealed, 80 x 80 x 40 mm

PG-S2	white, Gira S-Color	19135602150
Box for surface mounting		5227033332

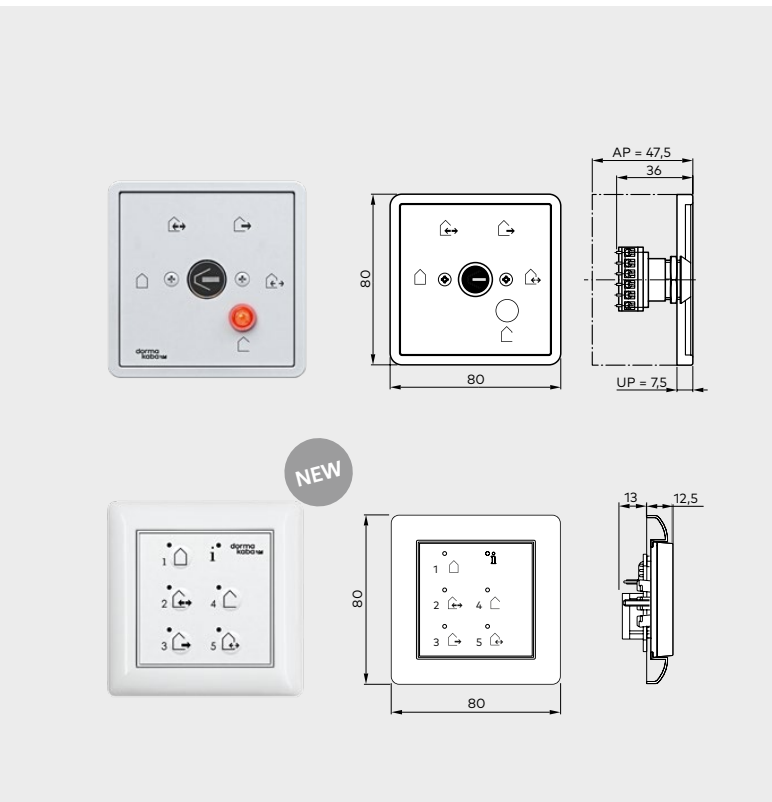

For sliding door operators in escape routes and emergency exits

Article no.

PG-FST1 program switch

5 positions, lockable, aluminium, concealed, 80 x 80 x 40 mm

PG-FST1	white, Gira S-Color	19135603150
Box for surface mounting		5227033332

EPS-FST fully electronic program switch

System 55 design, 5 positions, lockable using coding or additional TL-ST S55 key switch, membrane keypad, concealed, 80 x 80 mm

EPS-FST, with frame	white	16556801150
EPS CAN, without frame	white	16712501150
Box for surface mounting		5226933332

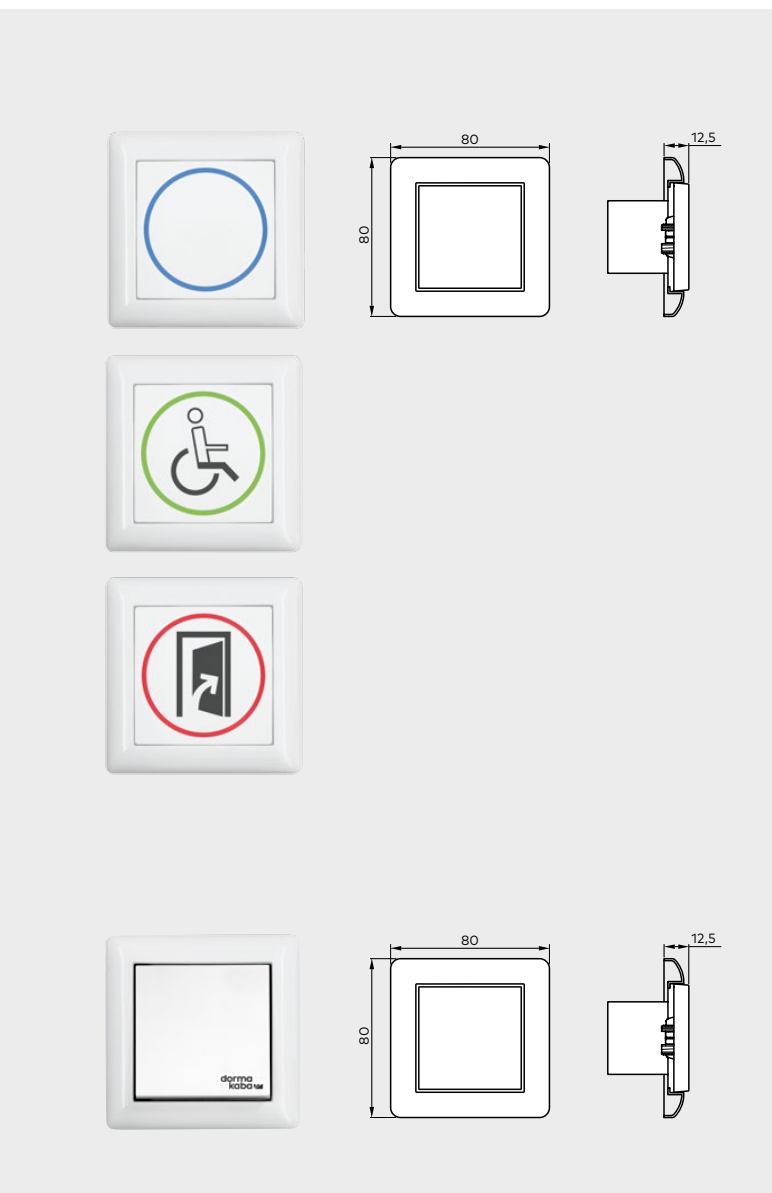

Activation switches

Article no.

CleanSwitch

contactless radar push-button, System 55, flush-mounted, detection zone adjustable 10 - 50 cm, dimensions: 80 x 80 x 40 mm, switch insert 55 x 55 mm, colour: white

CleanSwitch	neutral	16737401170
	wheelchair	16737501170
	door open	16737601170

Manual release switch

Single-pole change-over contact, single frame, concealed, System 55

Manual release switch	white	19144701170
-----------------------	-------	-------------



Key switch

Article no.

KT 3-1

1 NO contact with Europrofile half-cylinder in line with DIN 18252, half 30–32.5 mm, length 40.5–43.5 mm, locking cam position left (90°) (interchangeable with master-key system half-cylinder), key can only be removed in neutral position, aluminium, metal, 75 x 75 x 60 mm, flush-mounted version incl. flush-mounted box, diameter 59 mm x 50 mm deep

KT 3-1 UP	Concealed	05054531332
KT 3-1 AP	Surface-mounted	05054631332

KT 8

Labelled "Open"/"Closed", 2 NO contacts with Europrofile half-cylinder in line with DIN 18252, half 30–32.5 mm, length 40.5–43.5 mm, locking cam position left (90°) (interchangeable with master-key system half-cylinder), key can only be removed in neutral position, aluminium, metal, 75 x 75 x 60 mm

KT 8 UP	Concealed	05054831332
KT 8 AP	Surface-mounted	05054931332

TL-ST S55

Push button with single-pole changeover contact for on-site Europrofile half-cylinder in line with DIN 18252, half 30–32.5 mm, length 40.5–43.5 mm, locking cam position left (90°), with cover for System 55, not suitable for surface-mounted boxes, without Europrofile half-cylinder, without frame.

TL-ST S55 W	white	56330710
TL-ST S55 S	silver	56330701
TL-ST S55 A	anthracite	56330715

KT 3-2

1 NO contact with Europrofile half-cylinder, interchangeable with master-key system half cylinder, key can only be removed in neutral position, cover panel for replacement, labelled "Open"/"Closed", aluminium, concealed: 125 x 100 mm, surface-mounted: 70 x 90 mm

KT 3-2	05054731332
--------	-------------

Key switch CAN

Switch with single-pole changeover contact, with Europrofile half-cylinder in line with DIN 18252, half 30–32.5 mm, length 40.5–43.5 mm, locking cam position left (90°) (interchangeable with master-key system half-cylinder), with cover for System 55, not suitable for surface-mounted boxes, without frame.

Key switch CAN	16715801150
----------------	-------------

LED touch key

Article no.

LED touch key

Manual actuator with plastic frame in white, similar to RAL 9016 and traffic grey similar to RAL 7043

LED touch key	16672601170
---------------	-------------

LED hygienic touch key

Manual actuator, tempered glass encapsulated, glass button surface, hygienic version in line with EN 1672-1/2

LED touch key	16672901170
---------------	-------------



Emergency activation buttons

Article no.



Emergency switch CAN

CAN-bus emergency activation button, red knob (emergency activation button off) or green knob (emergency open), System 55, without frame.

Emergency switch CAN, red	16718501150
Emergency switch CAN, green	16718502150

TL-N S55 conventional

The area around the emergency button is brightly illuminated and has a visual display of the locking status, an acoustic and visual alarm siren, is tamper-protected under glass, one NO contact and one NC contact, concealed, 80 x 80 mm, System 55, without frame

TL-N S55	56330500
----------	----------

Conventional emergency switch

Emergency activation button (Emergency Off function with red knob and Emergency Open function with green knob) with yellow central plate

NAT 1	One NO contact and one NC contact, white frame, concealed, 80 x 80 mm, System 55	90400025
NAT 2	Emergency Open version with green knob, white frame, concealed, 80 x 80 mm, System 55	90400035
NAT 4	One NO and one NC contact, surface-mounted 68 x 68 mm Concealed	05027031332

Cover frame for buttons and switches

Article no.



Standard System 55

FR-S55 1	Single frame, white, 80.7 x 80.7	56391110
FR-S55 2	Double frame, white, 151.8 x 80.7	56391210
FR-S55 3	Triple frame, white, 223.3 x 80.7	56391310

E2 System 55 (not shown)

FR-E2W 1	Single frame, E2 55, white, 80.8 x 80.8	56392110
FR-E2W 2	Double frame, E2 55, white, 151.9 x 80.8	56392210
FR-E2W 3	Triple frame, E2 55, white, 223.4 x 80.8	56392310
FR-E2S 1	Single frame, E2 55, silver, 80.8 x 80.8	56392101
FR-E2S 2	Double frame, E2 55, silver, 151.9 x 80.8	56392201
FR-E2S 3	Triple frame, E2 55, silver, 223.4 x 80.8	56392301
FR-E2A 1	Single frame, E2 55, anthracite, 80.8 x 80.8	56392115
FR-E2A 2	Double frame, E2 55, anthracite, 151.9 x 80.8	56392215
FR-E2A 3	Triple frame, E2 55, anthracite, 223.4 x 80.8	56392315

Active infrared sensor and combined sensors

Article no.



Combined sensor IXIO-DT1

Combined sensor featuring radar detector with direction recognition and safety curtain for non-escape route systems, width 270 mm

IXIO-DT1	black	86800001
	silver	86800002
	white	86800003

Combined sensor IXIO-DT3

Combined sensor featuring self-monitored radar detector with direction recognition and safety curtain for escape route systems, width 270 mm

IXIO-DT3	black	86800004
	silver	86800005
	white	86800006

Safety curtain IXIO-ST

Safety curtain (tested) IXIO-ST for monitoring closing edges, width 270 mm

IXIO-ST	black	86800010
	silver	86800011
	white	86800012



Combined sensor IXIO-D CAN

Combined sensor featuring radar detector with direction recognition and safety curtain for escape route systems and non-escape route systems (CAN-bus technology), width 270 mm

IXIO-D CAN	black	86800053
	silver	86800057
	white	86800056

Safety curtain IXIO-S CAN

Safety curtain (tested) IXIO-S CAN for monitoring closing edges (CAN-bus technology), width 209 mm

IXIO-S CAN	black	86800055
	silver	86800059
	white	86800058

Integrated combined sensor IXIO-D CAN

Combined sensor (without cover) featuring self-monitored radar detector with direction recognition and safety curtain for escape route and non-escape route systems for integration into the sensor casing.

Integrated IXIO-D CAN	86800050
-----------------------	----------

Integrated safety curtain IXIO-S CAN

IXIO-S CAN safety curtain (tested, without cover) for monitoring closing edges (CAN-bus technology), for integration into the sensor casing.

Integrated IXIO-S CAN	86800052
-----------------------	----------

Accessories for active infrared sensor and combined sensors

Article no.



Ceiling installation set

Ceiling installation system for IXIO-DT, IXIO-S, IXIO-D-CAN and IXIO-S-CAN, housing width 270 mm or 209 mm

Ceiling installation set	black	86800019
	white	86800020

Rain protection cover

Rain protection cover for IXIO-DT, IXIO-ST, IXIO-D-CAN and IXIO-S-CAN, housing width 209 mm or 270 mm

Rain protection cover	black	86800021
-----------------------	-------	----------

Fixing bracket

Fixing bracket for IXIO sensor

Fixing bracket for housing width 270 mm	black	86800016
Fixing bracket for housing width 209 mm	black	86800018

Our Sustainability Commitment

We are committed to foster a sustainable development along our entire value chain in line with our economic, environmental and social responsibilities toward current and future generations. Sustainability at product level is an important, future-oriented approach in the field of construction. In order to give quantified disclosures of a product's environmental impact through its entire life cycle, dormakaba provides Environmental Product Declarations (EPD), based on holistic life cycle assessments.

www.dormakaba.com/sustainability



Our offering

Access Automation Solutions

Entrance Automation
Entrance Security



Access Control Solutions

Electronic Access & Data
Escape and Rescue Systems
Lodging Systems



Access Hardware Solutions

Door Closers
Architectural Hardware
Mechanical Key Systems



Services

Technical Support
Installation and commissioning
Maintenance and Repair



Key & Wall Solutions

Key Systems
Movable / Sliding Walls



Safe Locks

Electronic Safe Locks
Mechanical Safe Locks
Boltworks and Accessories



Glass systems

Manual door systems
Glass fittings
Horizontal Sliding Walls



WN 05592851532, EN, 10/2025
Subject to technical modifications.



dormakaba.com

dormakaba
International Holding AG
Hofwissenstrasse 24
CH-8153 Rümlang
T +41 44 818 90 11
info@dormakaba.com
dormakaba.com