

ES PROLINE

Automatic sliding door operators





Table of contents

ES PROLINE	
The new generation of sliding door operators	4
Data and features	6
Sliding door operators with and without FST escape route function	
System dimensions and max. door leaf weight	8
Technical data for sliding door operators	9
Header profiles	10
Schematic illustration of door cross-section	10
Connections with CAN-bus technology	11
Conventional technology connections	11
Telescopic sliding door operators with and without FST escape route function	
System dimensions and max. door leaf weight	12
Technical data for telescopic sliding door operators	13
Header profiles	14
Schematic illustration of door cross-section	14
Connections with CAN-bus technology	15
Conventional technology connections	15
Locking devices	16
Casing variants	17
Master controller functions and optional expansion module functions	18
Door Pilot App	19
Accessories	
Program switches	20
Activation switches	21
Key switch	22
LED touch key	22
Emergency activation buttons	23
Cover frame for buttons and switches	23
Active infrared sensor and combined sensors	24
Accessories for active infrared sensor and combined sensors	25

ES PROLINE

The new generation of sliding door operators – powerful, quick and networked.

The new ES PROLINE drive system for automatic sliding doors is the ideal solution in almost all applications and areas of use. It features many enhanced functions and attributes compared to the previous drive system. The modular structure of the system enables it to be used with classic sliding doors, sliding doors with escape route functions and with telescopic sliding doors.

The ES PROLINE is a sound investment for the future. This drive system addresses current topical issues such as sustainability and digitisation. The ES PROLINE also complies with the current European and German standards and safety regulations DIN 18650 and EN 16005.

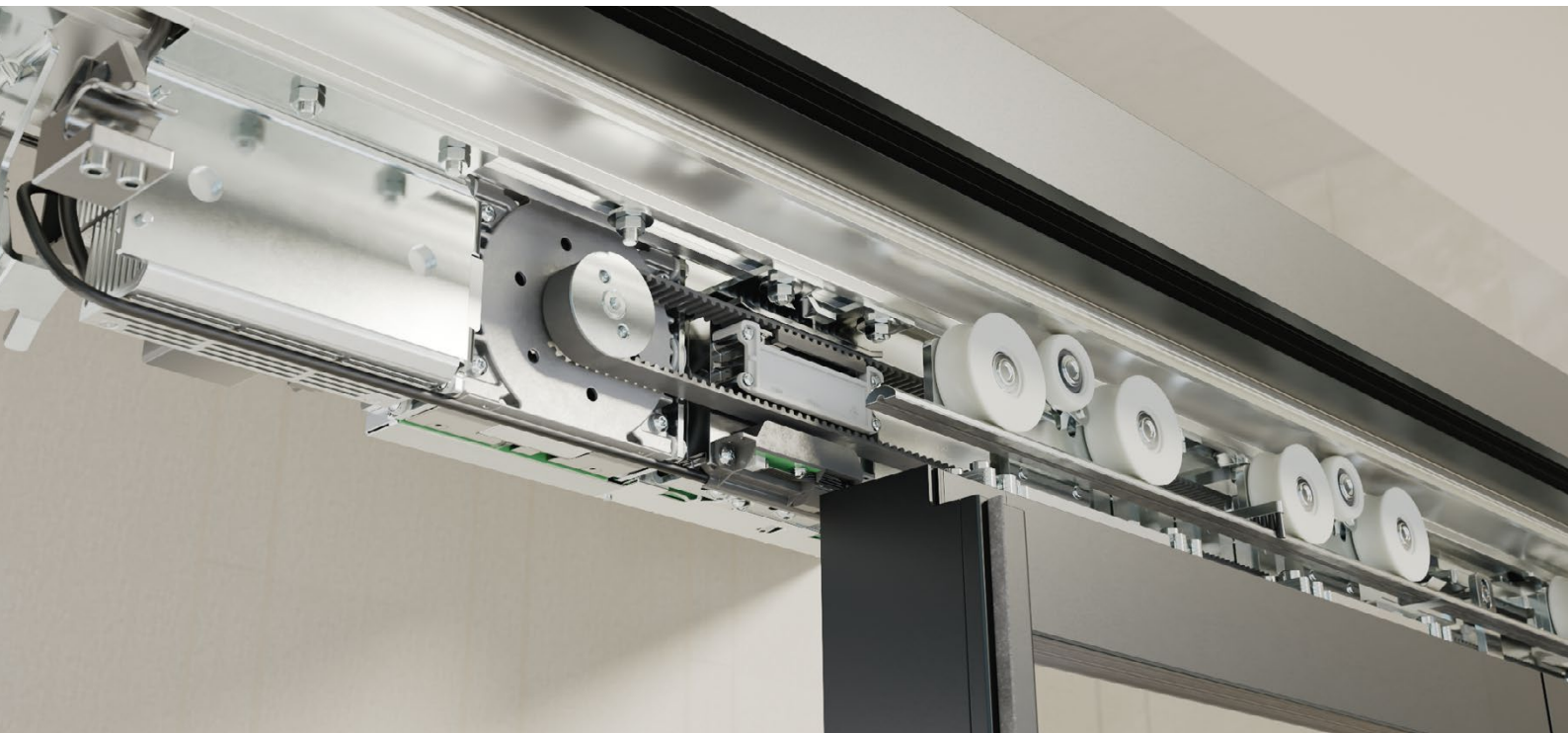

Powerful

The ES PROLINE is equipped with modern dormakaba Direct Drive motor technology for the dynamic opening and closing of sliding doors. The drive version ES 500 PRO can be used to achieve door leaves with a weight of up to 2 x 250 kg.



Durable

Verified dormakaba quality is the goal of the ES PROLINE. This drive system successfully passed tests involving **1.5 million opening and closing cycles**. This extends the service life of doors by 50%.



Quick

The ES PROLINE opens and closes automatic sliding doors swiftly. This ensures a smooth flow of users even in areas with a high volume of traffic. It also contributes to reducing energy losses caused by open doors.

ES PRO for sliding door systems ST

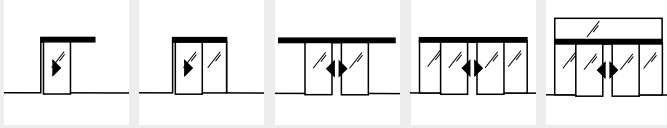

ES PRO T for telescopic sliding door systems TST

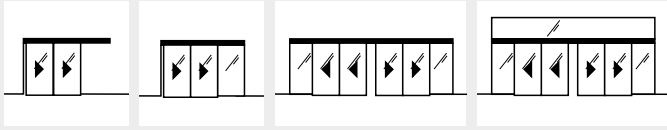

Modular

The adaptable ES PROLINE can be used to satisfy varying requirements for automatic sliding doors.

The modular kit can be universally combined with standard doors, escape route doors and telescopic sliding doors.

Converting existing systems (dormakaba ES 200) is quite straightforward.

ES PROLINE EASY

Entry-level solution with a Direct Drive Unit (DDU).

ES PROLINE

For standard sliding doors with a door leaf weight of up to 2 x 250 kg and optional expansion modules.

ES PROLINE FST

For sliding doors used on escape routes with door leaves weighing up to 2 x 200 kg and optional expansion modules.

NEW
for door leaf
weight up to
2 x 250 kg
ES 500 PRO



Sustainable

The ES PROLINE modular system is economical and utilises dormakaba Direct Drive motor technology. In addition, the packaging material is 100% recyclable.



Quiet

Its gearless motor means that the ES PROLINE opens and closes sliding doors extremely quietly. Making it ideal for use in applications particularly sensitive to noise.



Connected

The ES PROLINE drive can be equipped with a module that enables it to be controlled by an app. The app also provides useful additional information and a direct link to dormakaba Service.

ES PROLINE

Data and features

Control module	ES 250 PRO ES 400 PRO ES 500 PRO ES 250 PRO T ES 400 PRO T	ES 250 PRO FST ES 400 PRO FST ES 250 PRO T FST ES 400 PRO T FST	ES 250 PRO EASY ES 250 PRO T EASY
Modular design	●	●	●
Function programs	●	●	●
– Off	●	●	●
– Automatic	●	●	●
– Permanent open	●	●	●
– Partial open	●	●	●
– Exit	●	●	●
Automatic reversing	●	●	●
Connection for securing the passageway (on both sides)	●	●	●
Tested in accordance with EN 16005/DIN 18650	●	●	●
Securing main and secondary closing edge(s) according to EN 16005/DIN 18650	●	●	●
Basic parameters set using integrated display and buttons	●	●	●
Parameterisation via Operator Service Interface (OSI)	●	●	●
Door Pilot interface (Bluetooth)	○	○	○
Automatic opening/closing in the event of a power failure (if a battery set is used)	●/●	●/– (Battery set supplied as standard)	●/●
Emergency battery operation (if a battery set is used)	●	–	●
24 V DC output for accessories	●	●	●
Readable fault memory with fault codes	●	●	●
CAN interface for connecting a program switch	●	●	●
CAN interface for connecting additional CAN-bus components	●	●	–
Multiports for connecting accessory components	4	4	2
Functions*			
Pharmacy function	●	●	–
Door status signal contacts	●	●	●
Panic closing (observe regional regulations!)	●	●	–
Door bell contact	●	●	–
Airlock control	●	–	–
Synchronous operation	●	●	–
Safety deactivation	●	●	–
Night/bank function	●	●	●
Emergency open	–	●	–
Emergency stop	●	–	–
Configurable partial opening distance	●	●	●
Slide and Go	●	●	–
Close/open on malfunction	●	●	–
Fire service switch function	●	●	–

*The functions can be implemented by the master controller or by the 4 I/O modules. For further information, see page 18

	ES 250 PRO ES 400 PRO ES 500 PRO ES 250 PRO T ES 400 PRO T	ES 250 PRO FST ES 400 PRO FST ES 250 PRO T FST ES 400 PRO T FST	ES 250 PRO EASY ES 250 PRO T EASY
Control module			
Safety and activation (SIK) expansion module**			
For connecting conventional (not CAN-bus-capable) safety and activation sensors	○	○	-
Program switch (MS) expansion module**			
For connecting conventional (not CAN-bus-capable) program switches	○	○	-
Auxiliary equipment			
Electro-mechanical belt locking device	○	○	○
Manual lock release for electro-mechanical locking device	○	○	○
Magnetic locking device, jam-free	○	○	-
Electromotive hook locking device (up to RC3)	○	○	-
Manual lock release for electromotive locking device	○	○	-
Battery set	○	●	○
Emergency power supply UPS (external)	○	○	○
Module for connection to LON/LAN building control systems	○	○	-
Potential-free relay contact	○	○	○

● as standard ○ optional

**Further information on the expansion modules can be found on page 18



Sliding door operators

with and without FST escape route function



The innovative ES PROLINE sliding door drive system can be used for classic single-leaf or double-leaf sliding door applications without a hitch. It can also be used on escape route and emergency exit doors, as well as with particularly heavy door leaves.

System dimensions and max. door leaf weight

Door parameters	1-leaf			2-leaf		
	ES 250 PRO ES 250 PRO FST ES 250 PRO EASY	ES 400 PRO ES 400 PRO FST	ES 500 PRO	ES 250 PRO ES 250 PRO FST ES 250 PRO EASY	ES 400 PRO ES 400 PRO FST	ES 500 PRO
Max. door leaf weight	1 x 125 kg	1 x 250 kg	1 x 400 kg	2 x 125 kg	2 x 200 kg	2 x 250 kg
Clear passage width LW*	700 – 3000 mm		850 – 3000 mm	800 – 3000 mm		1650 – 3000 mm
Clear passage height LH	2000 – 3000 mm		2000 – 3000 mm	2000 – 3000 mm		2000 – 3000 mm

Estimated door leaf weight

Door leaf weight $\frac{LH [m] \times LW [m] \times \text{weight of glass [kg/m}^2]}{\text{Number of door leaves}}$

Normal glass weights: 10 mm glass thickness e.g. toughened safety glass 10: 25 kg/m², 12 mm glass thickness e.g. double glazing 22, 2 x laminated safety glass 6: 30 kg/m²

*The minimum clear passage width for escape route sliding doors is specified in the relevant regional building codes and may vary. The maximum practicable dimensions are subject to the respective door plans and door requirements and also depend on the selected profile system.

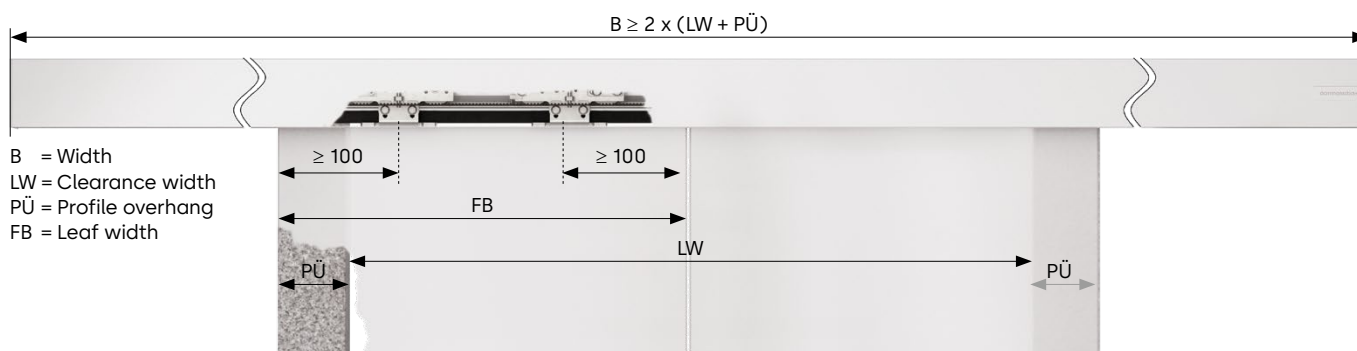

B = Width
 LW = Clearance width
 PÜ = Profile overhang
 FB = Leaf width

Escape route sliding doors are only approved if installed with type-approved dormakaba profile systems.

- 01 Battery
- 02 Door Pilot interface
- 03 Expansion modules
- 04 Drive unit
- 05 Power supply unit

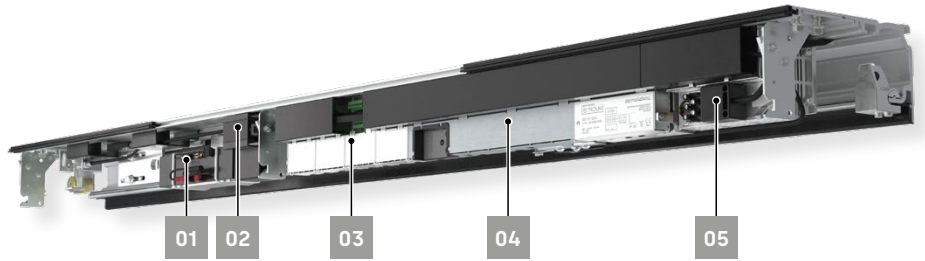

Technical data for sliding door operators

Door parameters	Standard sliding door				Escape route sliding door	
	ES 250 PRO EASY	ES 250 PRO	ES 400 PRO	ES 500 PRO	ES 250 PRO FST	ES 400 PRO FST
Min. operator length	2 LW	2 LW	2 LW	2xFB+250 mm	2 LW	2 LW
Operator height/depth in mm	100 / 180	100 / 180	100 / 180	150 / 180	100 / 180	100 / 180
Use in escape routes and emergency exits	-	-	-	-		
Force limitation in accordance with EN 16005/DIN 18650	●	●	●	●	●	●
Operating noise	<47 dB(A)	<47 dB(A)	<47 dB(A)	<47 dB(A)	<47 dB(A)	<47 dB(A)

Settings

Opening speed (adjustable in increments)	10 – 70 cm/s	10 – 70 cm/s	10 – 90 cm/s	10 – 70 cm/s	ca. 20 – 70 cm/s	ca. 20 – 90 cm/s
Closing speed (adjustable in increments)	10 – 70 cm/s	10 – 70 cm/s	10 – 90 cm/s	10 – 70 cm/s	10 – 70 cm/s	10 – 90 cm/s
Low speed OPEN	–	0 – 9 cm/s	0 – 9 cm/s	0 – 9 cm/s	0 – 9 cm/s	0 – 9 cm/s
Low speed CLOSE	–	3 – 9 cm/s	3 – 9 cm/s	3 – 9 cm/s	3 – 9 cm/s	3 – 9 cm/s
Night/bank opening delay	–	0 – 10 s	0 – 10 s	0 – 10 s	0 – 10 s	0 – 10 s
Partial opening	25 – 300 cm	25 – 300 cm	25 – 300 cm	25 – 300 cm	25 – 300 cm	25 – 300 cm
Hold-open time, night/bank hold-open time	0 – 180 s	0 – 180 s	0 – 180 s	0 – 180 s	0 – 180 s	0 – 180 s
Low-speed travel OPEN/CLOSE	0 – 30 cm	0 – 30 cm	0 – 30 cm	0 – 30 cm	0 – 30 cm	0 – 30 cm

Standardisation and testing

All door operators in the ES PROLINE and ES PROLINE FST series are standardised and tested:

- Compliant with the Low Voltage Directive and the EMC Directive
- Monitoring of secondary closing edges verified to fulfil German standard DIN 18650 and EN 16005.
- Manufactured to ISO 9001
- Environmental product declaration according to ISO 14025; declaration holder: Institut Bauen und Umwelt e.V.

Power supply

Supply voltage:	230 V, 50/60 Hz
Power consumption:	
- ES 250 PRO	130 W
- ES 400 PRO/ES 500 PRO	180 W
On-site line fuse:	10 A
Degree of protection:	IP 20
Power supply for peripheral equipment under network conditions:	
- ES 250 PRO, ES 400 PRO, ES 500 PRO	24 V DC/2A
- ES 250 PRO EASY	27 V DC/1A
Power supply for peripheral equipment in the event of a power failure (battery operation):	
- ES 250 PRO, ES 400 PRO, ES 500 PRO	Optional 21–27 V DC/2A
- ES 250 PRO EASY	Optional 21–27 V DC/1A
- ES 250 PRO FST, ES 400 PRO FST	21–27 V DC/2A
Temperature range:	-20 – +60 °C
Permissible air humidity (relative, non-condensing):	max. 93 %

Header profiles

Profiles for 100 mm and 150 mm drive heights, for corridor or wall installation, enable the system to be adapted to all conceivable areas of application. The basic mechanical system has a low number of components and is the same for both drive heights.

**Profiles for corridor installation:
100 mm**

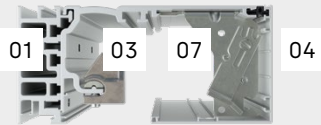

**Profiles for wall installation:
100 mm**

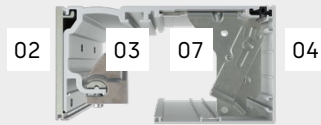

**Profiles for wall installation:
100 mm with sensor casing**

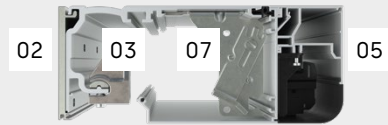

**Profiles for corridor installation:
150 mm**

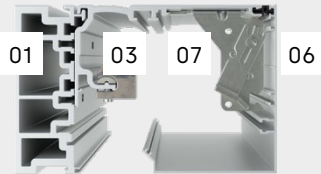

**Profiles for wall installation:
150 mm**

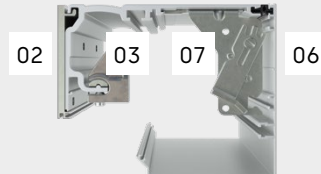

- 01 Aluminium girder
- 02 Mounting profile
- 03 Header profile
- 04 Internal casing for 100 mm drive height
- 05 Sensor casing for 100 mm drive height
- 06 Internal casing for 150 mm drive height
- 07 Cover bracket

Schematic illustration of door cross-section (operator and sliding panel)

Schematic illustration of door cross-section:
wall mounted, drive height 100 mm

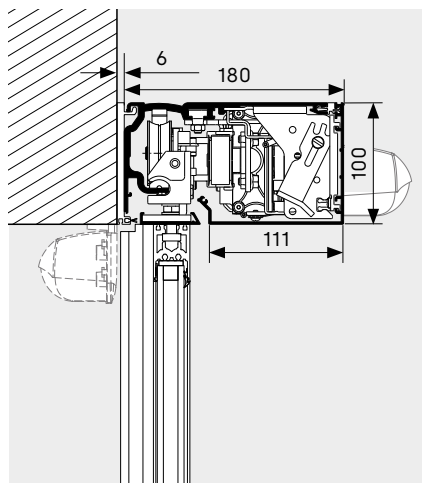

Schematic illustration of door cross-section:
wall mounted, drive height 150 mm

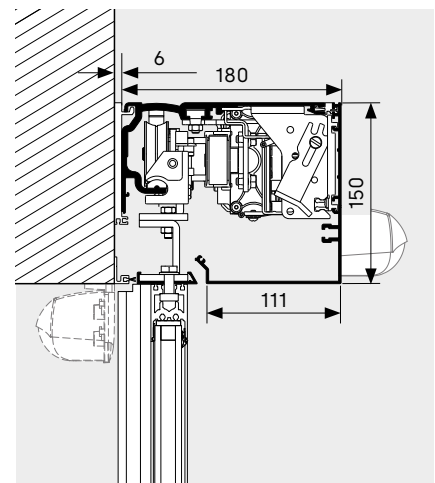
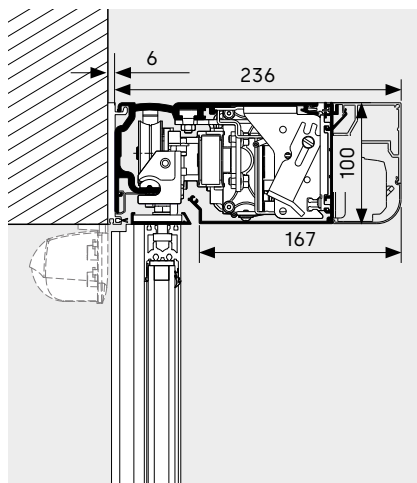

Connections with CAN-bus technology

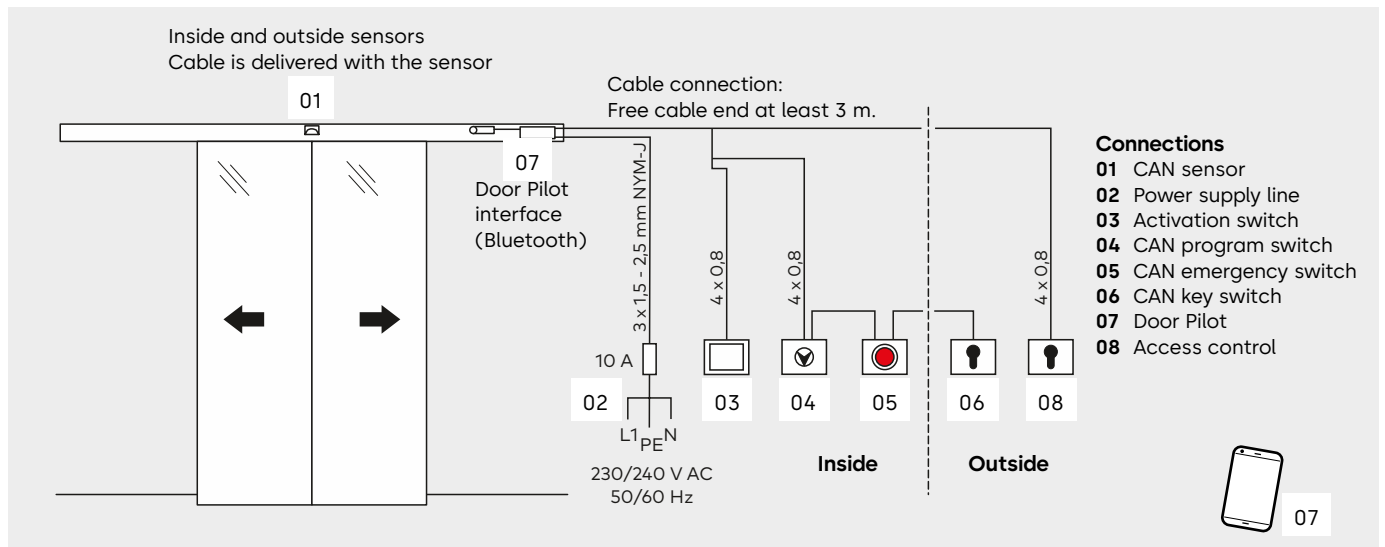

Conventional technology connections

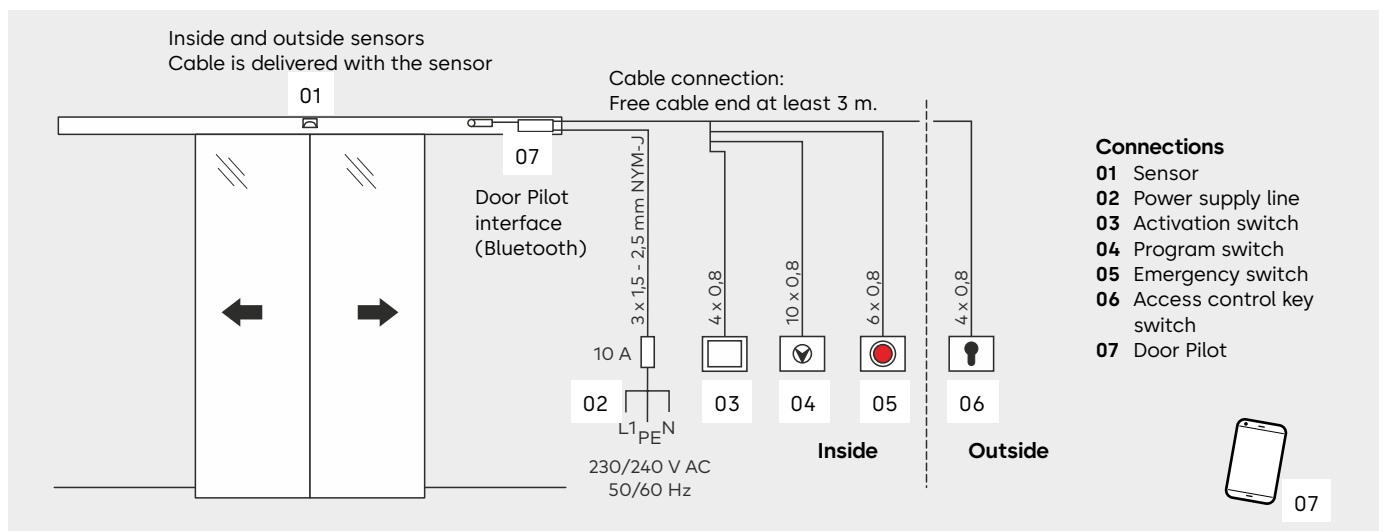

Telescopic sliding door operators

with and without FST escape route function



Automatic telescopic sliding door operators can be used to construct wide passageways with comparatively slim systems. And that is not the only reason they are so versatile: they can also be used for escape route and emergency exit doors with opening widths of up to 4000 mm.

System dimensions and max. door leaf weight

Door parameters	2-leaf		4-leaf	
	ES 250 PRO T ES 250 PRO T FST ES 250 PRO T EASY	ES 400 PRO T ES 400 PRO T FST	ES 250 PRO T ES 250 PRO T FST ES 250 PRO T EASY	ES 400 PRO T ES 400 PRO T FST
Max. door leaf weight	2 x 75 kg	2 x 100 kg	4 x 75 kg	4 x 100 kg
Clear passage width LW*	800 – 2400 mm		1400 – 4000 mm	
Clear passage height LH	2000 – 3000 mm		2000 – 3000 mm	

Estimated door leaf weight

Door leaf weight $\frac{LH [m] \times LW [m] \times \text{weight of glass [kg/m}^2]}{\text{Number of door leaves}}$

Normal glass weights: 10 mm glass thickness e.g. toughened safety glass 10: 25 kg/m², 12 mm glass thickness e.g. double glazing 22, 2 x laminated safety glass 6: 30 kg/m² A drive suspension is required from a leaf weight of 2 x 75 kg or 4 x 75 kg.

*The minimum clear passage width for escape route sliding doors is specified in the relevant regional building codes and may vary. The maximum practicable dimensions are subject to the respective door plans and door requirements and also depend on the selected profile system.

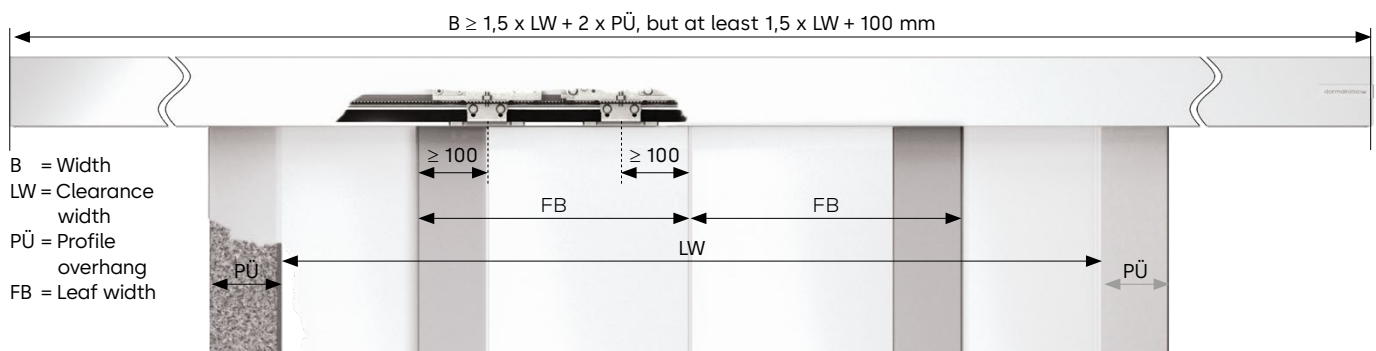

Escape route sliding doors are only approved if installed with type-approved dormakaba profile systems.

- 01 Battery
- 02 Door Pilot interface
- 03 Expansion modules
- 04 Drive unit
- 05 Power supply unit

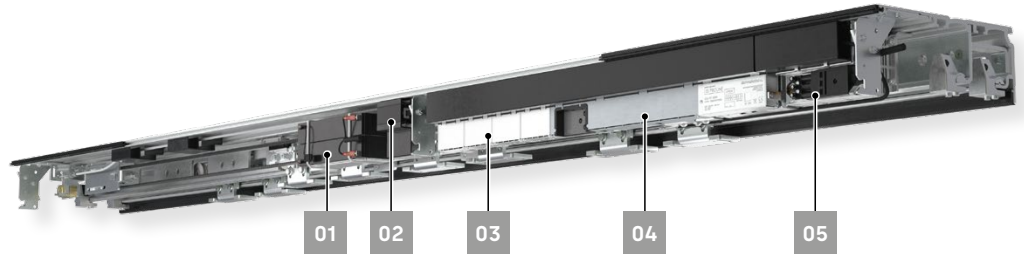

Technical data for telescopic sliding door operators

Door parameters	Standard sliding door			Escape route sliding door	
	ES 250 PRO T	ES 400 PRO T	ES 250 PRO T EASY	ES 250 PRO FST	ES 400 PRO FST
Min. operator length	1,5 LW+100	1,5 LW+100	1,5 LW+100	1,5 LW+100	1,5 LW+100
Operator depth in mm	252	252	252	252	252
Operator height in mm	100	100	100	100	100
Use in escape routes and emergency exits	-	-	-		
Force limitation in accordance with EN 16005/DIN 18650	●	●	●	●	●
Operating noise	<47 dB(A)	<47 dB(A)	<47 dB(A)	<47 dB(A)	<47 dB(A)
Settings					
Opening speed (adjustable in increments)	10 – 70 cm/s	10 – 90 cm/s	10 – 70 cm/s	ca. 20 – 70 cm/s	ca. 20 – 90 cm/s
Closing speed (adjustable in increments)	10 – 70 cm/s	10 – 90 cm/s	10 – 70 cm/s	10 – 70 cm/s	10 – 90 cm/s
Low speed OPEN	0 – 9 cm/s	0 – 9 cm/s	–	0 – 9 cm/s	0 – 9 cm/s
Low speed CLOSE	3 – 9 cm/s	3 – 9 cm/s	–	3 – 9 cm/s	3 – 9 cm/s
Hold-open time, night/bank hold-open time	0 – 180 s	0 – 180 s	0,5 – 30 s	0 – 180 s	0 – 180 s
Night/bank opening delay	0 – 10 s	0 – 10 s	–	0 – 10 s	0 – 10 s
Partial opening	25 – 400 cm	25 – 400 cm	25 – 400 cm	25 – 400 cm	25 – 400 cm
Low-speed travel OPEN/CLOSE	0 – 30 cm	0 – 30 cm	0 – 30 cm	0 – 30 cm	0 – 30 cm
Power supply					
Supply voltage	230 V, 50/60 Hz	230 V, 50/60 Hz	230 V, 50/60 Hz	230 V, 50/60 Hz	230 V, 50/60 Hz
Power consumption	130 W	180 W	130 W	130 W	180 W
On-site line fuse	10 A	10 A	10 A	10 A	10 A
Degree of protection	IP 20	IP 20	IP 20	IP 20	IP 20
Power supply for peripheral equipment under network conditions	24 V DC/2A	24 V DC/2A	27 V DC/1A	24 V DC/2A	24 V DC/2A
Power supply for peripheral equipment in the event of a power failure (battery operation)	Optional 21–27 V DC/2A	Optional 21–27 V DC/2A	Optional 21–27 V DC/1A	21–27 V DC/2A	21–27 V DC/2A
Temperature range	-20 – + 60 °C	-20 – + 60 °C	-20 – + 60 °C	-20 – + 60 °C	-20 – + 60 °C
Permissible air humidity (relative) (non-condensing)	max. 93 %	max. 93 %	max. 93 %	max. 93 %	max. 93 %
Standardisation and testing					
Compliant with the Low Voltage Directive and the EMC Directive	●	●	●	●	●
Monitoring of secondary closing edges verified to fulfil German standard DIN 18650 and EN 16005.	●	●	●	●	●
Manufactured to ISO 9001	●	●	●	●	●
Environmental product declaration according to ISO 14025; declaration holder: Institut Bauen und Umwelt e.V.	●	●	●	●	●

Header profiles

Profiles for 100 mm and 150 mm installation heights, for corridor or wall installation, enable the system to be adapted to all conceivable areas of application. The basic mechanical system, with a low number of components, is the same for both installation heights.

- 01 Aluminium girder
- 02 Mounting profile
- 03 Header profile
- 04 Internal casing for 100 mm drive height
- 05 Sensor casing for 100 mm drive height
- 06 Internal casing for 150 mm drive height
- 07 Cover bracket

Profiles for corridor installation:
100 mm

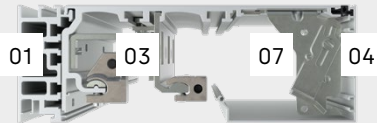

Profiles for wall installation:
100 mm

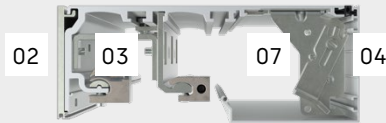

Profiles for wall installation:
100 mm with sensor casing



Profiles for corridor installation:
150 mm

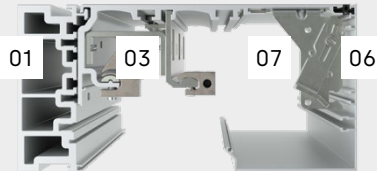

Profiles for wall installation:
150 mm

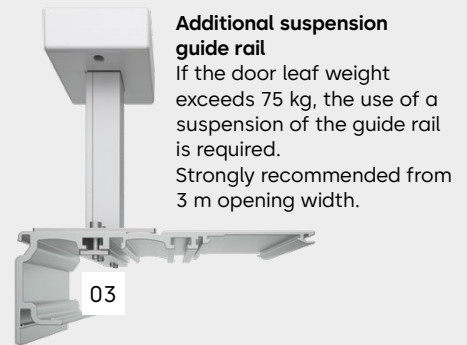
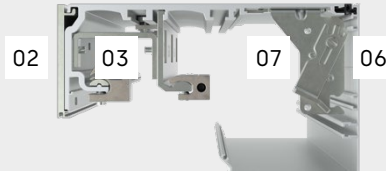

Schematic illustration of door cross-section (operator and sliding panel)

Schematic illustration of door cross-section: wall mounted, drive height 100 mm

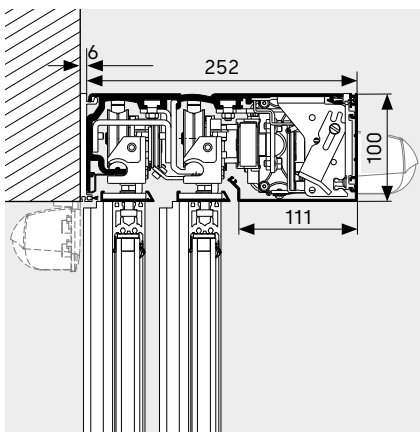

Schematic illustration of door cross-section: wall mounted, sensor casing, drive height 100 mm

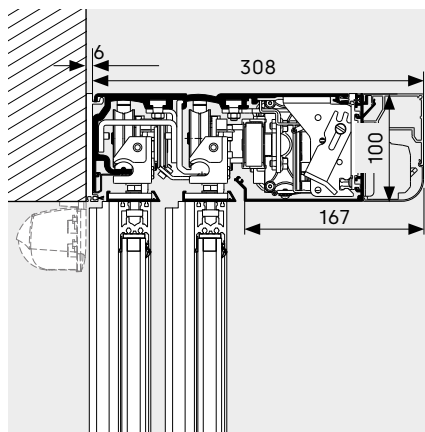

Schematic illustration of door cross-section: wall mounted, drive height 150 mm

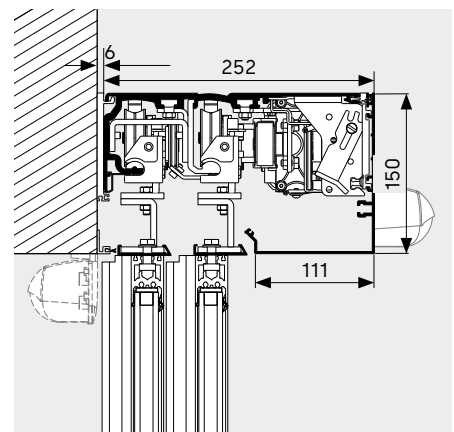

Connections with CAN-bus technology

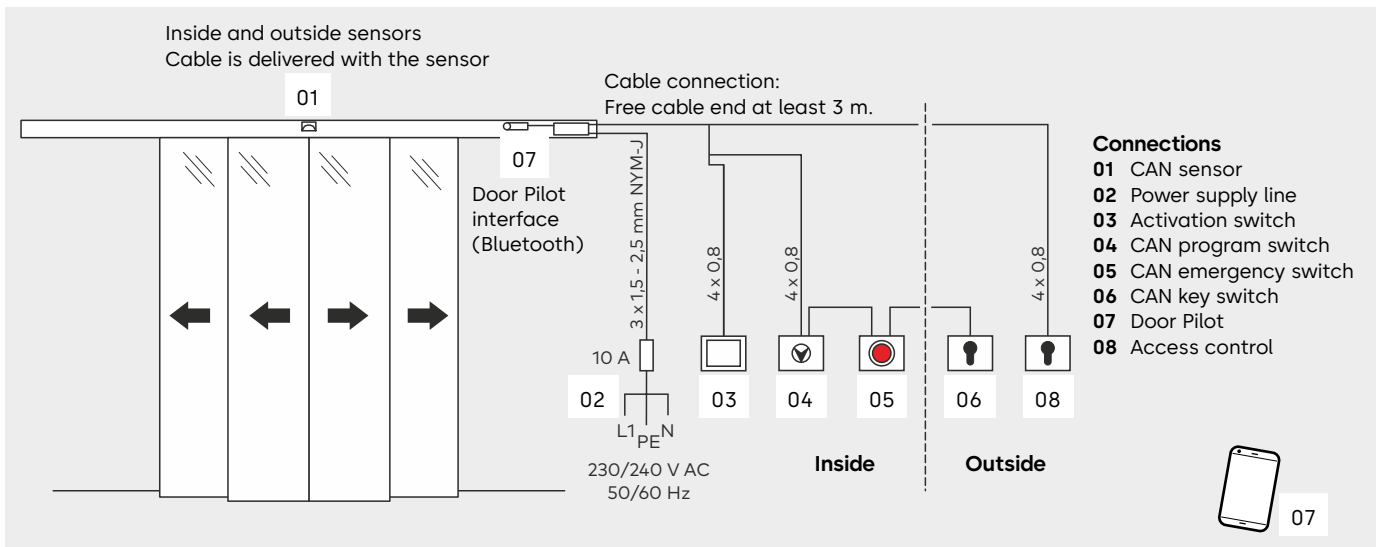

Conventional technology connections

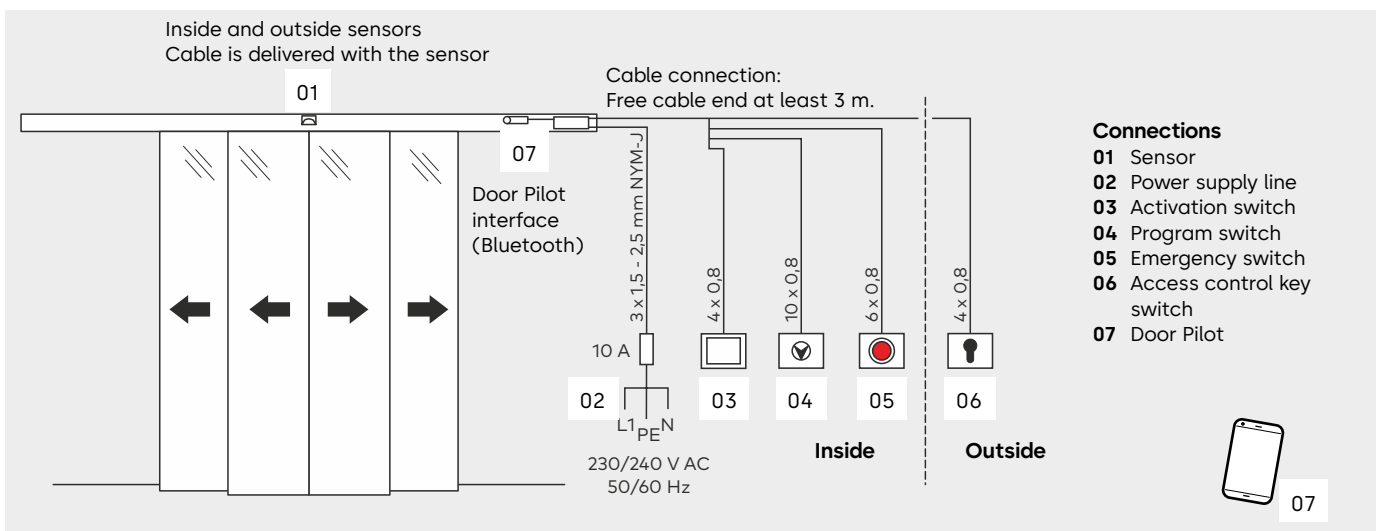

Locking devices

dormakaba offers a range of locking device variants for the ES PROLINE to prevent unauthorised access to buildings by opening the sliding door.

Electro-mechanical belt locking device

The self-adjusting locking device is attached directly to the drive unit of the operator. The standard lock status signal contacts increase the operational safety of the door.

The locking device function is configured ex works to be bistable; this means that the locking device status is maintained in the event of a power failure. Versions with other functions (monostable with Failsafe: opens the locking device in the event of a power failure and Failsecure: closes the locking device in the event of a power failure) are also available.

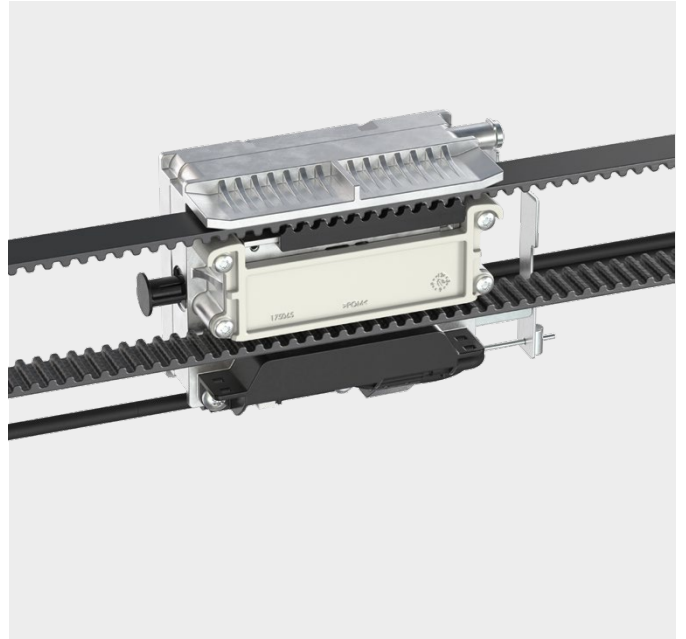

Magnetic locking device (FIA) for escape route and emergency exit doors

When using the magnetic locking device and the ES PROLINE control variant, you can lock an escape route sliding door in all automatic program switch positions, even when persons are present in the building. The locking device system has been type-approved by the German Technical Inspectorate and does not require approval in each individual case.

This variant is suitable for all properties that are used 24 hours a day, such as self-service areas in banks, hotels, hospitals, schools, etc. Any person can leave the building safely in case of an emergency and the door provides protection against uninvited guests.

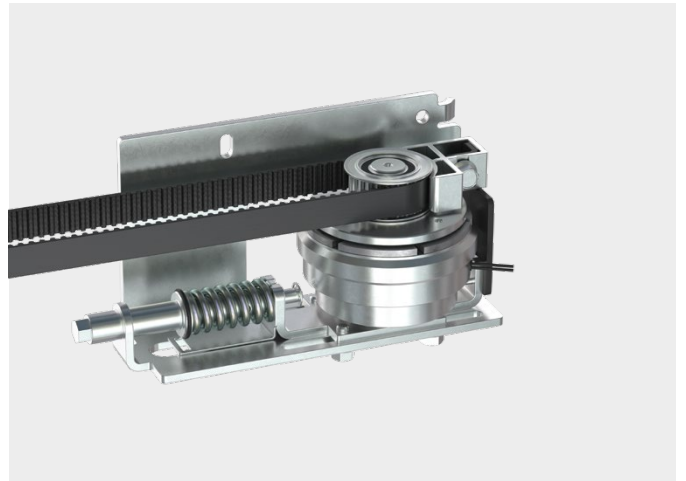

Electromotive hook locking device

This particularly robust multipoint locking device provides a very high level of break-in protection for standard sliding doors and doors of resistance classes RC2/RC3 (doors with increased anti-intruder protection are equipped with these locking devices as standard). Five solid swing bolts are extended by a motor to lock the door. Mechanical unlocking devices for opening doors manually are optionally available.

The following applies to all types of mechanical locks for doors used in escape routes and emergency exits: locking is only permitted if there are no persons in the building.

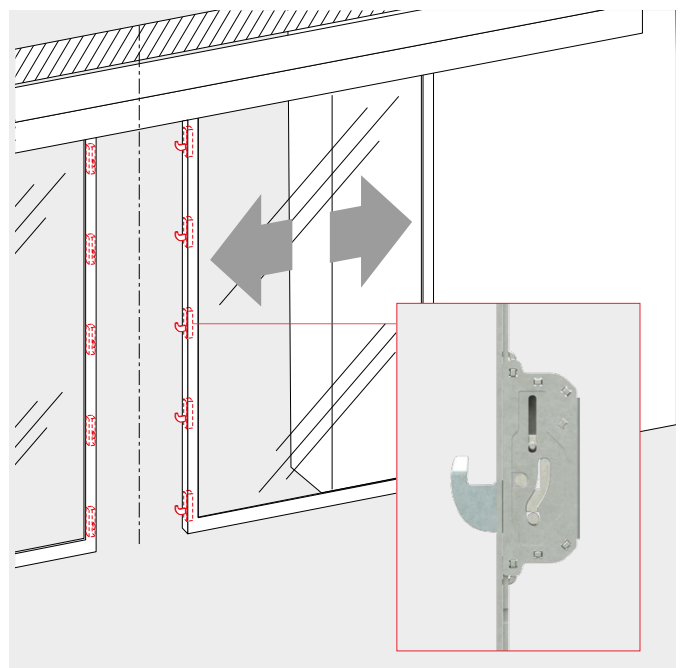

Casing variants



Standard casing

The standard casing for ES PROLINE operators is available in two different versions (height 100 mm, 150 mm). A cover bracket is supplied as standard and allows the casing to be opened in three different positions.

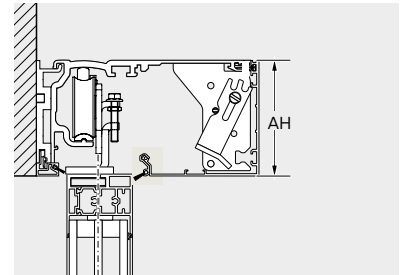

Sensor casing

Sensor casing is the right solution when it comes to premium design requirements. It creates a sleek look for doors with 100 mm drive heights. Activation and safety sensors are integrated into the drive system. There is no need for disruptive additional units and visible components. The sensor casing is approved for doors with a clear passage height of max. 3000 mm.

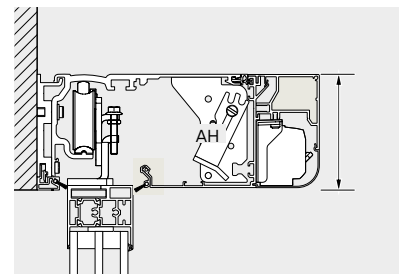

Integrated casing

Integrated casing allows the ES PROLINE operator to be elegantly concealed in suspended ceilings. The operator cover can be detached from below to allow easy access to all the components when carrying out maintenance tasks. Special accessories sets make it possible to integrate the safety sensors in the cover so that the entire height of the passage area can be used.

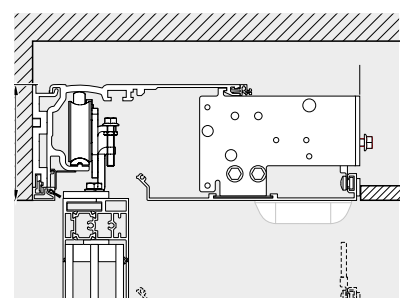

Additional track rail suspension

Optionally available, for instance, for particularly heavy skylight weights.



Master controller functions and optional expansion module functions



A wide variety of functions can already be tapped into just using the master controller for the ES PROLINE sliding door operators. The optional expansion modules can be used to implement various special functions and connect conventional accessories that are not based on CAN-bus technology.

Master controller	PRO	PRO FST	PRO EASY
Pharmacy function/pharmacy door opening The door can be locked in a partially open position apart from when the program switch is in the "Off" position. This allows a pharmacy to dispense goods securely outside business hours, for example.	●	●	–
Door status signal contacts This function issues door statuses. E.g. Door open/closed/locked, System OK, Current door position.	●	●	●
Panic closing This function closes the door immediately and switches off passage security and force limitation. This function is only permissible in certain countries (observe regional regulations).	●	–	–
Door bell contact For connecting an on-site door bell or an audible indicator.	●	●	–
Airlock function The doors can be switched to function as a personal interlock (not for escape route systems).	●	–	–
Synchronous operation For instance, two doors opening on one side can be switched to act as one large, double-leaf door. This allows particularly wide opening distances or high door leaf weights to be achieved.	●	●	–
Safety deactivation The door can be opened or closed by pressing a button.	●	●	–
Night/bank function Allows the connection of access controls, key switches etc. with the program switch in the "Off" position. The door unlocks – opens – closes – locks.	●	●	●
Emergency open	–	●	–
Emergency stop	●	–	–
Configurable partial opening distance	●	●	●
Slide and Go An opening signal can be triggered by gently pushing the door leaf.	●	●	–
Unlock/lock in case of malfunction In case of system malfunction, a door can be deliberately triggered to close and lock or unlock and open.	●	●	–
Fire service function Used to deliberately open and close a door via a separate signal input.	●	●	–

● Function can be implemented via the four programmable inputs and outputs. – Function is not implementable

Expansion modules	PRO	PRO FST	PRO EASY
4 I/O Expansion module The 4 I/O module is capable of four inputs and four outputs. The master controller functions can be implemented if the master controller connections have already been assigned. Only one module can be used at a time.	○	○	–
Safety and activation (SiAK) expansion module The safety and activation (SiAK) expansion module is used to connect conventional accessories, such as sensors and radar detectors. Safety sensors can be connected either for the main closing edge (MCE) or the secondary closing edge (SCE). Two modules are required in order to combine these safety functions (MCE/SCE).	○	○	–
Program switch (MS) expansion module Used to connect a conventional program switch (mode switch/MS) that is not based on CAN-bus technology. Only one module can be used at a time.	○	○	–

○ optional – not extendable

Door Pilot App



The dormakaba Door Pilot app allows automatic doors to be easily controlled from a smartphone. Operators from the ES PROLINE series can be equipped with the Door Pilot interface as an option. The app is available in iOS and Android versions and can be obtained from the respective app store.

Program switch functions

Use 6 different functions:

automatic	Opens from the inside and outside – perfect for normal opening hours.
Partial opening	Opens from the inside and outside with reduced opening width – ideal for cold winter days.
Output	Opens from the inside only – ideal for use shortly before closing time.
Permanent Open	Door is permanently open – suitable for deliveries or ventilation.
Off	Door remains closed (and perhaps locked) and can only be opened by changing the program switch position or by an externally controlled impulse.
Open-once	For easy opening in close proximity (not possible with the program switch in the "Off" position).

Door status signal contacts

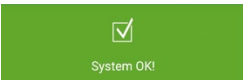
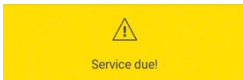
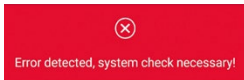
 System OK!	 Service due!	 Error detected, system check necessary!
System OK	Maintenance due	Fault detected, service due

Customer benefits

- Complement to the program switch, convenient operation from a smartphone.
- Check functions easily without needing specialist knowledge.
- No need to incorporate into existing building network.
- Direct contact function for simplified/direct access to dormakaba Service.

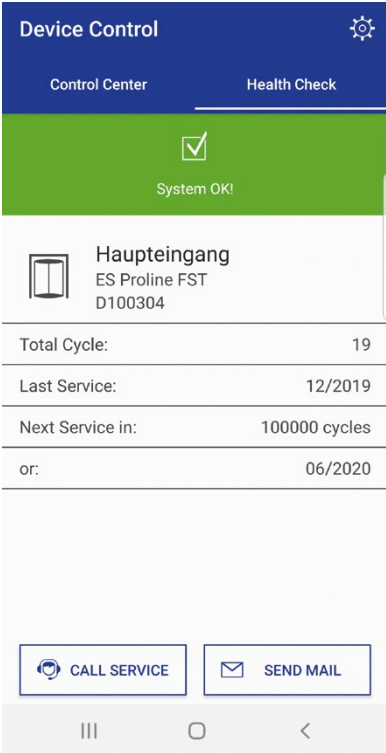
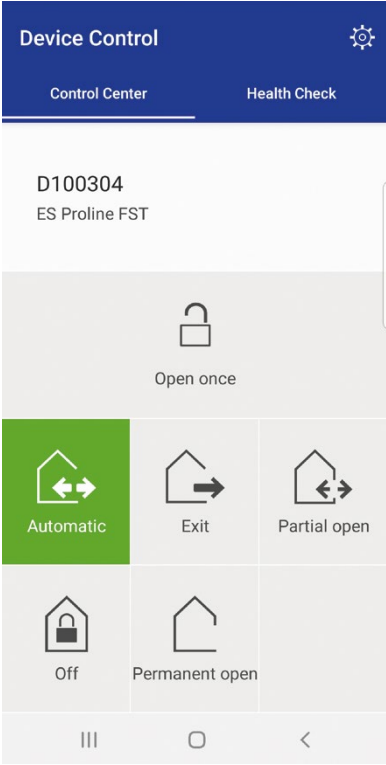

Wide range of accessories from dormakaba

Program switches

When combined with a program switch from the dormakaba accessories range, the automatic door system can satisfy all kinds of individual operating requirements and is easy to use. The program switches have been designed in various versions and for a wide range of requirements. The options range from mechanical to fully electronic versions

locked by your choice of profile cylinders, round cylinders or fully electronic coding.

- Up to 5 different functions: Off, automatic, exit only, partially open, permanent open
- Electronic program switches in System 55 design for the most discerning aesthetic demands

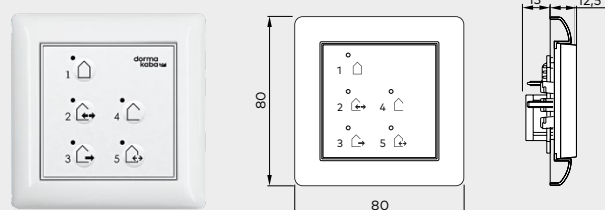

For sliding door operators without escape route and emergency exit requirements

Article no.

EPS fully electronic program switch

System 55 design, 5 positions, lockable using coding or additional TL-ST S55 key switch, membrane keypad, concealed, 80 x 80 mm

EPS, with frame	White	16556901150
EPS CAN, without frame	White	16712501150
Box for surface mounting		5226933332
EPS CAN (44 x 50 mm)		16712401150

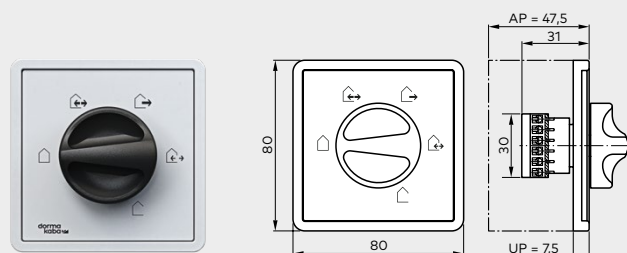

PG-S1 program switch

5 positions, aluminium, concealed, 80 x 80 x 40 mm

PG-S1	White, Gira S-Color	19135401150
Box for surface mounting		5227033332

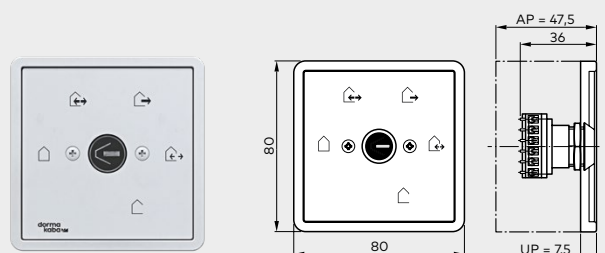

PG-S2 program switch

5 positions, lockable, aluminium, concealed, 80 x 80 x 40 mm

PG-S2	White, Gira S-Color	19135602150
Box for surface mounting		5227033332

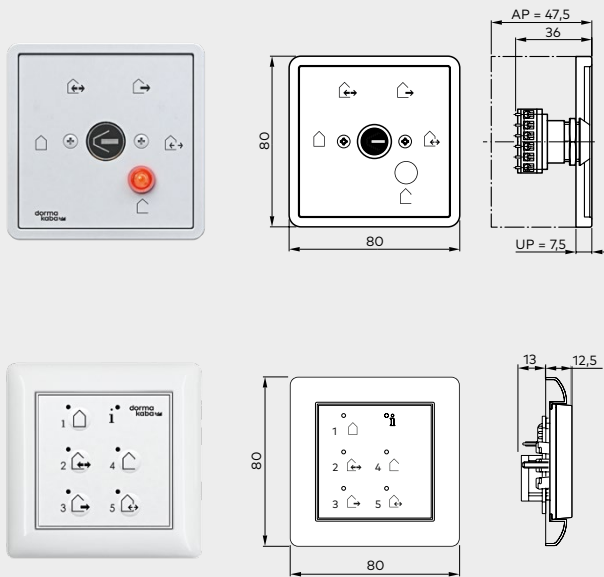

For sliding door operators in escape routes and emergency exits

Article no.

PG-FST1 program switch

5 positions, lockable, aluminium, concealed, 80 x 80 x 40 mm

PG-FST1	White, Gira S-Color	19135603150
Box for surface mounting		5080531332

EPS-FST fully electronic program switch

System 55 design, 5 positions, lockable using coding or additional TL-ST S55 key switch, membrane keypad, concealed, 80 x 80 mm

EPS-FST, with frame	White	16556801150
EPS CAN, without frame	White	16712501150
Box for surface mounting		5080531332

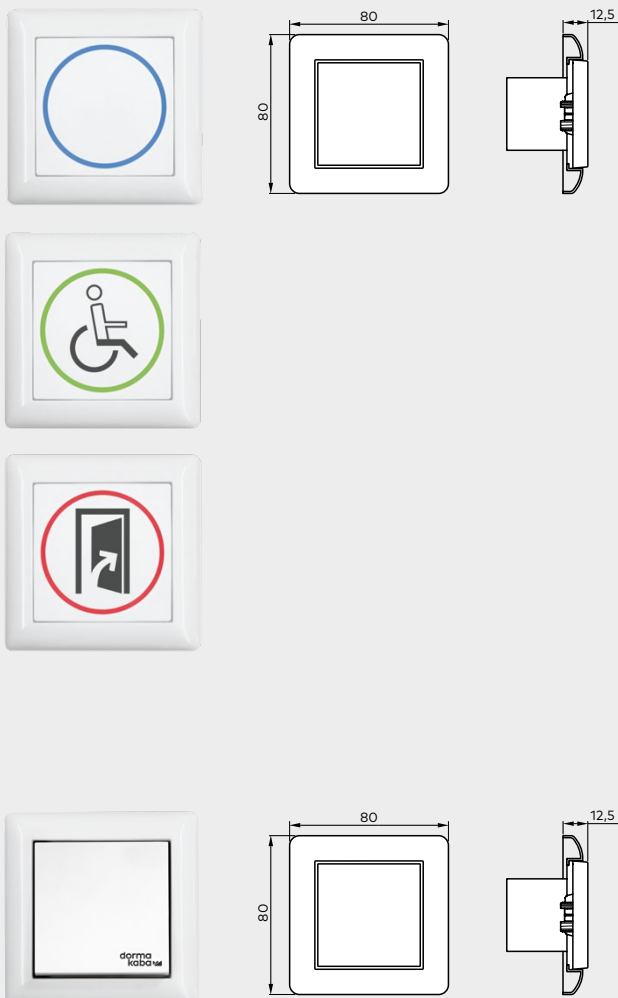

Activation switches

Article no.

CleanSwitch

contactless radar push-button, System 55, flush-mounted, detection zone adjustable 10 - 50 cm, dimensions: 80 x 80 x 40 mm, switch insert 55 x 55 mm, colour: white

CleanSwitch	neutral	16737401170
	wheelchair	16737501170
	door open	16737601170

Manual release switch

Single-pole change-over contact, single frame, concealed, System 55

Manual release switch	White	19144701170
-----------------------	-------	-------------

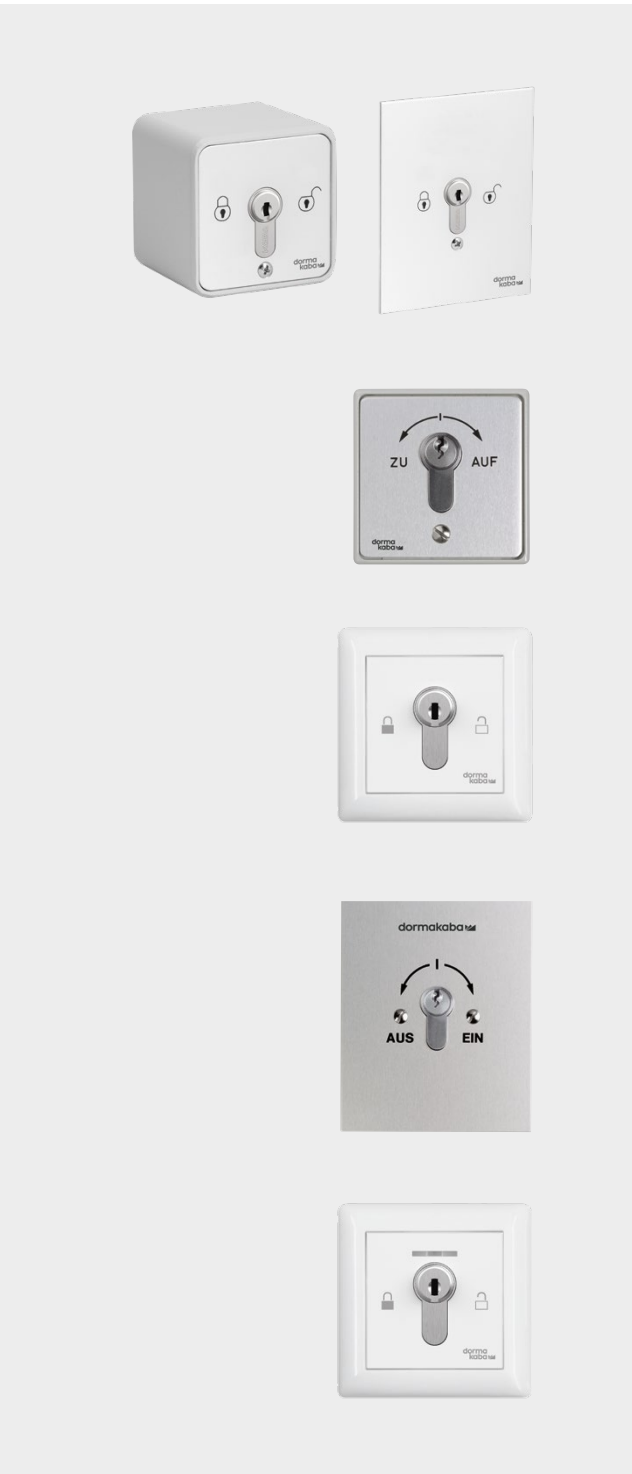

Key switch

Article no.

KT 3-1

1 NO contact with Europrofile half-cylinder in line with DIN 18252, half 30–32.5 mm, length 40.5–43.5 mm, locking cam position left (90°) (interchangeable with master-key system half-cylinder), key can only be removed in neutral position, aluminium, metal, 75 x 75 x 60 mm

KT 3-1 UP	Concealed	05054531332
KT 3-1 AP	Surface-mounted	05054631332

KT 8

Labelled "Open"/"Closed", 2 NO contacts with Europrofile half-cylinder in line with DIN 18252, half 30–32.5 mm, length 40.5–43.5 mm, locking cam position left (90°) (interchangeable with master-key system half-cylinder), key can only be removed in neutral position, aluminium, metal, 75 x 75 x 60 mm

KT 8 UP	Concealed	05054831332
KT 8 AP	Surface-mounted	05054931332

TL-ST S55

Push button with single-pole changeover contact for on-site Europrofile half-cylinder in line with DIN 18252, half 30–32.5 mm, length 40.5–43.5 mm, locking cam position left (90°), with cover for System 55, not suitable for surface-mounted boxes, without Europrofile half-cylinder, without frame.

TL-ST S55 W	White	56330710
TL-ST S55 S	Silver	56330701
TL-ST S55 A	Anthracite	56330715

KT 3-2

1 NO contact with Europrofile half-cylinder, interchangeable with master-key system half cylinder, key can only be removed in neutral position, cover panel for replacement, labelled "Open"/"Closed", aluminium, concealed: 125 x 100 mm, surface-mounted: 70 x 90 mm

KT 3-2	05054731332
--------	-------------

Key switch CAN

Switch with single-pole changeover contact, with Europrofile half-cylinder in line with DIN 18252, half 30–32.5 mm, length 40.5–43.5 mm, locking cam position left (90°) (interchangeable with master-key system half-cylinder), with cover for System 55, not suitable for surface-mounted boxes, without frame.

Schlüsseltaster CAN	16715801150
---------------------	-------------

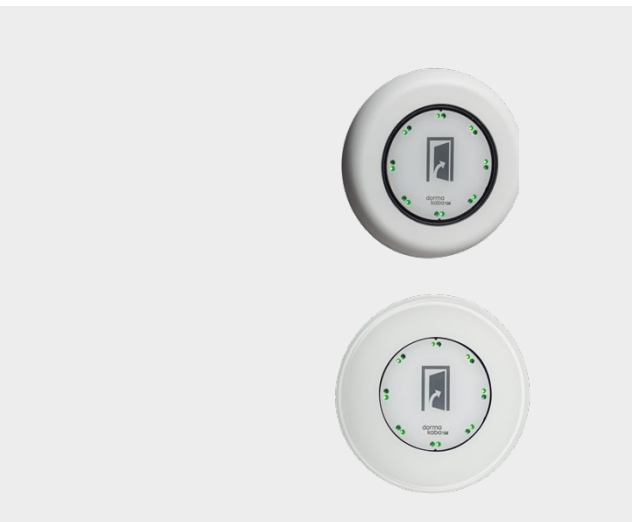

LED touch key

Article no.

LED touch key

Manual actuator with plastic frame in white, similar to RAL 9016 and traffic grey similar to RAL 7043

LED touch key	16672601170
---------------	-------------

LED hygienic touch key

Manual actuator, tempered glass encapsulated, glass button surface, hygienic version in line with EN 1672-1/2

LED touch key	16672901170
---------------	-------------

Emergency activation buttons

Article no.

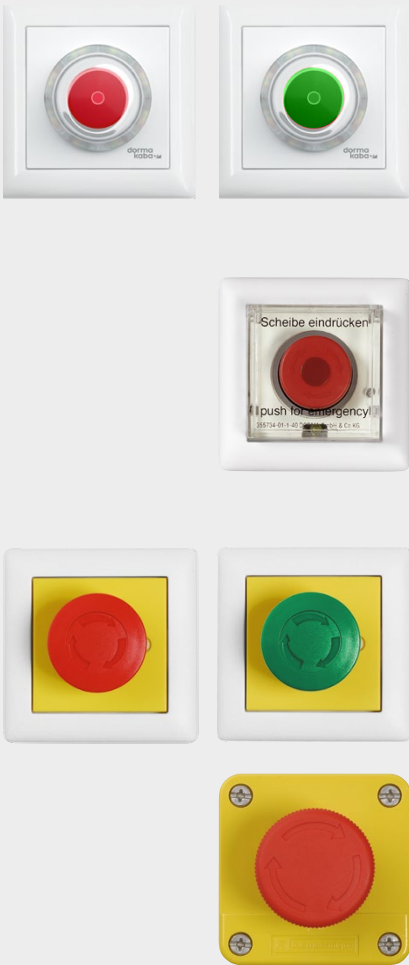

Emergency switch CAN

CAN-bus emergency activation button, red knob (emergency activation button off) or green knob (emergency open), System 55, without frame.

Emergency switch CAN, red	16718501150
Emergency switch CAN, green	16718502150

TL-N S55 conventional

The area around the emergency button is brightly illuminated and has a visual display of the locking status, an acoustic and visual alarm siren, is tamper-protected under glass, one NO contact and one NC contact, concealed, 80 x 80 mm, System 55, without frame

TL-N S55	56330500
----------	----------

Conventional emergency switch

Emergency activation button (Emergency Off function with red knob and Emergency Open function with green knob) with yellow central plate

NAT 1	One NO contact and one NC contact, white frame, concealed, 80 x 80 mm, System 55	90400025
NAT 2	Emergency Open version with green knob, white frame, concealed, 80 x 80 mm, System 55	90400035
NAT 4	One NO and one NC contact, surface-mounted 68 x 68 mm Concealed	05027031332

Cover frame for buttons and switches

Article no.



Standard System 55

FR-S55 1	Single frame, white, 80.7 x 80.7	56391110
FR-S55 2	Double frame, white, 151.8 x 80.7	56391210
FR-S55 3	Triple frame, white, 223.3 x 80.7	56391310

E2 System 55 (not shown)

FR-E2W 1	Single frame, E2 55, white, 80.8 x 80.8	56392110
FR-E2W 2	Double frame, E2 55, white, 151.9 x 80.8	56392210
FR-E2W 3	Triple frame, E2 55, white, 223.4 x 80.8	56392310
FR-E2S 1	Single frame, E2 55, silver, 80.8 x 80.8	56392101
FR-E2S 2	Double frame, E2 55, silver, 151.9 x 80.8	56392201
FR-E2S 3	Triple frame, E2 55, silver, 223.4 x 80.8	56392301
FR-E2A 1	Single frame, E2 55, anthracite, 80.8 x 80.8	56392115
FR-E2A 2	Double frame, E2 55, anthracite, 151.9 x 80.8	56392215
FR-E2A 3	Triple frame, E2 55, anthracite, 223.4 x 80.8	56392315

Active infrared sensor and combined sensors

Article no.



Combined sensor IXIO-DT1

Combined sensor featuring radar detector with direction recognition and safety curtain for non-escape route systems, width 270 mm

IXIO-DT1	Black	86800001
	Silver	86800002
	White	86800003

Combined sensor IXIO-DT3

Combined sensor featuring self-monitored radar detector with direction recognition and safety curtain for escape route systems, width 270 mm

IXIO-DT3	Black	86800004
	Silver	86800005
	White	86800006

Safety curtain IXIO-ST

Safety curtain (tested) IXIO-ST for monitoring closing edges, width 270 mm

IXIO-ST	Black	86800010
	Silver	86800011
	White	86800012

Combined sensor IXIO-D CAN

Combined sensor featuring radar detector with direction recognition and safety curtain for escape route systems and non-escape route systems (CAN-bus technology), width 270 mm

IXIO-D CAN	Black	86800053
	Silver	86800057
	White	86800056

Safety curtain IXIO-S CAN

Safety curtain (tested) IXIO-S CAN for monitoring closing edges (CAN-bus technology), width 209 mm

IXIO-S CAN	Black	86800055
	Silver	86800059
	White	86800058

Integrated combined sensor IXIO-D CAN

Combined sensor (without cover) featuring self-monitored radar detector with direction recognition and safety curtain for escape route and non-escape route systems for integration into the sensor casing.

Integrated IXIO-D CAN	86800050
-----------------------	----------

Integrated safety curtain IXIO-S CAN

IXIO-S CAN safety curtain (tested, without cover) for monitoring closing edges (CAN-bus technology), for integration into the sensor casing.

Integrated IXIO-S CAN	86800052
-----------------------	----------

Accessories for active infrared sensor and combined sensors

Article no.



Ceiling installation set

Ceiling installation system for IXIO-DT, IXIO-S, IXIO-D-CAN and IXIO-S-CAN, housing width 270 mm or 209 mm

Ceiling installation set	Black	86800019
	White	86800020

Rain protection cover

Rain protection cover for IXIO-DT, IXIO-ST, IXIO-D-CAN and IXIO-S-CAN, housing width 209 mm or 270 mm

Rain protection cover	Black	86800021
-----------------------	-------	----------

Fixing bracket

Fixing bracket for IXIO sensor

Fixing bracket for housing width 270 mm	Black	86800016
---	-------	----------

Fixing bracket for housing width 209 mm	Black	86800018
---	-------	----------

Our Sustainability Commitment

We are committed to foster a sustainable development along our entire value chain in line with our economic, environmental and social responsibilities toward current and future generations. Sustainability at product level is an important, future-oriented approach in the field of construction. In order to give quantified disclosures of a product's environmental impact through its entire life cycle, dormakaba provides Environmental Product Declarations (EPD), based on holistic life cycle assessments.

www.dormakaba.com/sustainability



Our offering

Access Automation Solutions

Entrance Automation
Entrance Security



Access Control Solutions

Electronic Access & Data
Escape and Rescue Systems
Lodging Systems



Access Hardware Solutions

Door Closers
Architectural Hardware
Mechanical Key Systems



Services

Technical Support
Installation and commissioning
Maintenance and Repair



WN 05522051532, EN, 01/2026
Subject to technical modifications.



dormakaba.com

dormakaba
International Holding AG
Hofwissenstrasse 24
CH-8153 Rümlang
T +41 44 818 90 11
info@dormakaba.com
dormakaba.com