

Kentaur

Turnstiles

Full-height gates

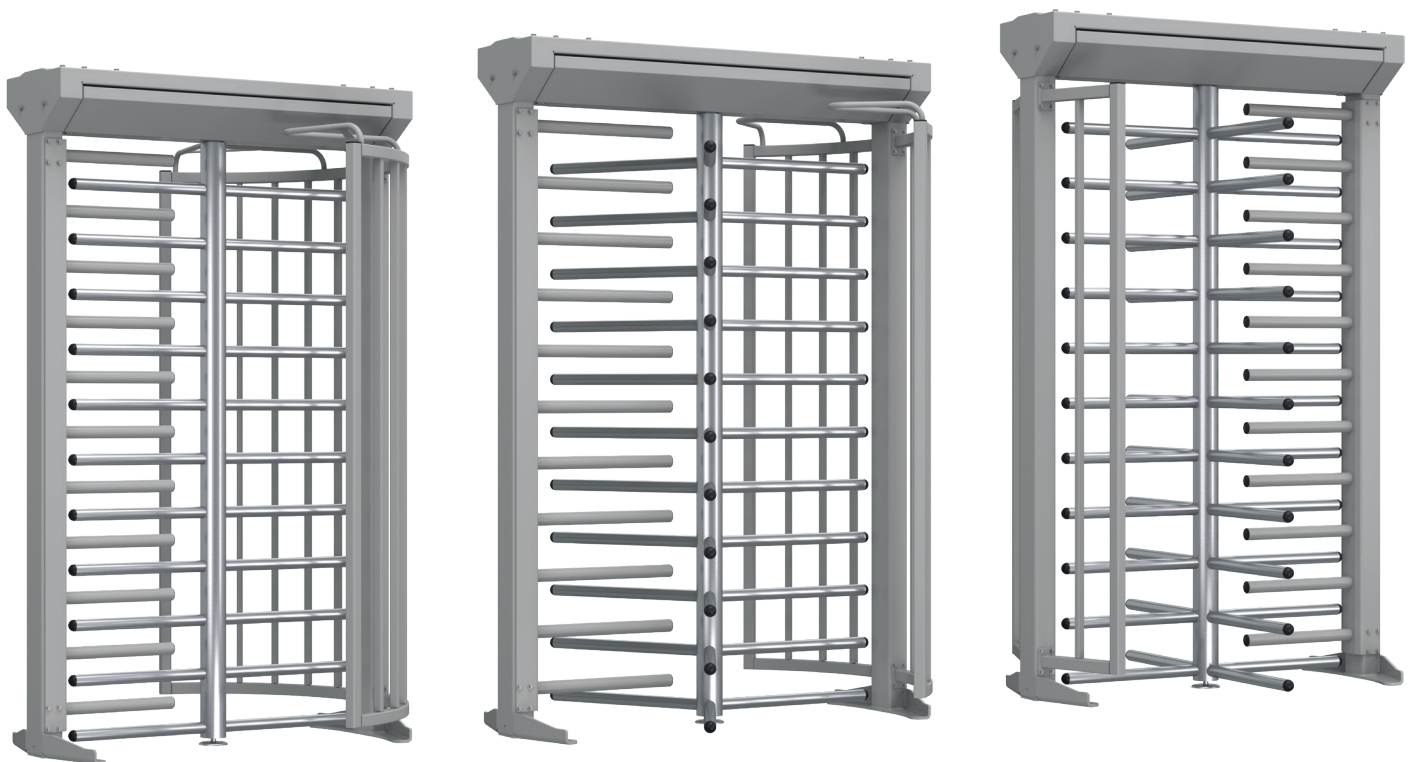

Secure Kentaur Turnstiles

Versatile
Durable
Modular

The robust Kentaur turnstiles and full-height gates are especially suitable for securing the perimeter of buildings and property. Versatile versions enable individual combinations of multiple units to be put together. The end point locking system developed by dormakaba prevents people from being trapped in the gates.

Versatility

The Kentaur product series offers a modular design. Two, three and four-winged units with straight or U-shaped bars can be combined with each other. The same applies for units with bicycle doors, integrated doors, or of resistance class RC2. The roofs fit with any of the single, multiple or space-saving double units.

Minimal power consumption

The quiet low-energy drive consumes very little energy and adapts to the speed of the person entering.

Safe passage

The end point locking implemented in Kentaur turnstiles prevents people from becoming trapped or jammed. After release the turnstile may be stopped at any time and rotated backwards as long as it has not yet completed half of its rotation. Once the turnstile has completed half of its rotary motion, the unit can only be exited in the released direction.



Advantages of Kentaur Turnstiles

The right combination of security, user comfort and personal safety.

- Users cannot become stuck thanks to end point locking
- Versions with integrated bicycle door, full-height gates for barrier-free access or as a goods entrance or in resistance class RC2
- Space-saving double units
- Modular combination of bars, roofs, guiding and barrier elements
- Lasting quality for indoor and outdoor installation
- Stainless steel version of the system possible
- Rotating speed adapts to the pedestrian
- Low-energy drive
- Low power consumption
- Behaviour in the event of a power failure can be freely determined
- Can be used in regions with harsh environmental conditions
- IP55 protection possible
- Integrated, parameterisable random generator
- Optional secondary identification for additional security
- Sensor-monitored pass-through signal possible
- Difference counter possible in both directions
- Spacing between shearing edges eliminates risk of injury
- Suitable for max. snow load of 4.28 kN/m² = snow load zone 3 according to DIN EN 1991-1-3
- Suitable for max. wind speed of 108 km/h = wind load zone 4 according to DIN EN 1991-1-4
- All distances are dimensioned in accordance with DIN EN 17352 so that there is no risk of injury



Kentaur full-height gates in a matching design offer a fitting addition for disabled access.

The ideal solution for any access point



01 Turnstile with integrated full-height gate as entrance to an underground car park



02 Controlled access to a stadium



03 Turnstile offering additional protection for a restricted area



04 Full-height gate as goods entrance

For reliable security at:

- Manufacturing plants
- Company sites
- Airports and ports
- Power plants
- Car parks
- Bicycle stands
- Correctional facilities
- Military installations
- Educational centres
- Stadiums
- Amusement parks

Throughput rate = up to 20 per minute

Security level = ●●●●○

Comfort = ●●●●○

Staff supervision = no





Kentaur turnstiles

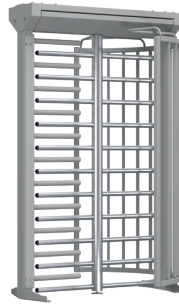

Kentaur FTS-E01

Standard units		
Construction	Rotating unit diameter	1110
	Portal width	1370
	Total height (without opt. roof)	2270
	Passage height	2060
	Passage width	560
	Portal and housing	Steel.
	Lockable maintenance opening	Aluminium.
	Rotating unit with tubular column, Ø 89 m	180° each with 11 bar-shaped stainless steel AISI 304 crossbars
	Barrier element	With 11 straight crossbars, made of steel.
	Passage limitation	With steel columns and climb-over protection.
Finish		Stainless steel elements glossy AISI 304, hot-dip galvanised steel elements, aluminium elements in RAL 9006 (white aluminium).
	Corrosiveness category	C3 according to DIN EN ISO 12944-2.
Function		Power-assisted motion; servo-positioning drive/electrically controlled in both directions (behaviour in event of power failure can be selected for each direction: free or blocked).
Electrical equipment		The control unit is integrated into the unit.
	Power supply	100-240 VAC - 50/60 Hz - 253 VA.
	Standby power consumption	20 VA.
Installation		In sleeve foundation, measure X = 150 mm.
	Optional roofs	Suitable for max. snow load of 4.28 kN/m ² . Suitable for max. wind speed of 108 km/h.
Protection classes		Housing IP33, components conducting supply voltage IP43.
Norm		DIN EN 17352 Further standards in the CE declaration.

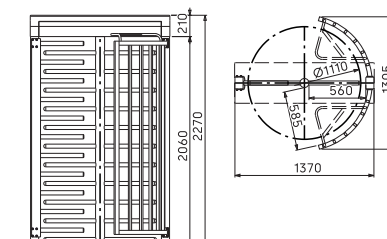

All dimensions in mm



Kentaur FTS-L04

1110

1370

2270

2060

490

Steel.

Aluminium.

90° each with 11 bar-shaped stainless steel AISI 304 crossbars

With 11 straight crossbars, made of steel.

With steel columns and climb-over protection.

Stainless steel elements glossy AISI 304, hot-dip galvanised steel elements, aluminium elements in RAL 9006 (white aluminium).

C3 according to DIN EN ISO 12944-2.

Power-assisted motion; servo-positioning drive/electrically controlled in both directions (behaviour in event of power failure can be selected for each direction: free or blocked).

The control unit is integrated into the unit.

100-240 VAC - 50/60 Hz - 253 VA.

20 VA.

In sleeve foundation, measure X = 150 mm.

Suitable for max. snow load of 4.28 kN/m².
Suitable for max. wind speed of 108 km/h.

Housing IP33, components conducting supply voltage IP43.

DIN EN 17352 Further standards in the CE declaration.

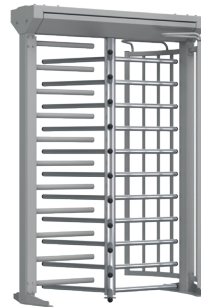
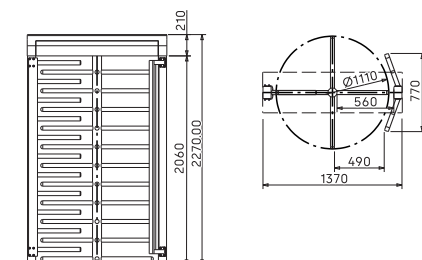

Kentaur FTS-E02

1280

1540

2270

2060

646

Steel.

Aluminium.

120° or 90° each with 11 bar-shaped stainless steel AISI 304 crossbars

With 11 straight crossbars, made of steel.

With steel columns and climb-over protection.

Stainless steel elements glossy AISI 304, hot-dip galvanised steel elements, aluminium elements in RAL 9006 (white aluminium).

C3 according to DIN EN ISO 12944-2.

Power-assisted motion; servo-positioning drive/electrically controlled in both directions (behaviour in event of power failure can be selected for each direction: free or blocked).

The control unit is integrated into the unit.

100-240 VAC - 50/60 Hz - 253 VA.

20 VA.

In sleeve foundation, measure X = 150 mm.

Suitable for max. snow load of 4.28 kN/m².
Suitable for max. wind speed of 108 km/h.

Housing IP33, components conducting supply voltage IP43.

DIN EN 17352 Further standards in the CE declaration.

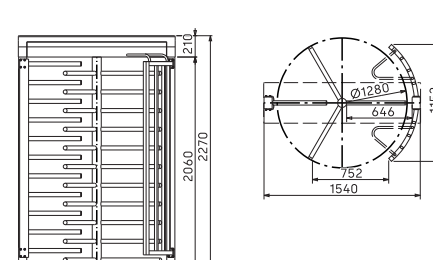

Kentaur turnstiles

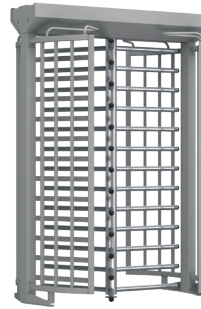

Kentaur FTS-E04

Standard units		
Construction	Rotating unit diameter	1280
	Portal width	1540
	Total height (without opt. roof)	2270
	Passage height	2060
	Passage width	646
	Portal and housing	Steel.
	Lockable maintenance opening	AISI 304 stainless steel.
	Rotating unit with tubular column, Ø 89 m	120° each with 13 bar-shaped stainless steel AISI 304 crossbars.
	Barrier element	With 12 curved steel bars.
	Passage limitation	With steel columns, climb-over protection and saw-through protection.
Finish	Additional function	The unit complies with resistance class RC2 according to DIN V ENV 1627.
	Corrosiveness category	Stainless steel elements glossy AISI 304, hot-dip galvanised steel elements, aluminium elements in RAL 9006 (white aluminium). C3 according to DIN EN ISO 12944-2.
Function	Power-assisted motion; servo-positioning drive/electrically controlled in both directions (behaviour in event of power failure can be selected for each direction: free or blocked).	
Electrical equipment	The control unit is integrated into the unit.	
	Power supply	100-240 VAC - 50/60 Hz - 253 VA.
	Standby power consumption	20 VA.
Installation	In sleeve foundation, measure X = 150 mm.	
	Optional roofs	-
Protection classes	Housing IP33, components conducting supply voltage IP43.	
Norm	DIN EN 17352 Further standards in the CE declaration.	

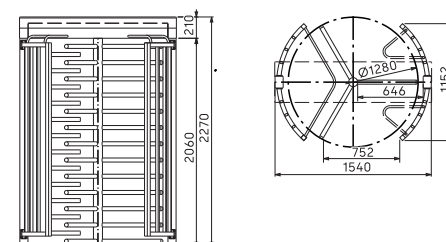

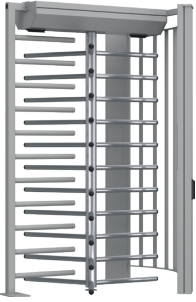

Kentaur FTS-E05

1280

1500

2270

2060

646

Steel.

Aluminium.

120° or 90° each with 11 bar-shaped hot-dip galvanised steel crossbars.

With 11 straight crossbars, made of steel.

With steel columns and climb-over protection.

-

Stainless steel elements glossy AISI 304, hot-dip galvanised steel elements, aluminium elements in RAL 9006 (white aluminium).

C3 according to DIN EN ISO 12944-2.

Power-assisted motion; servo-positioning drive/electrically controlled in both directions (behaviour in event of power failure can be selected for each direction: free or blocked).

The control unit is integrated into the unit.

100-240 VAC - 50/60 Hz - 253 VA.

20 VA.

On finished floor level FFL.

-

Housing IP33, components conducting supply voltage IP43.

DIN EN 17352 Further standards in the CE declaration.

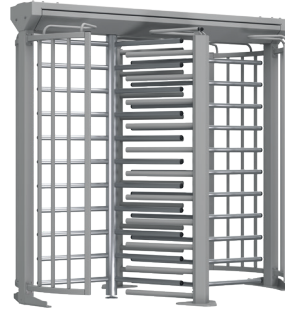
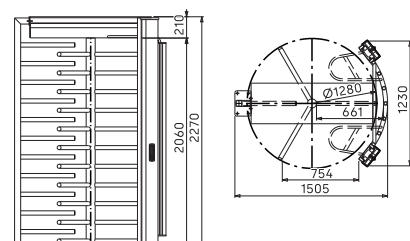

Kentaur FTS-E06

1280

2340

2270

2060

646

Steel.

Aluminium.

120° each with 11 bar-shaped stainless steel AISI 304 crossbars.

In middle part with 21 straight crossbars made of steel.

With steel columns and climb-over protection.

Minimal space requirement due to interlocking rotating units.

Stainless steel elements glossy AISI 304, steel, hot-dip galvanised steel elements, aluminium elements in RAL 9006 (white aluminium).

C3 according to DIN EN ISO 12944-2.

Power-assisted motion; servo-positioning drive/electrically controlled in both directions (behaviour in event of power failure can be selected for each direction: free or blocked).

The control unit is integrated into the unit.

100-240 VAC - 50/60 Hz - 506 VA.

40 VA.

In sleeve foundation, measure X = 150 mm.

Suitable for max. snow load of 4.28 kN/m².
Suitable for max. wind speed of 108 km/h.

Housing IP33, components conducting supply voltage IP43.

DIN EN 17352 Further standards in the CE declaration.

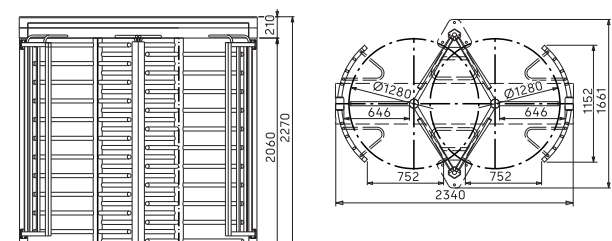

Kentaur turnstiles



Standard units

Construction	Rotating unit diameter	1280
	Portal width	2440
	Total height (without opt. roof)	2270
	Passage height	2060
	Passage width	646
	Portal and housing	Steel.
	Lockable maintenance opening	Aluminium.
	Rotating unit with tubular column, Ø 89 mm	120° each with 11 bar-shaped stainless steel AISI 304 crossbars.
	Barrier element	With 11 straight crossbars or 7 bow-shaped, made of steel, with climb-over protection.
	Passage limitation	Half-height made of curved tubular AISI 304 stainless steel with plate panels.
	Additional function	Automatic bicycle door.
Finish		Stainless steel elements glossy AISI 304, hot-dip galvanised steel elements, aluminium elements in RAL 9006 (white aluminium).
	Corrosiveness category	C3 according to DIN EN ISO 12944-2.
Function		Power-assisted motion; servo-positioning drive/electrically controlled in both directions (behaviour in event of power failure can be selected for each direction: free or blocked). Automatic bicycle door with two induction loops and loop detector, electronically controlled in two directions.
Electrical equipment		Control system integrated in the unit.
	Power supply	100-240 VAC, 50/60 Hz, 506 VA.
	Standby power consumption	20 VA.
Installation		In sleeve foundation, measure X = 150 mm.
	Optional roofs	Suitable for max. snow load of 4.28 kN/m ² . Suitable for max. wind speed of 108 km/h.
Protection classes		Housing IP33, components conducting supply voltage IP43.
Special feature		-
Norm		DIN EN 17352 Further standards in the CE declaration.

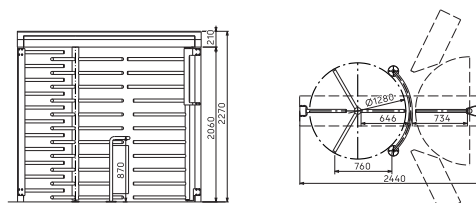

All dimensions in mm



Kentaur FTS-M05

1110

1940

2270

2060

560

Steel.

Aluminium.

180° each with 11 bar-shaped stainless steel AISI 304 crossbars.

Integrated swing door with 10 straight crossbars and continuous frame.

With steel columns and climb-over protection.

Integrated door that can be opened when required, disabled access and suitable for emergency escape.

Stainless steel elements glossy AISI 304, hot-dip galvanised steel elements, aluminium elements in RAL 9006 (white aluminium).

C3 according to DIN EN ISO 12944-2.

Power-assisted motion; servo-positioning drive/electrically controlled in both directions (behaviour in event of power failure can be selected for each direction: free or blocked). SafeRoute-Emergency exit function: The rotating unit turns automatically 90° in passage direction when the door is opened.

Control system integrated in the unit.

100-240 VAC - 50/60 Hz - 335 VA.

20 VA.

In sleeve foundation, measure X = 150 mm.

Suitable for max. snow load of 4.28 kN/m². Suitable for max. wind speed of 108 km/h.

Housing IP33, components conducting supply voltage IP43. IP44 escape route terminal.

-

DIN EN 17352 Further standards in the CE declaration.

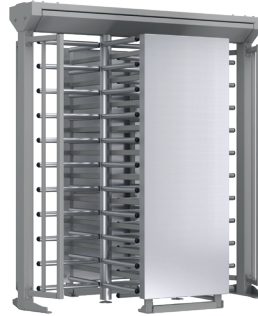
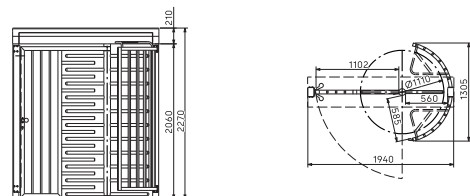

Kentaur FTS-L01

1110

2050

2270

2060

490

Steel.

Aluminium.

90° each with 11 bar-shaped stainless steel AISI 304 crossbars.

Steel in the mid-section, encased in stainless steel, semi-gloss smooth finish on the front panels.

With steel columns.

Low space requirement due to interlocking rotating units.

Stainless steel elements glossy AISI 304, hot-dip galvanised steel elements, aluminium elements in RAL 9006 (white aluminium).

C3 according to DIN EN ISO 12944-2.

Power-assisted motion; servo-positioning drive/electrically controlled in both directions (behaviour in event of power failure can be selected for each direction: free or blocked). SafeRoute-Emergency exit function: The rotating unit turns automatically 90° in passage direction when the door is opened.

The control unit is integrated into the unit.

100-240 VAC, 50/60 Hz, 506 VA.

40 VA.

On finished floor level FFL.

Suitable for max. snow load of 4.28 kN/m². Suitable for max. wind speed of 108 km/h.

Housing IP33, components conducting supply voltage IP43.

Ideal for stadiums.

DIN EN 17352 Further standards in the CE declaration.

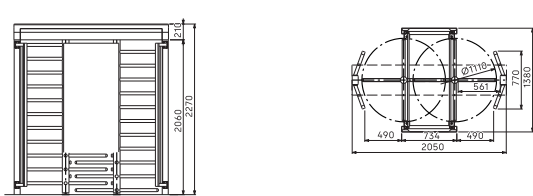

Kentaur full-height swing door



Standard unit

Application	
Construction	Portal width
	Total height (without opt. roof)
	Passage height
	Passage width
	Portal and housing
	Lockable maintenance opening
	Hinge door with tubular column, Ø 60 mm
Finish	
Corrosiveness category	
Function	
Electrical equipment	
Power supply	
Standby power consumption	
Installation	
Optional roofs	
Protection classes	
Norm	

Kentaur FGE-M01

Barrier-free passage of persons and material handling.

1370

2270

2060

1080

Steel.

Aluminium.

With 11 bar-shaped glossy stainless steel AISI 304 crossbars.

Stainless steel elements glossy AISI 304,
Hot-dip galvanised steel elements,
aluminium elements in RAL 9006 (white aluminium).

C3 according to DIN EN ISO 12944-2.

Power-assisted motion; servo-positioning drive/electrically controlled in both directions (behaviour in event of power failure can be selected for each direction: free or blocked). SafeRoute-Emergency exit function: The rotating unit turns automatically 90° in passage direction when the door is opened.

The control unit is integrated into the unit.

100-240 VAC - 50/60 Hz - 253 VA.

20 VA.

In sleeve foundation, measure X = 150 mm.

Suitable for max. snow load of 4.28 kN/m².
Suitable for max. wind speed of 108 km/h.

Housing IP33, components conducting supply voltage IP43.

DIN EN 17352 Further standards in the CE declaration.

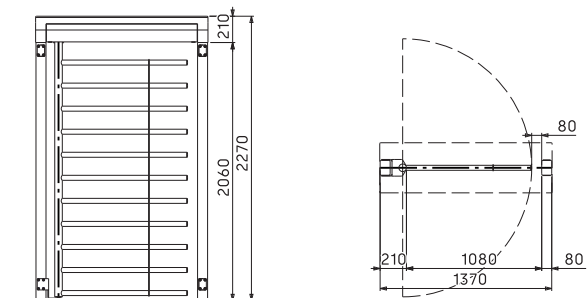



Optional roofs

	Kentaur FTS-E01	Kentaur FTS-L04	Kentaur FTS-E02	Kentaur FTS-E04	Kentaur FTS-E05	Kentaur FTS-E06	Kentaur FTS-M01	Kentaur FTS-M05	Kentaur FTS-L01	Kentaur FGE-M01
Roof D1 – depth 1500 or 2770 (total height 120)										
Width										
1650	•	•								•
1820			•							
2220								•		
2330									•	
2620						•				
2720							•			
Roof D2 and Roof D3 – depth 2820 (roof edge 200)										
Width										
1830	•	•								•
2000			•							
2400								•		
2510									•	
2800						•				
2900							•			

Roofs to prevent people climbing over and for weather protection

Roof D1

Hot-dip galvanised steel substructure, trapezoidal sheet cover in RAL 9002 grey-white (optional plastic-coated in a RAL colour). For multiple units we supply one continuous roof. For four units or more a central water outlet is required. The distance between units is 50 mm.

Roof D2

Hot-dip galvanised steel substructure, trapezoidal sheet cover in RAL 9002 grey-white (optional plastic coating in a RAL colour). With roof edge in RAL 9006 and water outlet in grey PVC. For multiple units we supply one continuous roof. The distance between units is 50 mm. The roof edge is continuous with a length of max. 6.4 m.

Roof D3

Hot-dip galvanised steel substructure, trapezoidal sheet cover in RAL 9002 grey-white (optional plastic coating in a RAL colour). With roof edge in RAL 9006 and water outlet in grey PVC. Roof underside with aluminium cladding in RAL 9010. For multiple units we supply one continuous roof. The distance between units is 50 mm. The roof edge is continuous with a length of max. 6.4 m.

All roofs are able to withstand a max. snow load of 4.28 kN/m² = snow load zone 3 according to DIN EN 1991-1-3, and max. wind speed of 108 km/h = wind load zone 4 according to DIN EN 1991-1-4.

All dimensions in mm

Roof D1 – with trapezoidal sheet cover

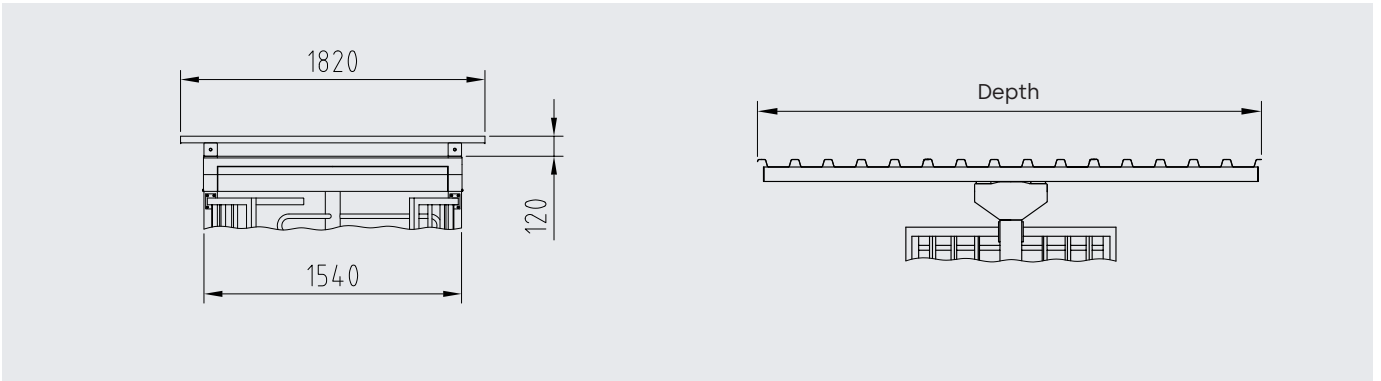

Roof D2 – with trapezoidal sheet cover, roof edge profile and water outlet

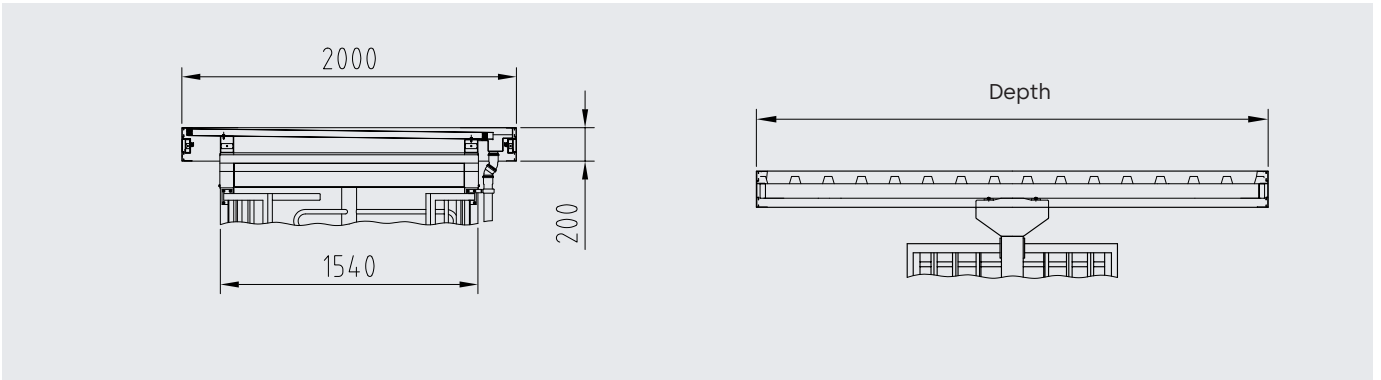

Roof D3 – with trapezoidal sheet cover, roof edge profile, panelling and water outlet

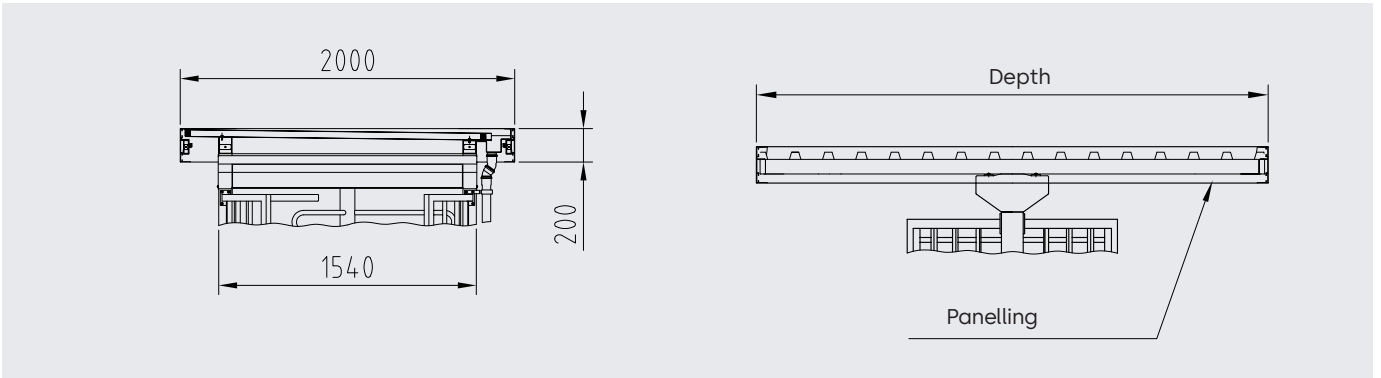

Options

(depending on unit type)

	Kentaur FTS-E01	Kentaur FTS-L04	Kentaur FTS-E02	Kentaur FTS-E04	Kentaur FTS-E05	Kentaur FTS-E06	Kentaur FTS-M01	Kentaur FTS-M05	Kentaur FTS-L01	Kentaur FGE-M01
Construction										
Housing with lockable front panel.			•			•				
Roofs D1, D2 and D3.	•	•	•			•	•	•	•	•
Curved barrier element, instead of straight crossbars.			•							
Rotating unit with curved crossbars including curved barrier element.			•				•			
Rotating unit made of AISI 316 stainless steel.	•	•	•			•	•	•	•	
Rotating unit 4-wing (90 °) made of hot-dip galvanized steel.					•					
For each direction: mechanical pivoted lever unlocking with profile half cylinder, installed in maintenance opening.	•	•	•		•	•	•	•	•	•
Finish										
Steel parts and maintenance openings also powder-coated in RAL.	•	•	•	•	•	•	•	•	•	•
Corrosiveness category C5-M.	•	•	•			•			•	
Function										
Door opener with slide bar, installed in portal housing or drive, in each case for integrated door.								•		
Two concrete blocks with embedded induction loops instead of loops supplied loose.							•			
Random generator with or without horn.	•	•	•	•	•	•	•	•	•	
Electrical equipment										
Installation preparation for dormakaba detection unit 90 04 and dormakaba compact reader 91 04.	•		•	•	•	•			•	•
Different consoles made completely of stainless steel or plastic or aluminium in colour of unit or in RAL 9006. Front panels of aluminium consoles available in plastic or stainless steel.	•	•	•	•	•	•	•	•	•	•
Button for manual single release.	•	•	•	•	•	•		•	•	
Continuous release in the entry/exit direction.	•	•	•	•	•	•	•	•	•	
Operating panels and frames or surface mount housing.	•	•	•	•	•	•	•	•	•	•
Additional circuit boards for expanding existing inputs and outputs on unit type 2.	•	•	•	•	•	•	•	•	•	•
Signal device.	•	•	•	•	•	•	•	•	•	•
Various LED lighting and twilight switch options.	•	•	•	•	•	•	•	•	•	•
Heating.	•	•	•	•	•	•	•	•	•	•
Installation										
Turnstile unit can be assembled at the factory.	•		•		•					
Mounting on finished floor level.	•	•	•	•		•	•	•	•	•
Mounting on sub floor level X = 150 mm.	•	•	•	•		•	•	•	•	•

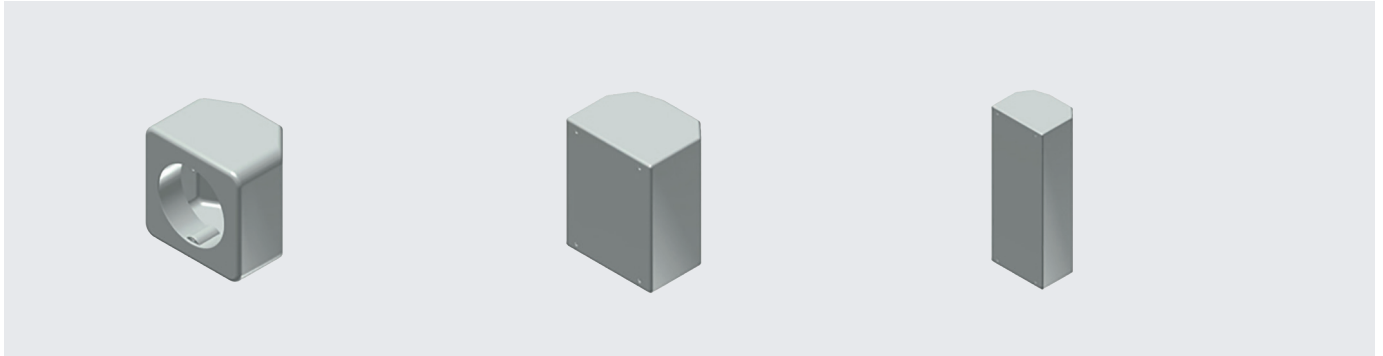

Console 1 unit made of plastic the same colour as the unit, W/H/D 94/94/65 mm with Ø 65 mm opening, e.g. for contactless readers.

Console 2 unit made of aluminium including front plate, the same colour as the unit, W/H/D 140/180/110 mm.

Console 3 unit made of aluminium including front plate, the same colour as the unit, W/H/D 140/365/110 mm.

Installation variants

Installation variants using FGE-M01 as an example

Finished floor level

Sub floor level

Sleeve foundation

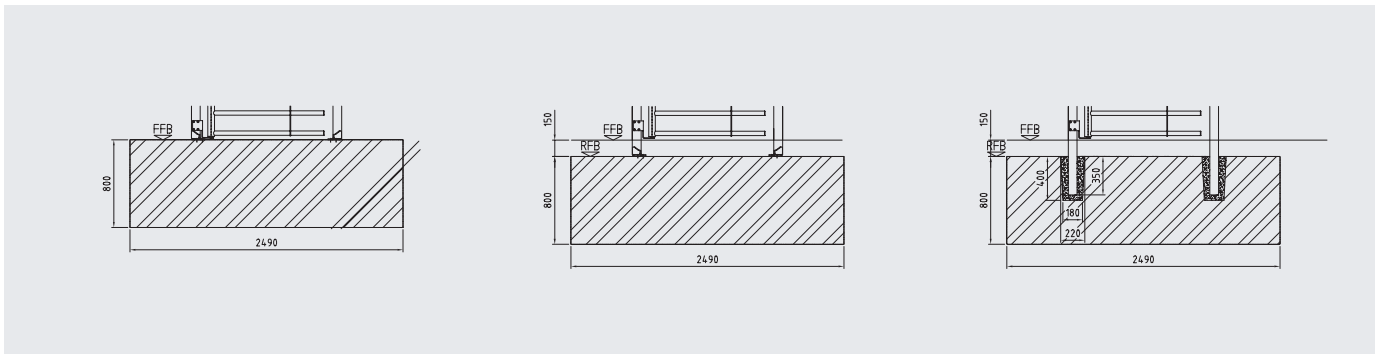

Installation variants using FTS-E02 as an example

Finished floor level

Sub floor level

Sleeve foundation

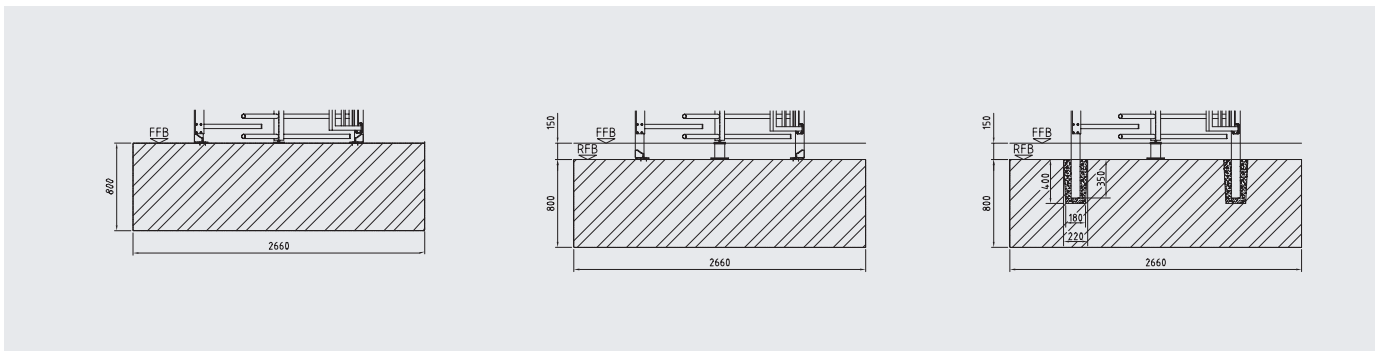

All dimensions in mm



Door
Hardware



Electronic
Access & Data



Mechanical
Key Systems



Lodging
Systems



Entrance
Systems



Interior Glass
Systems



Safe
Locks



Service

Our Sustainability Commitment

We are committed to fostering sustainable practices along our entire value chain in line with our economic, environmental and social responsibilities now and into the future. We seek to engage in open and transparent dialogue with all our stakeholders to develop strategies and actions based on clear targets and a continuous improvement approach, we will also actively report on our progress.



000440_November 2025 - Subject to change without notice

**dormakaba New Zealand
National Office**
Building P, 61-69 Patiki Road
Avondale, Auckland 1026
New Zealand

T: 0800 436 762
info.nz@dormakaba.com
dormakaba.co.nz

**dormakaba Australia
National Office**
12-13 Dansu Court
Hallam VIC 3803
Australia

T: 1800 675 411
info.au@dormakaba.com
dormakaba.com.au

Important information

This Technical Product Guide is intended to provide general information on the installation of dormakaba products and should not be used as a substitute for professional advice. There are many variables that can influence construction projects which affect whether a particular construction technique is appropriate. Before proceeding with any project, we recommend you obtain professional advice to ascertain the appropriate construction techniques to suit the circumstances of your project. We recommend you use qualified tradespersons to install these products. As of November 2025.

The printed colours indicating the surface finishes are not 100% accurate, but do provide a useful guide. Statements made with regard to the nature or use of the products are for the purposes of descriptions. Assent with regard to the existence of particular properties or particular uses always requires special written agreement. Pictures may show special designs which are different to the standard scope of delivery.