



**Door
Hardware**



**Entrance
Systems**



**Electronic
Access & Data**



**Interior Glass
Systems**



**Mechanical
Key Systems**



Service

dormakaba
International Holding AG
Hofwissenstrasse 24
CH-8153 Rümlang
T +41 44 818 90 11
info@dormakaba.com
www.dormakaba.com



CS 80 MAGNEO

Automatic sliding
door operator

Table of contents

- 03** **CS 80 MAGNEO –**
An unrivalled automatic sliding door operator
- 04** **Magnetic technology is silent –**
MAGNEO will give the proof
- 05** **Self-service provides high comfort**
- 06** **The intelligent solution for barrier-free WC applications**
- 08** **CS 80 MAGNEO –**
Our modular system appears to be that simple. It is!
- 10** **A folding ruler is enough to plan the single-leaf system**
- 12** **That's all you need**
Required installation dimensions
- 14** **Glaziers and joiners should keep these dimensions in mind**
- 16** **Simple planning for double-leaf systems**
- 18** **Which components are needed for the double-leaf system?**
- 20** **Glaziers and joiners should keep these dimensions in mind**
- 24** **Four steps to create your door system**
Then everything will work automatically.

CS 80 MAGNEO – An unrivalled automatic sliding door operator

Outstanding user convenience and unique driving behaviour excel with the automatic sliding door operator CS 80 MAGNEO. Based on their linear induction technology, dormakaba designed an easy-to-handle operator system for many kinds of interior sliding doors.

dormakaba's elegant Contur design is characteristic for the CS 80 MAGNEO. Thanks to its slender and linear construction in conjunction with two design versions, CS 80 MAGNEO perfectly matches the overall architecture of the building to harmonise with further integrated dormakaba solutions – both in the private and the public sector.

Superior design

In order to meet the high aesthetic demands of interior design, CS 80 MAGNEO is available in two different and selectable surface finishes. In its standard version in anodised aluminium, the magnetic sliding door operator ensures visual unity with other products out of dormakaba's Automatic range. As an alternative, users may choose a stainless steel version in matt finish. This stainless steel surface finish perfectly matches dormakaba Glass applications to create visual unity and a harmonious overall look.

NEW Now available for double-leaf doors: For large opening widths the CS 80 MANGEO can be installed as a double-leaf system with the same functionality as the single-leaf version.

Suddenly anything is possible

Thanks to the flexibility of this new system, the CS 80 MAGNEO opens up various fields of application – both in the private and the commercial sector. No matter if installed as an interior door, as an access door of a walk-in cup-board or as a prestigious entrance door to an office or practice, the CS 80 MAGNEO is extremely versatile. It is suitable for in-wall or on-wall mounting and may be realised as left- or right-handed versions. For professionals and the competent handyman, this automatic sliding door operator is straightforward to install and easy to operate, making it the preferred solution, especially for existing door systems which may be upgraded with the aid of the automatic CS 80 MAGNEO operator.

Safe – CS 80 MAGNEO

In Low-Energy-Mode, extra-sensitive driving characteristics respond immediately to any obstacle, thereby ensuring excellent protection as the rule from a Low-Energy door in accordance with EN16005. DIN 18650 (German Industrial Standard) and ANSI (American

Standard) and BSI (British Standard), may be operated without sensors. When Full-Energy-Mode is activated at the operator, the CS 80 MAGNEO benefits from seamless integration with the dormakaba system. In this case, the CS 80 MAGNEO must be equipped with safety sensors from the dormakaba Automatic range of accessories. sensors from the dormakaba Automatic range of accessories.

Functions

Whichever way you would like to open the door in a full-automatic way via motion detector, manually, via pushbutton or if you would like to adjust the door so that it is permanently open, the CS 80 MAGNEO already provides a large range of standard functions. It may be activated via push-button, radar motion detector, radio remote control, Push&Go, manually and adjusted to Permanent Open Function or Full-Energy-Mode (in Full-Energy Mode additional safety sensors are required).

NEW Also usable as a solution for barrier-free WC applications.

Mounting

In many cases, mounting the CS 80 MAGNEO does not require any specialist knowledge. Comprehensive mounting and operating instructions mean that the mounting can be performed by a glass, metal or timber worker and even a competent handyman.



Magnetic technology is silent – MAGNEO will give the proof

A technology that is suitable for everyday business and that you hardly notice, thanks to its almost silent and reliable function.

The CS 80 MAGNEO is driven magnetically by contactless shear wave from a linear DC motor – a movement that perfectly matches that of a sliding door.

The functional principle of the CS 80 MAGNEO is simple: Its silent operating behaviour makes the system especially suitable for areas where a low noise level is required: Everywhere.

Technical specifications

Operator length	without cover	with cover
Length version LV1	1,750 mm	1,840 mm
Length version LV2	2,000 mm	2,090 mm
Length version LV3	2,250 mm	2,340 mm
Operator lengths double-leaf version	without cover	with cover
Length version LV1	3,600 mm	3,690 mm
Length version LV2	4,100 mm	4,190 mm
Length version LV3	4,600 mm	4,690 mm
Operator height		
With MANET single-point fixings		62 mm
With glass clamping rail		75 mm
With wooden door panel		75 mm
Overall depth		
On-wall mounting (without chuck flange)		63 mm
In-wall mounting (only operatorsprofil)		50 mm
Operator weight		
Length version LV1		8.6 kg
Length version LV2		9.4 kg
Length version LV3		10.2 kg
Door leaf weight		20–80 kg
Speed		0,2–0,6 m/s
The speed is calculated with the aid of the driving path and the door panel weight. During the commissioning, the system will adjust automatically in accordance with the prevailing standards and regulations.		
Power supply	220–230 V AC ± 10% 50/60 Hz	
Fuse protection, by others	10 A	

The functional principle of MAGNEO

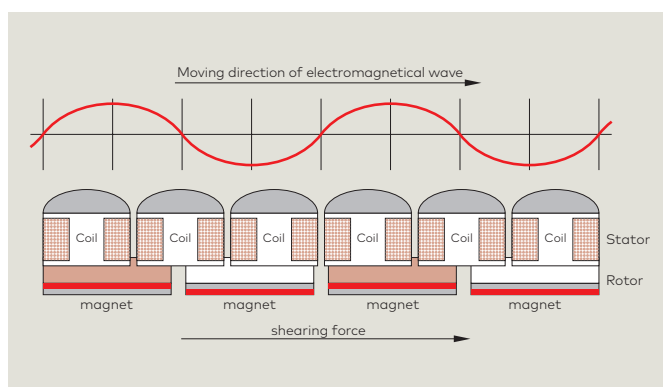

Power consumption	
Stand-by-mode	3,7 W
Automatic Function	max. 60 W
Class of protection	IP 20
Temperature range	0–40 °C
Required operating conditions	
Only suitable for dry environments	Relative humidity max. 93 % non-condensing
Operating noise	max. 55 dB(A)
Measured at test setup. The noise level depends on the door and the prevailing substructure.	
Low-Energy-Mode	●
Full-Energy-Mode with safety sensor	●
Compliant with DIN 18650 and EN 16005, ANSI, BSI	●
Manufactured to ISO 9001	●
Connectable accessory	
Pushbutton, radio remote control and radio switch	●
Motion detector	●
External program switches	●
Safety sensors for main and secondary closing edge	●
● = yes ○ = optional	



Self-service provides high comfort



The CS 80 MAGNEO is easy to handle. This automatic sliding door operator offers all important standard functions and various special functions for your convenience.

User comfort that will open doors for you: either in a full automatic way via motion detector, pushbutton (either with cable or wireless), radio remote control or with the aid of our smooth Push&Go Function. No matter how you open the door – all functions are freely selectable: the hold-open time, Permanent Open and automatic closing.

Very simple and simply beautiful!

Series functions as standard



Push&Go

The door opens as soon as the door is slightly pushed in opening direction by hand and closes automatically on expiry of the individually adjustable hold-open time.



"SoftMotion" safety

The system is delivered in Low-Energy-Mode as standard so that the door will stop and reverse automatically on the slightest contact.



Manual access

Although the CS 80 MAGNEO is a full-automatic operator, it may effortlessly be opened and closed manually in the event of a power failure.

Plenty of accessories for those who want even more



Pushbutton

The CS 80 MAGNEO is activated via pushbutton. The sliding door will close automatically as soon as the user has passed the door system.



Radio remote control

A CS 80 MAGNEO operator with a BRC radio remote system may be opened and closed with the aid of a BRC-H radio remote control.



Motion detector

A motion detector is suitable to open the CS 80 MAGNEO in a full-automatic way.



Program switch

You may comfortably switch between the different operation modes (Automatic, Permanent Open and manual operation) with the aid of the internal program switch or the wall-mounted EPS-S3 program switch.





The intelligent solution for barrier-free WC applications



There are varied requirements for barrier-free toilet facilities concerning to the different specifications for public and private spaces, particularly in terms of comfortable access, easy handling, whilst observing privacy and emergency solutions.

The dormakaba Sliding Door Operator CS 80 MAGNEO can be activated extremely easily, thus making it significantly more user-friendly for people with disabilities or limited mobility.

System components for this type of installation	Order no.
 Disabled access button	05157433332 16717701170*
 Push button "door open" Stainless steel button	05157033332 16717601170*
 Magic Switch Contactless radar push button, concealed mounting incl. flush-type box (for system 55), additional blind cover 56398110 required	05076831332
 Push button "door lock" Stainless steel button with symbol "locked/opened"	05156933332 16718101170*
 Status display Light signal red/green 24 V DC, white, concealed mounting, system 55	16713401170
 Status-display Light signal 24 V DC, LED status display red/green/white 24 V, luminosity according to DIN VDE 0834, part 1	05111631332
 Key button Key button KT 1-3, concealed mounting, incl. euro profile half-cylinder, aluminium, metal	05054531332
Emergency stop push button Push button with optical display of lock state, concealed mounting, system 55	056330500
 Central insert Suitable for system 21 and system 55, concealed mounting	05157633332

Framework programm for system components	Order no.
 Cover frame single	05157833332** 05214233332*
 Cover frame double	05210633332** 05214333332*
 Cover frame triple	05210733332** 05214433332*
 Cover frame quadruple	05210833332** 05214533332*

* System 55: For the launch pls. contact your sales person. Please note that system 55 covers can not combined with the old system 21 switch inserts.

** When installing system 55 switch inserts (i.e. status display, program switch, key button, emergency switch) the adapter frame 05210933332 must be ordered per insert.

Facility equipment

Different requirements result in optimised solutions using the WC control unit

WC control unit in public spaces with locking device

The door is equipped with a CS 80 MAGNEO featuring a locking device. Flat pushbuttons for activation are mounted internally and externally. Internally there is also a flat pushbutton to control the locking device. For "engaged/vacant" displays, a status display (red/green) will be shown externally and internally. An emergency opening device

can be optionally mounted externally to allow the door to be opened quickly in an emergency. dormakaba also recommends integrating the barrier-free WC with an on-site emergency call system.

WC vacant	Externally-installed status display is green
Entry	Open door with button, door closes following pre-set hold-open time
Locking device	Activate the locking device button, the door locks mechanically and cannot be opened using the external button, status display changes from green to red
Exit	Door opens following activation of the locking device button, status display changes from red to green, door closes following pre-set hold-open time
Emergency opening	In case of emergency, the locking device can be released by activating an emergency switch or key switch, the door then opens automatically
Safety	The door is automatically unlocked in the case of a power failure and can be opened by hand

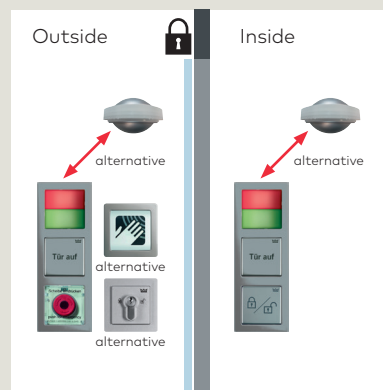

WC control unit in private spaces With keep-shut function

The door is equipped with a CS 80 MAGNEO without a locking device. Flat pushbuttons for activation are mounted both internally and externally. Internally there is also a flat pushbutton to activate the keep-close function. For "engaged/vacant" displays,

a status display (red/green) can optionally be mounted externally and internally.

WC vacant	Optional status display is green
Entry	Open door with button, door closes following pre-set hold-open time
Locking device	Activate locking device button, optional status display goes red, the door presses permanently shut and cannot be opened using the external button
Exit	Door opens following activation of the locking device button, status display changes from red to green, door closes after pre-set hold-open time
Emergency opening	In case of emergency, the door can be pushed open by hand from the outside. This requires a powerful push, and the door will automatically open up after 50 cm (Push&Go)
Safety	The door can be opened by hand in the case of a power failure

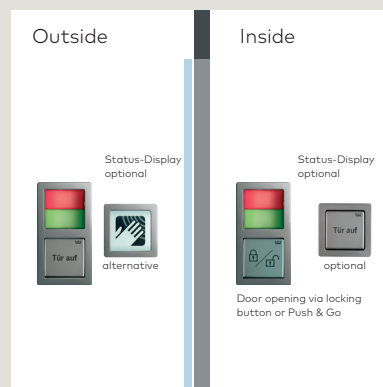

CS 80 MAGNEO – Our modular system appears to be that simple. It is!

CS 80 MAGNEO is a modular system consisting of door kits, cover and fixings kits, the CS 80 MAGNEO operator and accessories.

The system allows virtually any door to be configured as an automatic sliding door. The overview right illustrates which system components are required.

**Wooden door /
frame door
(on-wall)**



**Glass door /
glass clamping rail
(on-wall)**



**Glass door / MANET
single-point fixings
(on-wall)**



The respective door kits contain all components that are required to mount the CS 80 MAGNEO operator onto the door panel for the prevailing way of mounting.

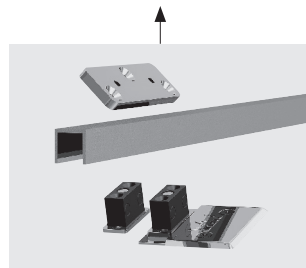

**Door kit for wooden
door panel**

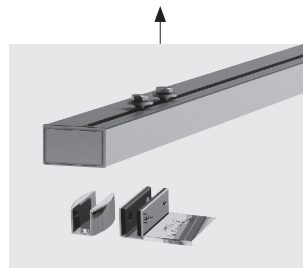

**Door kit glass
clamping rail**

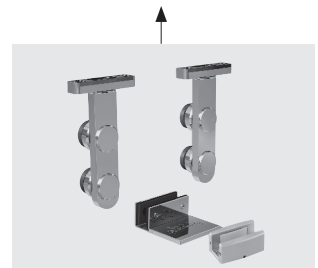

**Door kit
MANET**

+

+

+

You will require an additional cover and fixing set if you want to mount the CS 80 MAGNEO operator on the wall.

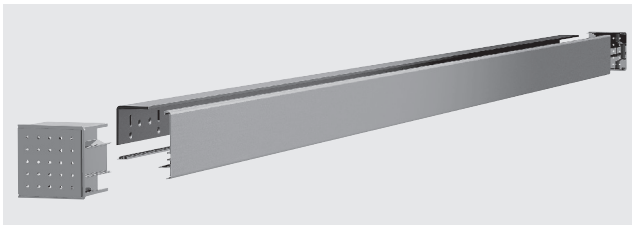

**Cover and fixing kit for wooden door panels and glass
clamping rails**

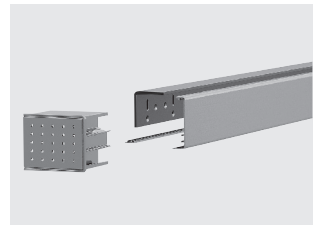

**Cover and fixing kit
for MANET**

+

+

The CS 80 MAGNEO operator is the basis for any application. It is available in three lengths in order to cover different door widths.

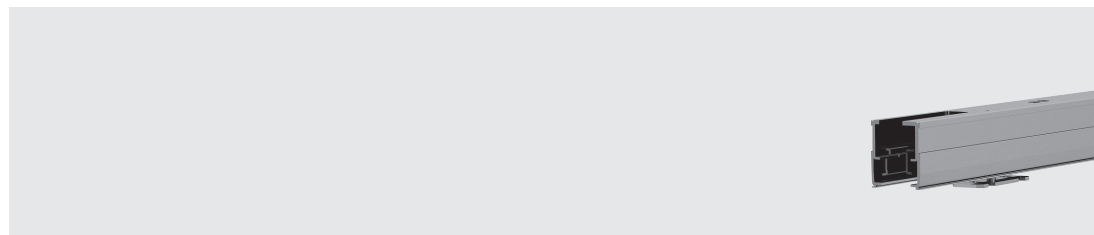

CS 80 MAGNEO operator incl. set for in-wall mounting

You may choose the CS 80 MAGNEO in two different surface finishes:

- Standard version in anodised aluminium (E6/CO):
To match automatic dormakaba access systems in different designs
- Version in matt stainless steel design:
To meet other designs out of the dormakaba Glass product range

**Glass door /
glass clamping rail***
(on glass wall)



**Glass door / MANET
single-point fixings***
(on glass wall)



**Wooden door /
frame door**
(in-wall)



**Glass door /
glass clamping rail**
(in-wall)

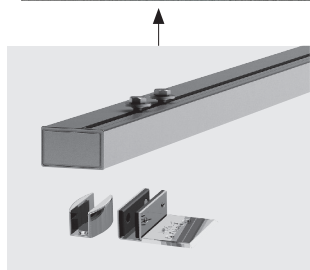
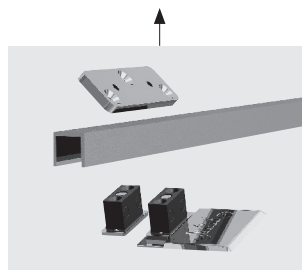
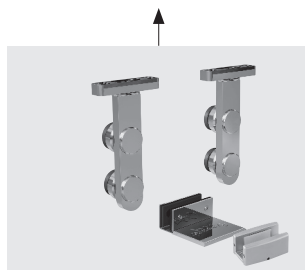
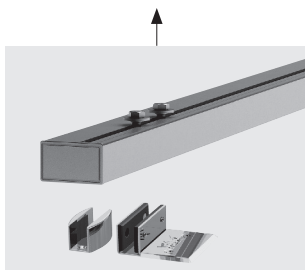
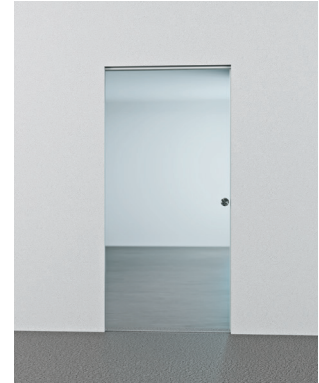

**Door kit glass
clamping rail**

Door kit MANET

**Door kit for wooden
door panel**

**Door kit glass
clamping rail**

+

+

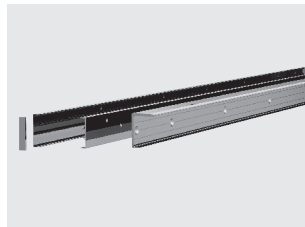
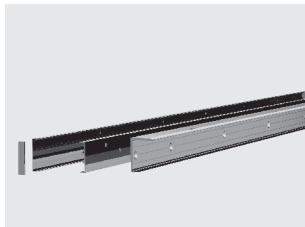

Glass fixing system

Glass fixing system

+

+

+

+

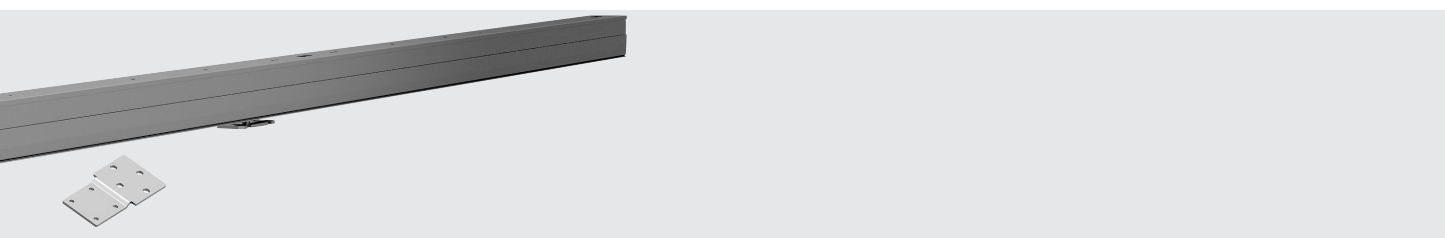

* Planning and mounting by a specialist firm only.

Ways of mounting

- In-wall mounting (Aperture mounting)
- On-wall mounting (Surface mounting)

Passage widths

From 650 to 1,060 mm. The CS 80 MAGNEO operator, the fixing kit and cover kit as well as the glass clamping rail kit are available in three different lengths.

Available door panel versions

- Full-glass doors
 - Framed glass doors
 - Wooden doors (solid-leaf construction)
 - Metal doors
 - For door panel weights from 20 to 80 kg
- The door panel must be ordered separately.

Activation of opening/closing cycle

- Full-automatic via motion detector
- Via touch (Push&Go)
- Pushbutton
- Hand-held transmitter
- Locking device

A folding ruler is enough to plan the single-leaf system



Operator length and driving path

The length of the CS 80 MAGNEO operator depends on the length of the door's driving path (F) – which describes the distance the door has to cover for its opening or closing cycle. The respective formula is blindingly easy:

$$\begin{aligned} & \text{Passage width DB} \\ + & \text{ Door panel projection } A^B \\ = & \text{ Driving path F} \end{aligned}$$

We offer the CS 80 MAGNEO in three different lengths LV 1-3:

- LV1** for driving paths F of up to 875 mm,
- LV2** for driving paths F of up to 1,000 mm,
- LV3** for driving paths F of up to 1,125 mm.

A^B = door panel projection

The door panel projection is freely selectable. It may however not exceed 65 mm and is calculated with the aid of the passage width DB and the door panel width B:

$$(\text{Door width B} - \text{DB}) / 2 = A^B$$

Space requirement for operator including cover + end caps

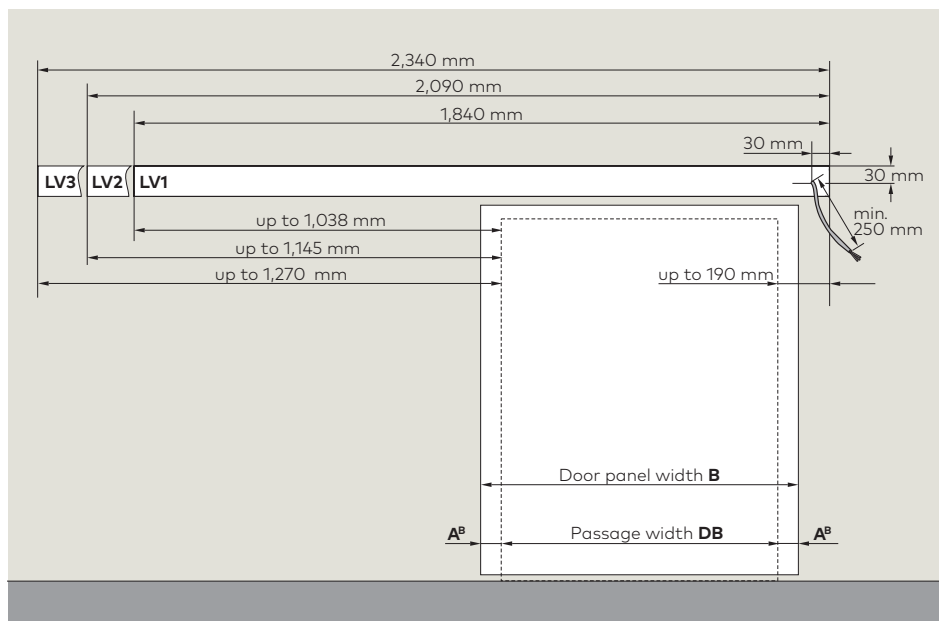

The sliding door on the drawing opens to the left side, thus the power supply is connected on the right side of the door (mains connection 3 x 1.5 mm²). The power supply of door systems opening to the right thus has to be realised on the left side of the operator.

Reach your target with the proper dimensions

On-wall mounting

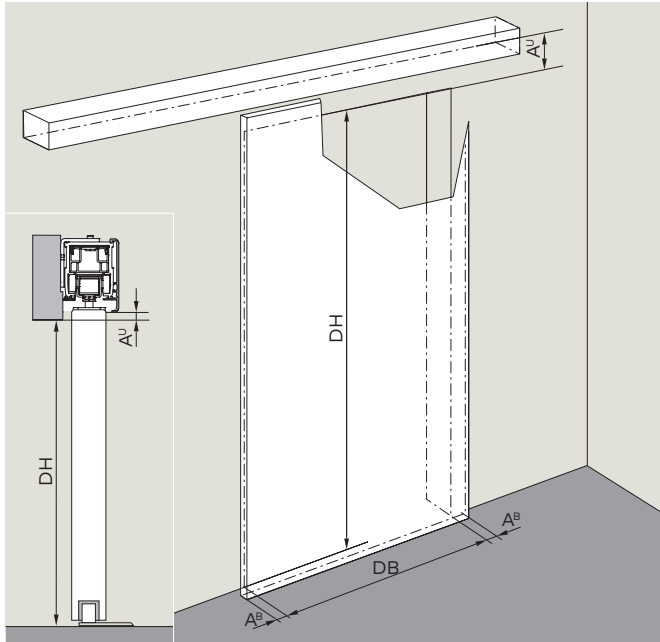

In-wall mounting

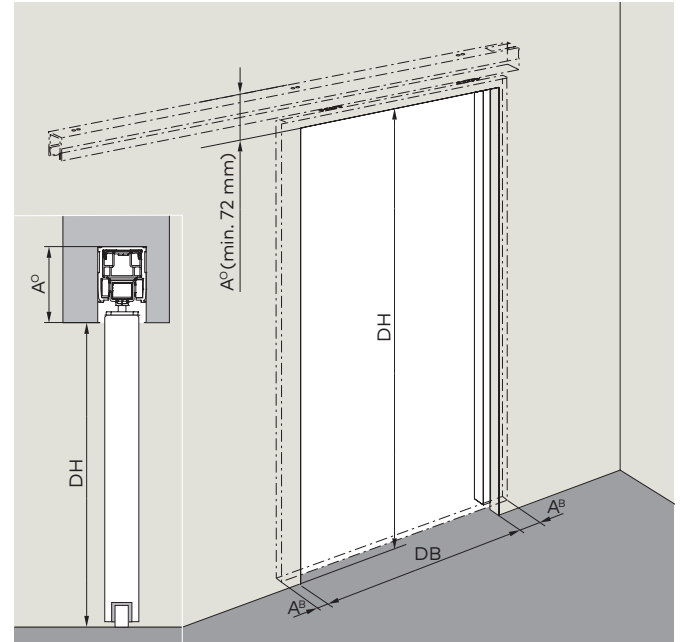

Power supply

The opening direction of the sliding door determines where the power supply (mains connection) is connected at the CS 80 MAGNEO. The cable that comes out of the wall should at least be 250 mm long. See drawing at bottom of page 8.

A^u = Bottom edge of operator

A^u describes the distance between the bottom edge of the CS 80 MAGNEO operator and the passage. You may select the dimension according to your requirements and will require it when planning your CS 80 MAGNEO as an on-wall mounted version.

DH & DB

The passage height DH and the passage width DB have to be determined when planning an automatic CS 80 MAGNEO sliding door system.

A^o = Upper edge of operator

A^o describes the distance between the upper edge of the operator and the passage. You may select the dimension according to your requirements and will require it when planning your CS 80 MAGNEO as an in-wall mounted version.

CS 80 MAGNEO systems with door frame or baseboard projection (AW-dimension)

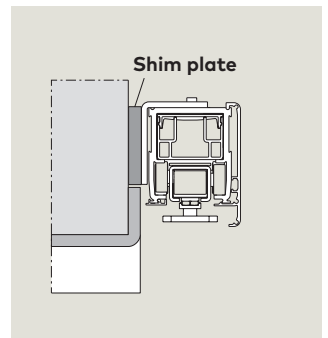
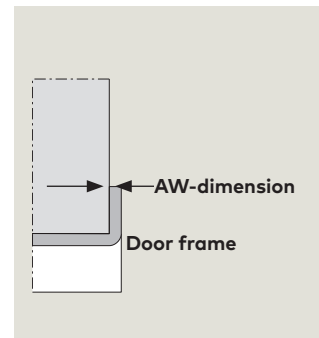
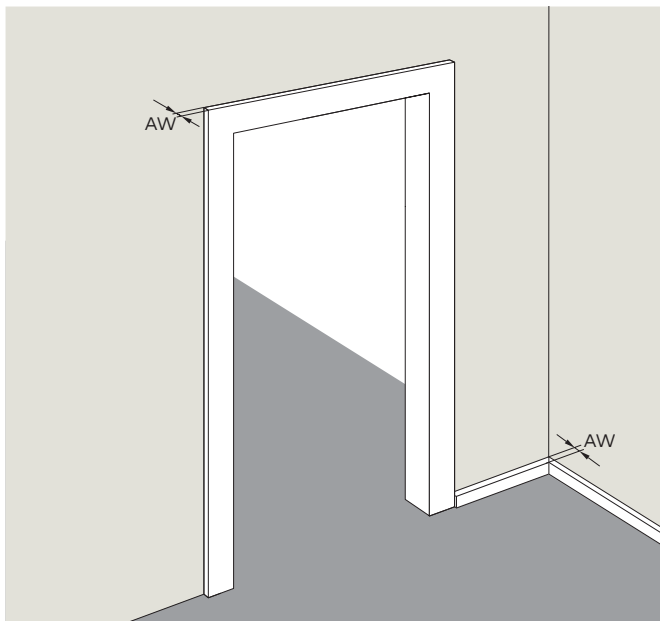

Is there a door frame or baseboard? If so, how big is the projection of the frame/baseboard with regard to the surface of the wall (AW) at its biggest point? In case the AW-dimension (projection) is bigger than 3 mm, you will have to shim the CS 80 MAGNEO operator. dormakaba offers a special shim plate for this purpose. In case the AW-dimension (projection) is bigger than 15 mm, the operator additionally has to be shimmed by others.

That's all you need – Required installation dimensions

When planning an automatic CS 80 MAGNEO door system, you may for example start with the door panel in order to create a smooth look with regard to the passage or to use an existing door panel.

It is often reasonable to concentrate the planning on the fixing points of the operator as the fixing options provided by others are limited.

Wooden door / frame door (on-wall)

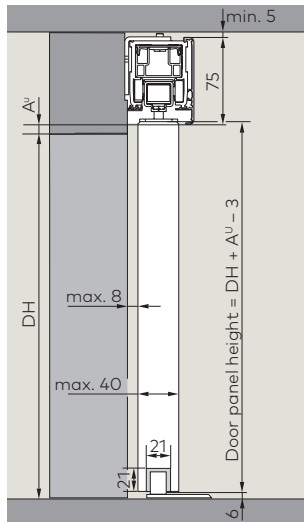

Glass door / glass clamping rail (on-wall)

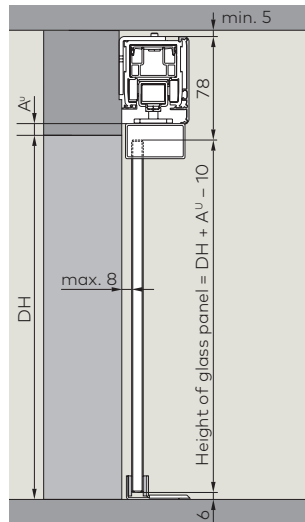

Glass door / MANET single-point fixings (on-wall)

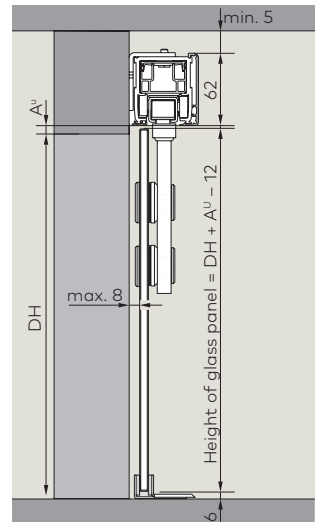

	LV1	LV2	LV3	LV1	LV2	LV3	LV1	LV2	LV3
A. Door kits	84000071						84000078		
E6/C0				840000-79	-80	-81			
Matt stainless steel design				840000-82	-83	-84			84000077
Stainless steel									84000072
B. Cover and fixing kit									
E6/C0	8400005-1	-2	-3	8400005-1	-2	-3	8400006-1	-2	-3
Matt stainless steel design	8400005-4	-5	-6	8400005-4	-5	-6	8400006-4	-5	-6
Optional shim plate if AW (projection) = 3 to 15 mm	8402012-4	-5	-6	8402012-4	-5	-6	8402012-4	-5	-6
C. CS 80 MAGNEO operator	8401000-1	-2	-3	8401000-1	-2	-3	8401000-1	-2	-3
D. Cover and fixing profiles									
Cover profile for glass-fixing system 62 mm									
E6/C0									
Matt stainless steel design									
Cover profile for glass-fixing system 75 mm									
E6/C0									
Matt stainless steel design									
Internal cover for glass-fixing system 62 mm									
E6/C0									
Matt stainless steel design									
Internal cover for glass-fixing system 75 mm									
E6/C0									
Matt stainless steel design									
Fixing profile for glass-fixing system									
Set for on-glass-wall mounting									
E6/C0									
Matt stainless steel design									

Additional accessories and order no. please see page 22. *The system may only be planned and mounted by a properly qualified person.

The CS 80 MAGNEO is a modular system.

Combine your system components based on your installation requirements:

CS 80 MAGNEO operator plus door kit and in case of on-wall mounting: plus cover kit and fixing kit. For some system components you must select the correct length version LV1 – LV3. The table shows which system components and kits are required for each way of mounting. Please note the article numbers in the ordering guide below.

The CS 80 MAGNEO operator, the fixing kit and cover kit as well as the door kit with glass clamping rail are available in three different lengths. The required length is determined via the driving path.

- LV1** for driving paths F of up to 875 mm
- LV2** for driving paths F of up to 1,000 mm
- LV3** for driving paths F of up to 1,125 mm

Driving path F = passage width DB + door panel projection A^B

DB =

A^B =

F =

LV1 LV2 LV3

Driving path: on-wall mounting

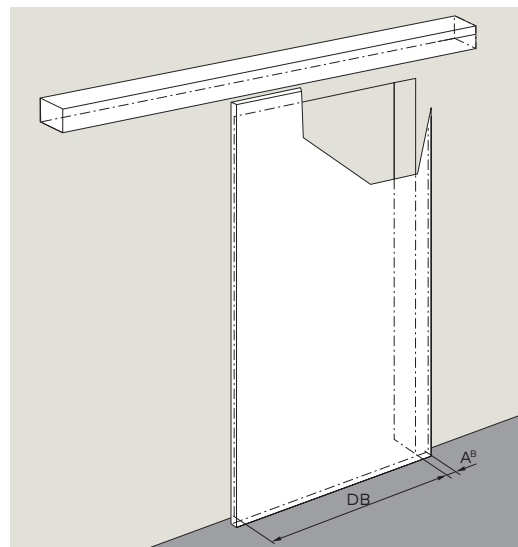

Glaziers and joiners should keep these dimensions in mind

How to order the door panel

The door panel is not a component of the CS 80 MAGNEO modular system, you may place your order with a glazier or joiner.

- **Door panel width** is freely selectable between 780 mm and 1,190 mm. The door panel projection (A^B) must however not exceed 65 mm. (See page 8)
- **Door panel height** is freely selectable (max. 2,500 mm) and calculated with the aid of the mounting height of the operator.
- **Glass door panels** have to be made of safety glass and all glass edges have to be rounded off.
- **Door panel weight** from 20 to 80 kg.
- Wooden door panels and glass doors with MANET single-point fixings must be provided with drill holes and recesses before the system is mounted. The required **C-dimension** results from the prevailing length version (LV) of the operator:
LV 1: C = 575 mm
LV 2: C = 700 mm
LV 3: C = 825 mm

Preparation of wooden door panel

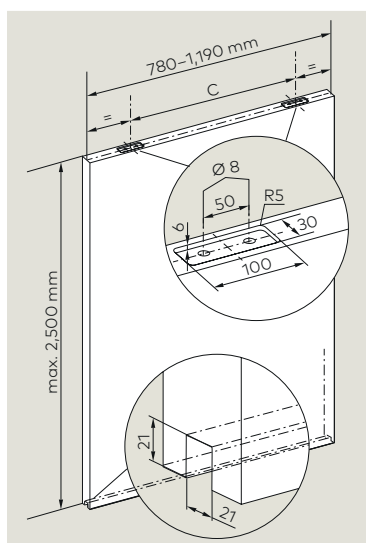

Glass door panel with glass clamping rail

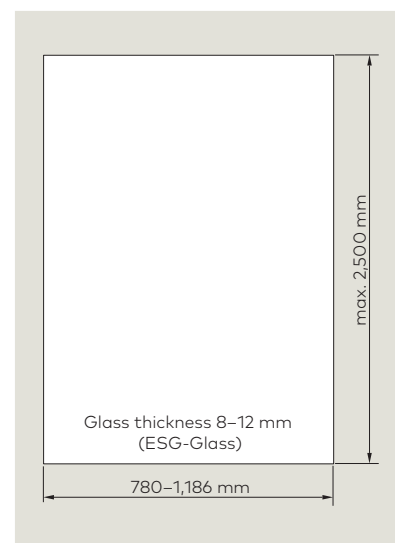

Driving path: in-wall mounting

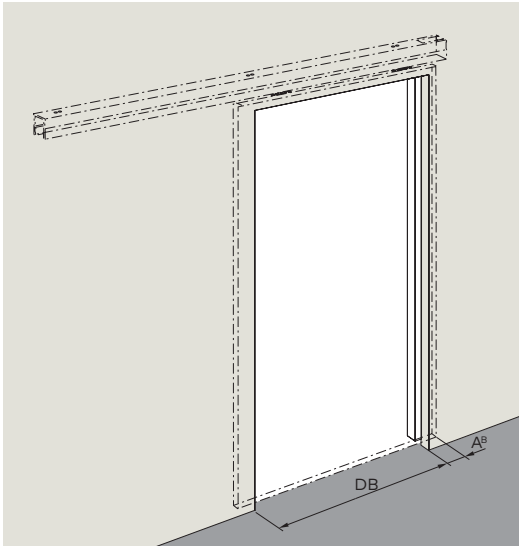

Determining the maximum AW-dimension (projection)

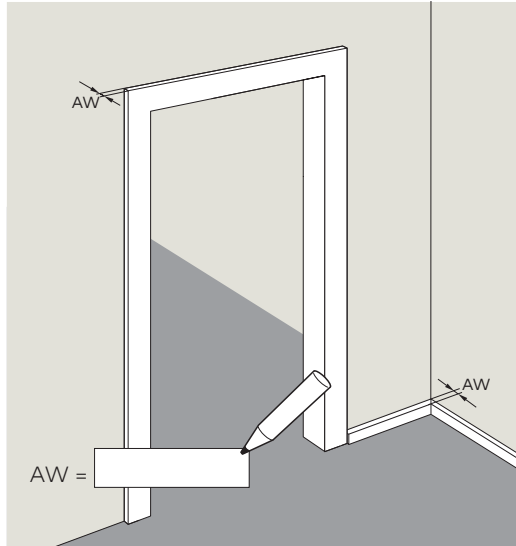

CS 80 MAGNEO: Risk for the facility operator and risk assessment

The risk of crushing, shearing, impact and drawing in must not be excluded with automatic doors. When the system is delivered (in Low-Energy-Mode), the CS 80 MAGNEO meets the requirements of DIN 18650 and EN 16005. By complying with these provisions, such as reduced driving speeds and contact forces, the system generally provides a high safety standard so that sensors are not required as a rule. At the discretion of the operator or installer and depending on the spatial conditions and persons using the door, it may be advisable

to use safety sensors even when the system is operated in Low-Energy-Mode, for instance if being used by children or infirm persons. For this purpose, a risk assessment must be carried out by a specialist when the door system is being planned and commissioned. It is at the operator's discretion whether or not a safety device is actually installed. In Full-Energy-Mode the use of additional safety sensors is obligatory.

Preparation of MANET glass door panel

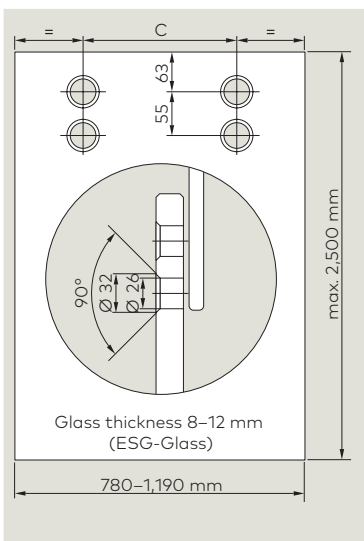

Preparation of optional recessed door grip

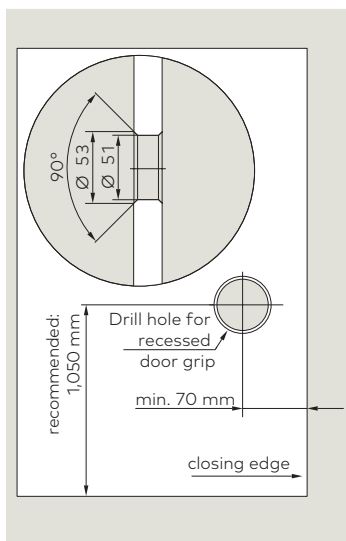

Hints regarding in-wall mounting

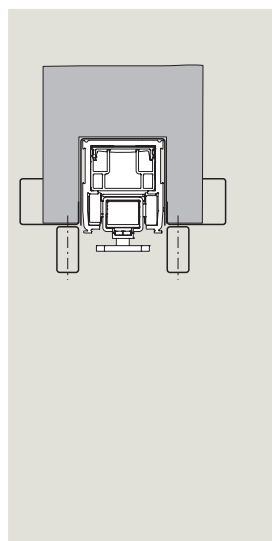

We would recommend covering the door panel connection at the CS 80 MAGNEO operator with profiles so that you will be able to access the operator easily even after the wall has been closed.

Simple planning for double-leaf systems



With the double-leaf CS 80 MAGNEO system passage widths (DB) from min. 1,500 mm up to max. 2,250 mm can be realised.

- LV1:** DB = 1,500 mm up to 1,750 mm
- LV2:** DB = 1,750 mm up to 2,000 mm
- LV3:** DB = 2,000 mm up to 2,250 mm

Operator length and driving path

The length of the CS 80 MAGNEO operator depends on the length of the door's driving path (F) – which describes the distance the door has to cover for its opening or closing cycle. For the double-leaf system the driving path F describes the driving path of one door leaf.

Driving path for each door leaf:

$$\text{Driving path } F = \text{passage width } DB/2$$

We offer the CS 80 MAGNEO in three different lengths LV 1-3:

- LV1** for driving paths **F** from 750 up to 875 mm each door leaf.
- LV2** for driving paths **F** from 875 up to 1,000 mm each door leaf.
- LV3** or driving paths **F** from 1.000 up to 1,125 mm each door leaf.

A^B = door panel projection

The door panel projection is freely selectable. It may however not fall below 40 mm and not exceed 65 mm.

Space requirements for operator including cover + end caps

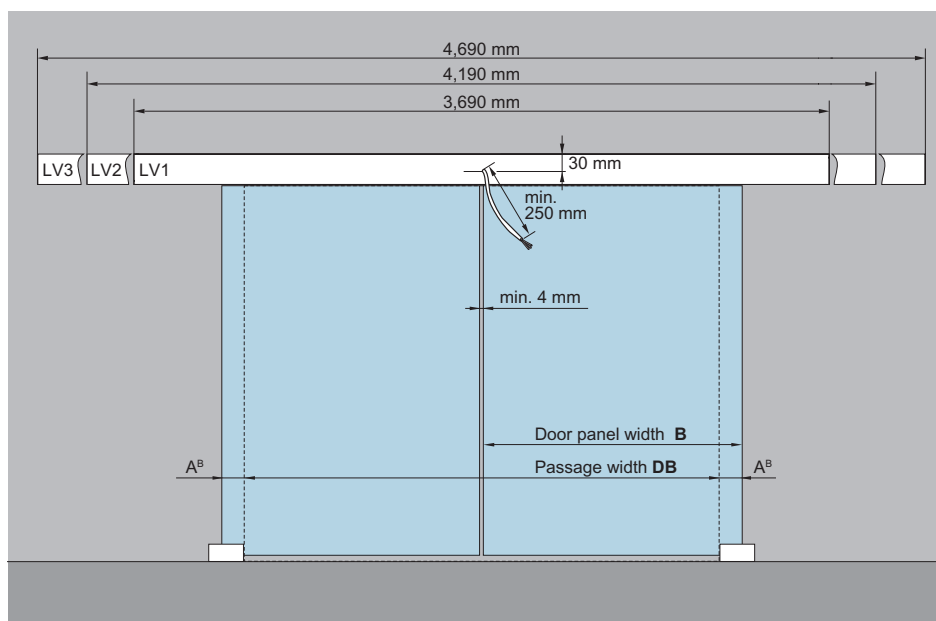

The drawing shows a double-leaf system, the power supply of double-leaf door systems (mains connection 3 x 15 mm²) has to be realised in the centre between both operators.

Reach your target with the proper dimensions

On-wall mounting

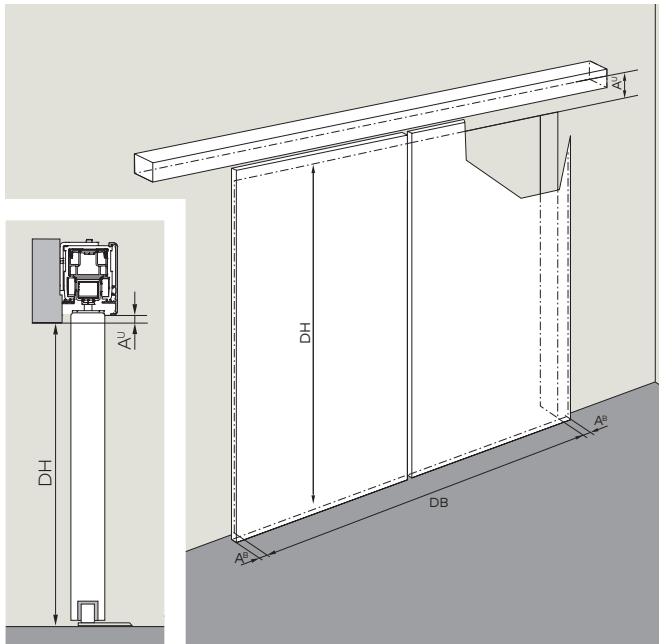

In-wall mounting

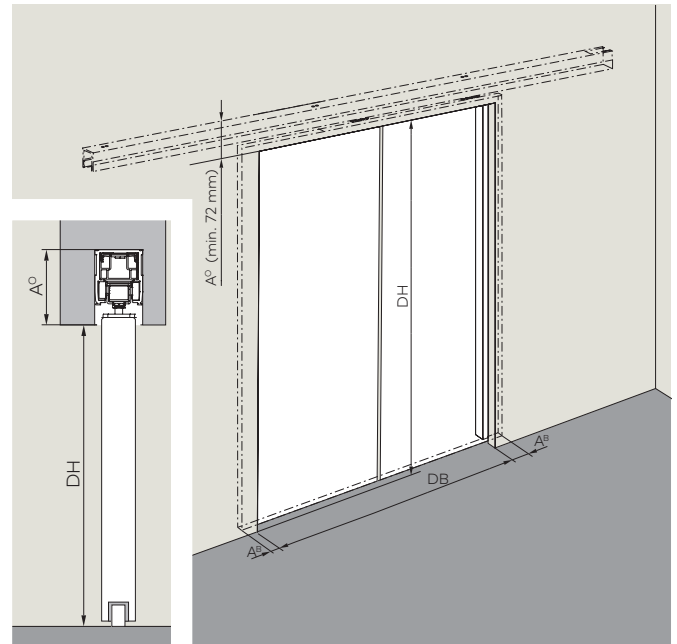

Power supply

The power supply (mains connection) is positioned in the centre between both operators. The cable that comes out of the wall should at least be 250 mm long. See drawing at bottom of page 16.

A^U = Bottom edge of operator

A^U describes the distance between the bottom edge of the CS 80 MAGNEO operator and the passage. You may select the dimension according to your requirements and will require it when planning your CS 80 MAGNEO as an on-wall mounted version.

DH & DB

The passage height DH and the passage width DB have to be determined when planning an automatic CS 80 MAGNEO sliding door system

A^O = Upper edge of operator

A^O describes the distance between the upper edge of the operator and the passage. You may select the dimension according to your requirements and will require it when planning your CS 80 MAGNEO as an in-wall mounted version.

CS 80 MAGNEO systems with door frame or baseboard projection (AW-dimension)

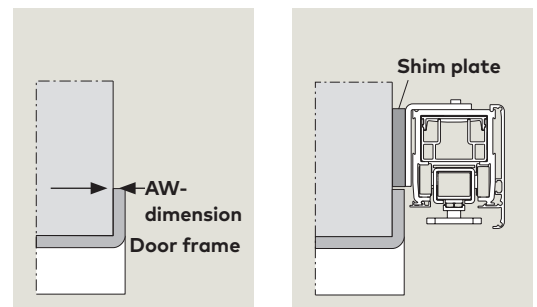
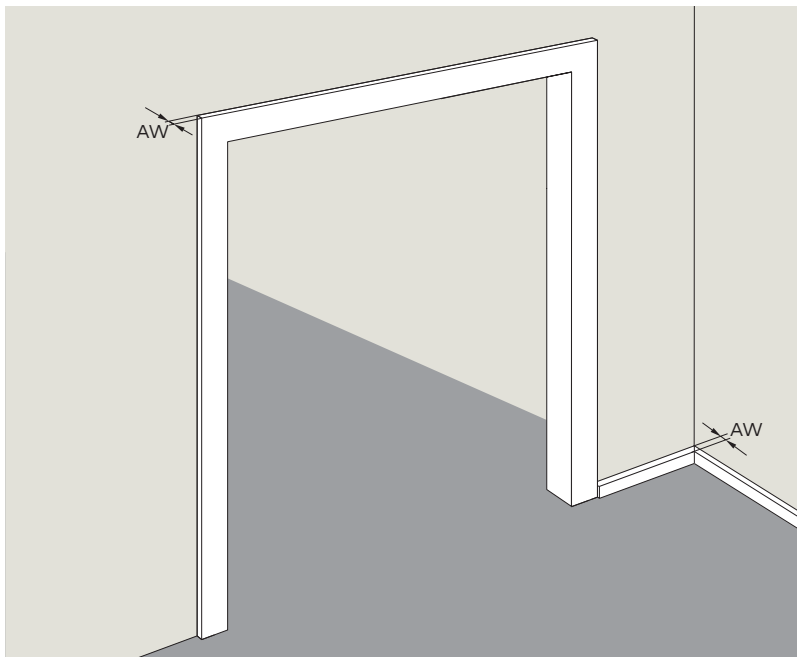

Is there a door frame or baseboard? If so, how big is the projection of the frame/baseboard with regard to the surface of the wall (AW) at its biggest point? In case the AW-dimension (projection) is bigger than 3 mm, you will have to shim the CS 80 MAGNEO operator. dormakaba offers a special shim plate for this purpose. In case the AW-dimension (projection) is bigger than 15 mm, the operator additionally has to be shimmed by others.

Which components are needed for the double-leaf system?

When planning an automatic CS 80 MAGNEO door system, you may for example start with the door panel in order to create a smooth look with regard to the passage or to use an existing door panel.

It is often reasonable to concentrate the planning on the fixing points of the operator as the fixing options provided by others are limited.

**Wooden door/
frame door**
(on-wall)

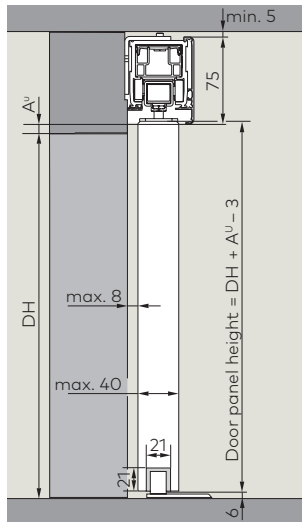

**Glass door/
glass clamping rail**
(on-wall)

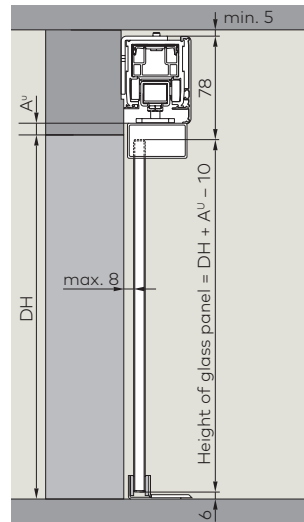
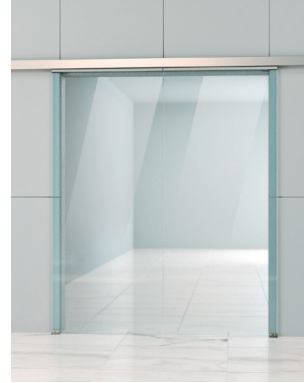

**Glass door/
MANET single-point fixings**
(on-wall)

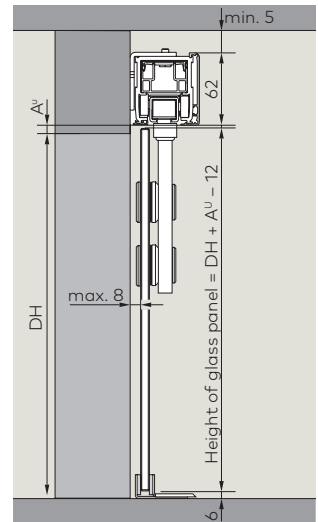
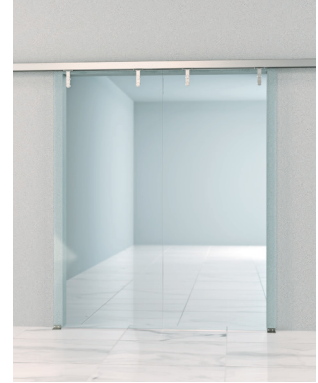

	LV1	LV2	LV3	LV1	LV2	LV3	LV1	LV2	LV3
A. Door kits²⁾		84000071							
E6/C0				840000-79	-80	-81			84000078
Matt stainless steel design				840000-82	-83	-84			84000077
Stainless steel									84000072
B. Cover and fixing kit									
Sync-Kit		84020131			84020131				84020131
Mounting angle E6/C0		84000067			84000067				84000067
Mounting angle		84000068			84000068				84000068
Matt stainless steel design									
Internal cover 62/75 mm E6/C0		34003005120			34003005120				34003105120
Internal cover 62/75 mm		34003007120			34003007120				34003107120
Matt stainless steel design									
C. CS 80 MAGNEO Operator²⁾	8401000-1	-2	-3	8401000-1	-2	-3	8401000-1	-2	-3
D. Mounting and fixing profiles									
Cover profile for glass-fixing system 62 mm									
E6/C0									
Matt stainless steel design									
Cover profile for glass-fixing system 75 mm									
E6/C0									
Matt stainless steel design									
Fixing profile for glass-fixing system									
Set for on glass wall mounting²⁾									
E6/C0									
Matt stainless steel design									

Additional accessories and order no. please see page 22.

* The system may only be planned and mounted by a properly qualified person. ** Two of each are required for double-leaf systems.

**Glass door/
glass clamping rail**
(on glass wall)*

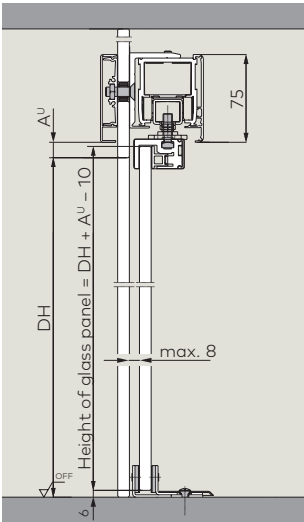

**Glass door/
MANET single-point fixings**
(on glass wall)*

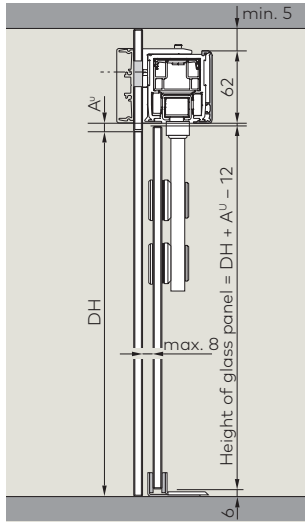

**Wooden door/
frame door**
(in-wall)

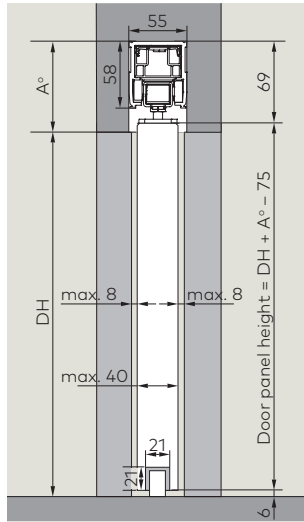

**Glass door/
glass clamping rail**
(in-wall)

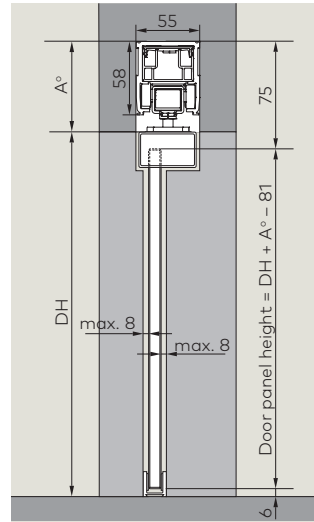

LV1	LV2	LV3	LV1	LV2	LV3	LV1	LV2	LV3	LV1	LV2	LV3
840000-79	-80	-81	84000078						840000-79	-80	-81
840000-82	-83	-84	84000077						840000-82	-83	-84
			84000072								
	84020131		84020131				84020131			84020131	
	84000067		84000067								
	84000068		84000068								
	34003005120		34003105120								
	34003007120		34003107120								
8401000-1	-2	-3	8401000-1	-2	-3	8401000-1	-2	-3	8401000-1	-2	-3
			34002902120								
			34002903120								
	34005102120										
	34005103120										
	34002801120		34002801120								
	84020006		84020006								
	84020007		84020007								

The CS 80 MAGNEO is a modular system.

Combine your system components based on your installation requirements: CS 80 MAGNEO operator plus door kit and in case of on-wall mounting: plus cover kit and fixing kit. For some system components you must select the correct length version LV1 – LV3. The table shows which system components and kits are required for each way of mounting. Please note the article numbers in the ordering guide below. The CS 80 MAGNEO operator, the fixing kit and cover kit as well as the door kit with glass clamping rail are available in three different lengths. The required length is determined via the passage width (DB).

LV1 DB = 1,500 mm up to 1,750 mm

LV2 DB = 1,750 mm up to 2,000 mm

LV3 DB = 2,000 mm up to 2,250 mm

Driving path: on-wall mounting

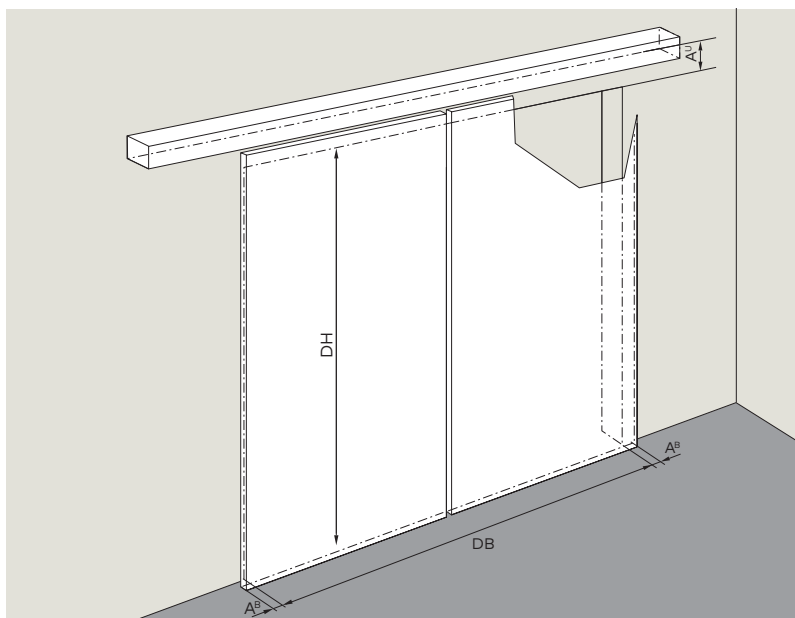

Glaziers and joiners should keep these dimensions in mind

How to order the door panel

The door panel is not a component of the CS 80 MAGNEO modular system, you may place your order with a glazier or joiner.

- **Door panel width** is freely selectable between 780 mm and 1,190 mm. The door panel projection (AB) must however not exceed 65 mm. (See page 8)
- **Door panel height** is freely selectable (max. 2,500 mm) and calculated with the aid of the mounting height of the operator.
- **Glass door panels** have to be made of safety glass and all glass edges have to be rounded off.
- **Door panel weight** from 20 to 80 kg.
- **Wooden door panels** and glass doors with MANET single-point fixings must be provided with drill holes and recesses before the system is mounted. The required **C-dimension** results from the prevailing length version (LV) of the operator:

LV 1: C = 575 mm

LV 2: C = 700 mm

LV 3: C = 825 mm

Preparation of wooden door panel

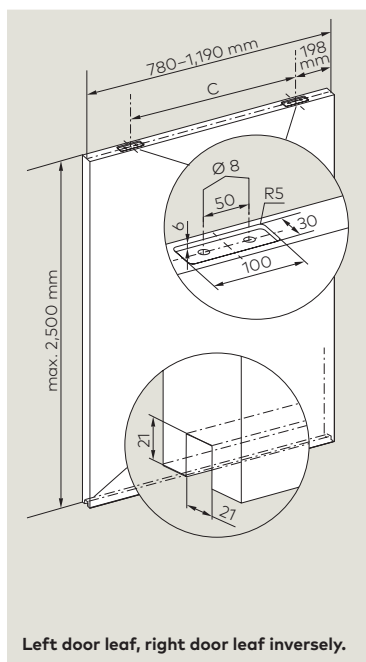

Left door leaf, right door leaf inversely.

Glass door panel with glass clamping rail

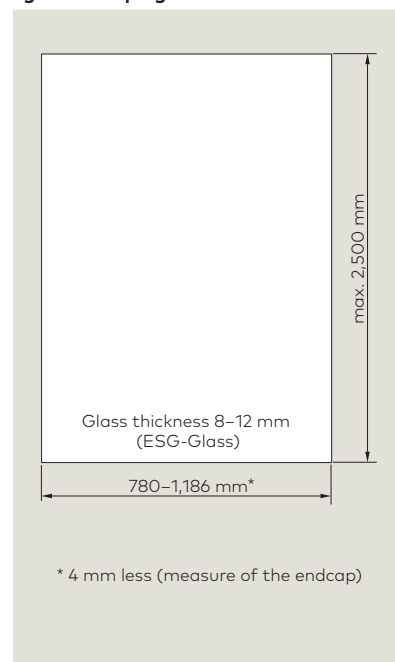

* 4 mm less (measure of the endcap)

Driving path: in-wall mounting

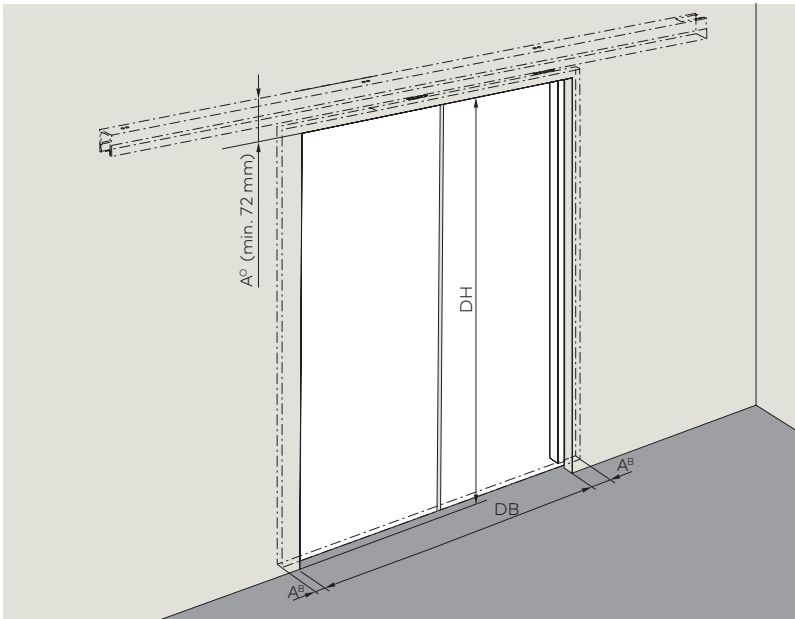

CS 80 MAGNEO: Risk for the facility operator and risk assessment

The risk of crushing, shearing, impact and drawing in must not be excluded with automatic doors. When the system is delivered (in Low-Energy-Mode), the CS 80 MAGNEO meets the requirements of DIN 18650 and EN 16005. By complying with these provisions, such as reduced driving speeds and contact forces, the system generally provides a high safety standard so that sensors are not required as a rule. At the discretion of the operator or installer and depending on the spatial conditions and persons using the door, it may be

advisable to use safety sensors even when the system is operated in Low-Energy-Mode, for instance if being used by children or infirm persons. For this purpose, a risk assessment must be carried out by a specialist when the door system is being planned and commissioned. It is at the operator's discretion whether or not a safety device is actually installed. In Full-Energy-Mode the use of additional safety sensors is obligatory.

Preparation of MANET glass door panel

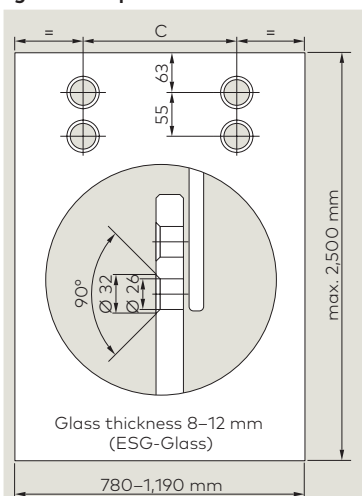

Left door leaf, right door leaf inversely.



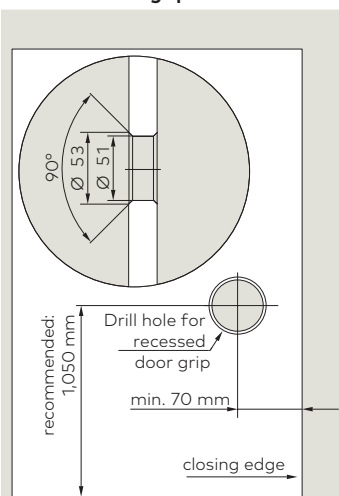

Preparation of optional recessed door grip

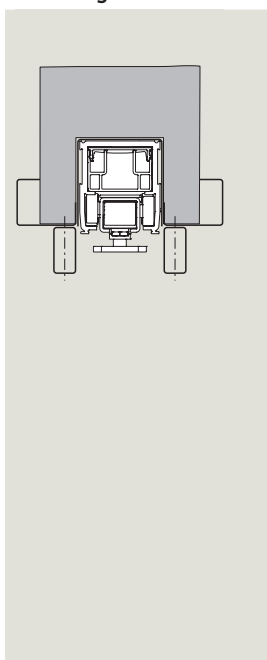

Hints regarding in-wall mounting

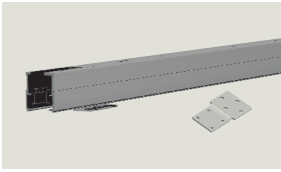
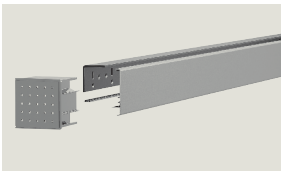
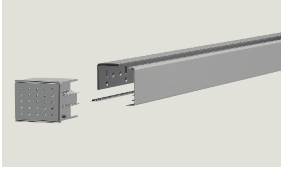
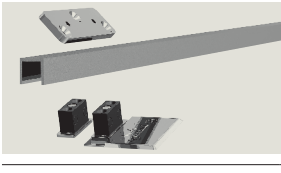
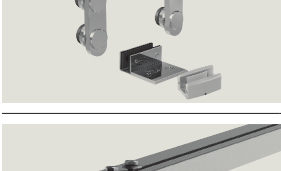

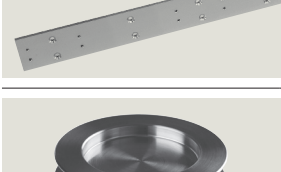

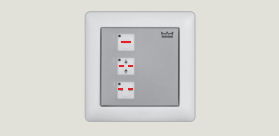

We would recommend covering the door panel connection at the CS 80 MAGNEO operator with profiles so that you will be able to access the operator easily even after the wall has been closed.

dormakaba system components of the modular system	Order No.	Profiles in stock lengths	Order No.
	CS 80 MAGNEO operator incl. set for in-wall mounting	Mill-finish	34002701120
	LV1	E6/C0	34002702120
	LV2	Matt stainless steel design	34002703120
	USA-version with UL-approval		34002801120
	LV1	Mill-finish	34002901120
	LV2	E6/C0	34002902120
	LV3	Matt stainless steel design	34002903120
	LV1	Mill-finish	34005101120
	LV2	E6/C0	34005102120
	Matt stainless steel design	Matt stainless steel design	34005103120
	LV1	Mill-finish	34003006120
	LV2	E6/C0	34003005120
	LV3	Matt stainless steel design	34003007120
	LV1	Mill-finish	34003106120
	LV2	E6/C0	34003105120
	LV3	Matt stainless steel design	34003107120
	LV1	Mill-finish	34003401120
	LV2	E6/C0	34002502120
	LV3	Mill-finish	34003106120
	LV1	E6/C0	34003105120
	LV2	Matt stainless steel design	34003107120
	LV3	Mill-finish	34003106120
	LV1	E6/C0	34003105120
	LV2	Matt stainless steel design	34003107120
	Aluminium profil, mill-finish	Distance profile	34003401120
	LV1	Operator profile	34002502120
	LV2	Accessories: Operator and door panel	Order No.
	LV3	Set for in-wall mounting	84020002
	LV1	Set for on-wall mounting	LV1 84020003
	LV2		LV2 84020004
	LV3		LV3 84020005
	LV1	Set for on-wall mounting (for glass walls)	E6/C0 84020006
	LV2		Matt stainless steel design 84020007
	LV3	Mains cable for	
	LV1	Germany 230 V	84020040
	LV2	UK 230 V	84020041
	LV3	USA 115 V	84020042
	LV1	Italy 230 V	84020043
	LV2	Denmark 230 V	84020044
	LV3	Switzerland 230 V	84020045
	LV1	Australia 230 V	84020046
	LV2	South-Africa 230 V	84020047
	LV3	End caps	
	LV1	Height 62 mm	Mill-finish 84020070
	LV2		E6/C0 84020071
	LV3		Matt stainless steel design 84020072
	LV1	Height 75mm	Mill-finish 84020073
	LV2		E6/C0 84020074
	LV3		Matt stainless steel design 84020075
	LV1		
	LV2		
	LV3		
	LV1		
	LV2		
	LV3		
	LV1		
	LV2		
	LV3		
	LV1		
	LV2		
	LV3		
	LV1		
	LV2		
	LV3		
	LV1		
	LV2		
	LV3		
	LV1		
	LV2		
	LV3		
	LV1		
	LV2		
	LV3		
	LV1		
	LV2		
	LV3		
	LV1		
	LV2		
	LV3		
	LV1		
	LV2		
	LV3		
	LV1		
	LV2		
	LV3		
	LV1		
	LV2		
	LV3		
	LV1		
	LV2		
	LV3		
	LV1		
	LV2		
	LV3		
	LV1		
	LV2		
	LV3		
	LV1		
	LV2		
	LV3		
	LV1		
	LV2		
	LV3		
	LV1		
	LV2		
	LV3		
	LV1		
	LV2		
	LV3		
	LV1		
	LV2		
	LV3		
	LV1		
	LV2		
	LV3		
	LV1		
	LV2		
	LV3		
	LV1		
	LV2		
	LV3		
	LV1		
	LV2		
	LV3		
	LV1		
	LV2		
	LV3		
	LV1		
	LV2		
	LV3		
	LV1		
	LV2		
	LV3		
	LV1		
	LV2		
	LV3		
	LV1		
	LV2		
	LV3		
	LV1		
	LV2		
	LV3		
	LV1		
	LV2		
	LV3		
	LV1		
	LV2		
	LV3		
	LV1		
	LV2		
	LV3		
	LV1		
	LV2		
	LV3		
	LV1		
	LV2		
	LV3		
	LV1		
	LV2		
	LV3		
	LV1		
	LV2		
	LV3		
	LV1		
	LV2		
	LV3		
	LV1		
	LV2		
	LV3		
	LV1		
	LV2		
	LV3		
	LV1		
	LV2		
	LV3		
	LV1		
	LV2		
	LV3		
	LV1		
	LV2		
	LV3		
	LV1		
	LV2		
	LV3		
	LV1		
	LV2		
	LV3		
	LV1		
	LV2		
	LV3		
	LV1		
	LV2		
	LV3		
	LV1		
	LV2		
	LV3		
	LV1		
	LV2		
	LV3		
	LV1		
	LV2		
	LV3		
	LV1		
	LV2		
	LV3		
	LV1		
	LV2		
	LV3		
	LV1		
	LV2		
	LV3		
	LV1		
	LV2		
	LV3		
	LV1		
	LV2		
	LV3		
	LV1		
	LV2		
	LV3		
	LV1		
	LV2		
	LV3		
	LV1		
	LV2		
	LV3		
	LV1		
	LV2		
	LV3		
	LV1		
	LV2		
	LV3		
	LV1		
	LV2		
	LV3		
	LV1		
	LV2		
	LV3		
	LV1		
	LV2		
	LV3		
	LV1		
	LV2		
	LV3		
	LV1		
	LV2		
	LV3		
	LV1		
	LV2		
	LV3		
	LV1		
	LV2		
	LV3		
	LV1		
	LV2		
	LV3		
	LV1		
	LV2		
	LV3		
	LV1		
	LV2		
	LV3		
	LV1		
	LV2		
	LV3 </		





Accessories: Operator and door panel		Order No.
Cover profile set for wall connection		84020090
Guide rail for wooden door panels 1,125 mm		84020112
Floor guide for in-wall mounting		
For wooden door panels		84020123
For glass door panels		80731600099
CS 80 MAGNEO locking device		84020130
Floor guide on metal sheet (frame)		92212001
External floor guide rail (glass)		33438001150
Additional items for double-leaf systems		Order No.
Sync kit		84020131
Mounting angle 4,600 mm	E6/C0	84000067
	Matt stainless steel design	84000068
Cover profile	E6/C0	34005102120
	Matt stainless steel design	34005103120

Pushbuttons and program switches		Order No.
	Pushbutton, flush-mounted design, white System 55	19144701170
	Program switch EPS-S3	16605501150
	Internal program switch (no picture)	16610601175

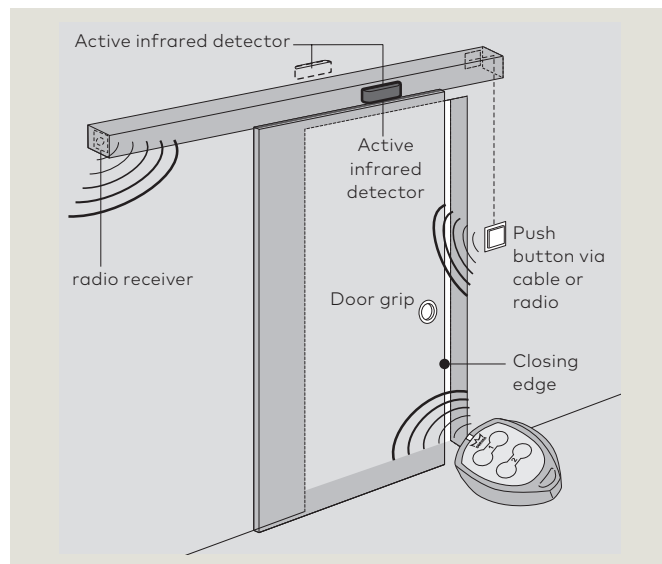
Framework programm for system components		Order No.
	Cover frame single	05157833332 05214233332*
	Cover frame double	05210633332 05214333332*
	Cover frame triple	05210733332 05214433332*
	Cover frame quadruple	05210833332 05214533332*
	Adapter frame for the use of system 55 inserts (i.e. status display, program switches, key pads, emergency button) within system 21 frames.	05210933332

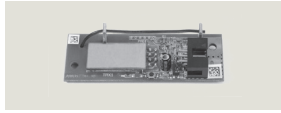
* System 55: For the launch pls. contact your sales person. Please note that system 55 covers can not combined with the old system 21 switch inserts.



Comfort switch with BRC radio technology		Order No.
	BRC-R receiver	29302002
	Additional set of radio switches (always required for radio systems, no picture)	84020081
	BRC-H handheld transmitter	29304001
	BRC-W large-surface pushbutton	29301005

Active infrared detectors		Order No.
	Combination sensor IXIO-DT1	
	black	86800001
	silver	86800002
	Combination sensor IXIO-DT3	
	black	86800004
	silver	86800005
	Safety curtain IXIO-ST	
	black	86800010
	silver	86800011
	white	86800012

Four steps to create your door system.

Then everything will
work automatically.

1. Measuring

Measure the passage and the required dimensions on site. Please consider the CS 80 MAGNEO planning aid leaflet to determine all important dimensions. If you are interested in this leaflet, please contact your dormakaba specialist dealer or visit us on the internet: www.dormakaba.com.

2. Planning

Please determine the size of the planned door panel/door, the required length version LV and the position of the CS 80 MAGNEO. The information on pages 8 to 11 in this brochure will help you.

3. Select system components

The CS 80 MAGNEO is a modular system. The table on pages 12-13 indicates the required system components for all ways of mounting. Please enter the article numbers on the form on the back of this paper.

4. Order system components and door panels

Place an order for the desired CS 80 MAGNEO components with your authorised dormakaba dealer. Please contact the glazier or joiner to order the suitable door panel. The technical specifications for the door panel on pages 10 and 11 will help you during the placement of your order.

Planning guide

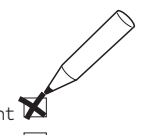

1. What kind of mains connection would you prefer?

- Fixed 230 V connection Standard equipment
- 230 V mains cable

2. How would you like to open and close the door?

- Automatic activation (opening) as soon as the door panel is pushed by hand (Push&Go)..... Standard equipment
- Recessed door grip for door panel (recommended with Push&Go Function).....
- Automatic closing after a certain time (adjustable)..... Standard equipment
- Manual opening and closing (in case of power failure)..... Standard equipment
- Automatic activation (opening) via pushbutton
 - a. Connected via cable.....
 - b. Connected via radio.....
- Automatic activation (opening) via motion detector.....
- Automatic opening via hand held radio control.....

3. How would you like to adjust the function programs (Off, Automatic, Permanent Open)?

- Adjustment of function programs via internal program switch (located at end cap, only with on-wall mounting).....
- Adjustment of "Permanent Open Function" in manual mode..... Standard equipment

4. Do you require safety or presence sensors to safeguard the closing edges?

The limited driving speeds and the low contact force provide a high safety standard when the system is operated in the standard "Low-Energy-Mode" (system status of CS 80 MAGNEO on delivery). A risk assessment must be carried out during planning and commissioning to determine whether the use of additional sensors is required. The installation of additional sensors is optional and lies in the discretion of the facility operator. If the CS 80 MAGNEO is operated in extended "Full-Energy-Mode", the closing edges have to be additionally protected. The respective safety equipment has to be installed by a specialist for automatic door systems.

- Touch sensitive closing edge safety according to EN 16005, DIN 18650, ANSI and BSI..... Standard equipment
- Additional sensors (has to be installed by a specialist).....

5. What is the structural situation at the installation area?

- Please measure the passage width DB..... Passage width DB = mm
- Please measure the passage height DH..... Passage height DH = mm
- Are there any doorframes or baseboards?
- If so, please sign in the AW-dimension..... AW = mm

6. Please define the distance between doorway and operator.

- a. at **on-wall mountings** up to lower edge of the operator A^U.....distance A^U = mm
- b. at **in-wall mountings** up to top edge of the operator A^O.....distance A^O (min. 72 mm) = mm

7. What is the size of the door panel?

a. You don't know the dimensions of the door panel yet?

Please determine the door panel size in three steps and sign in the results in the gaps below.

1. You can freely choose the door panel projection A^B between 40 and 65 mm.
2. Calculate the door panel width **B = DB + 2 x A^B or DB / 2 + A^B** for double-leaf systems.
3. Calculate the height of the door panel **H** for:

at a	On-wall mounting	In-wall mounting
Wooden door	H = DH + A ^U - 3 mm	H = DH + A ^O - 75 mm
Glass door with glass clamping rail	H = DH + A ^U - 10 mm	H = DH + A ^O - 81 mm
Glass door with MANET single point fixings	H = DH + A ^U - 12 mm	

b. You already know the dimensions of the door panel?

1. Please sign in the door panel height **H** and the door panel width **B** in the gaps below.
2. Calculate the door panel projection **A^B = (B-DB)/2 or A^B = B -(DB/2)** for double-leaf systems.

Door width **B** (min. 780 mm, max. 1,190 mm) ... = mm
 Door height **H** (max. 2,500 mm) = mm
 Door panel projection **A^B** (max. 65 mm) = mm

8. Which design fits to your furnishings (on-wall mounting)?

- a. Individual request on surface area (extra charge).....
- b. dormakaba E6/CO suitable for all products of dormakaba.....
- c. Matt stainless steel design suitable special for all products of the dormakaba interior glass products

9. Locking device

notes

