

SST FLEX SST FLEX Green

Automatic break- out sliding doors



SST FLEX and SST FLEX Green

Slide open to normal width, break-out to full width.

Automatic sliding doors with break-out from dormakaba fit into different structural openings, satisfy a variety of demands and can be adapted to suit individual requirements.



The classic door solution for emergency exits and escape routes

With SST automatic sliding doors with break-out, not only the door panels but also the side screens are pivot-mounted to swing out when needed - without the need to disengage any locks. This doubles the passage width of the doorway particularly in cases of emergency.

The break-out function for the sliding panels and side screens is also approved in most countries as a viable solution for emergency exits. The approved escape route function is not available in the operating states "Off" or "Locked".

Proven drive technology

Powerful dormakaba ES PROLINE door operators are characterised by their fast, smooth motion cycles, minimal noise emission and exceptional user friendliness. ES PROLINE operators, with which the door sets presented here are equipped, have that extra capacity reserve which means that they continue to perform efficiently even when put under strain.

Exceptional economy

The variability of the dimensions available with SST FLEX automatic sliding doors means that they can be specified for maximum economy. Yet every door set is designed and made to measure and then supplied ready for installation. And dormakaba will also carry out the installation and commissioning work if requested.

Convenient and safe

The control units with their adjustable parameters and self-learn capability offer a full range of functionality. They are also utterly reliable and, together with the closing force monitoring, provide for maximum operational safety.

Features and benefits

- Excellent scope of supply
- Easily adapted to individual requirements
- Emergency exit and escape route doors with break-out panels and side screens
- Highly economical and reliable thanks to proven standard components
- Wide range of adjustable parameters
- Extensive provision of standard connections
- Supplied ready for installation – mounting and commissioning on request
- Profile systems: SST FLEX or SST FLEX Green with improved thermal separation

SST Flex
Slim profile system

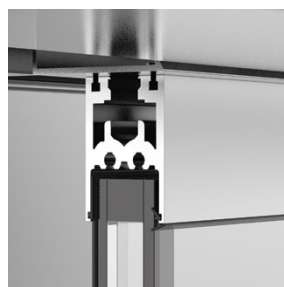

SST Flex Green
Slim profile system with improved thermal separation

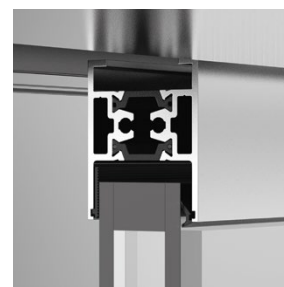

Quality-assured manufacture

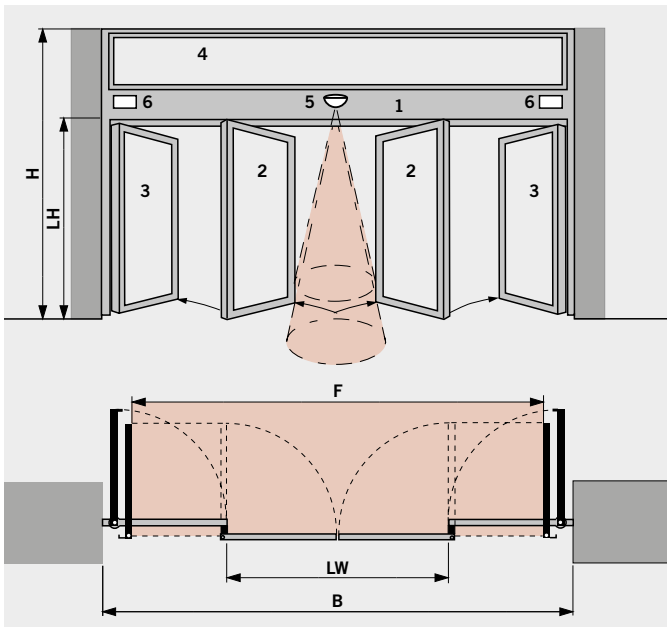

- 01** Self-supporting header, operator with integrated control unit
- 02** Break-outdoor panels with toughened (TSG) or laminated (LSG) safety glass
- 03** Side screens with break-out function
- 04** Fanlight or panel cover
- 05** Activators like motion detectors or sensors
- 06** Safeguarding of secondary closing edges to DIN 18650 and EN 16005

H	System height
LH	Clear passage height
B	System width
F	Escape route width
LW	Clear passage width

In the event of a panic, the moving leaf and side panels can be swivelled

Pressure applied against the door panels and side screens of automatic break-out sliding door systems suffices to activate the break-out function, leaving the way out free. Fast escape from buildings equipped with this automatic break-out sliding door system is thus ensured, even in a crush. Once broken out, the pivoted door panels and side screens remain in their position, however, they can easily be moved aside by hand. When closed, dormakaba SST automatic break-out sliding door systems effectively protect the interior against heat loss and draughts thanks to their especially developed frame profiles with integrated high-performance seals. At the same time, the Softline cross sections and the minimum clearances between the door panels and the side screens provide maximum safety in the event of user contact with the door panels. Effective finger guard thanks to specially shaped pivot profiles at the break-out side screens.

SST FLEX

Slim profile system without thermal optimization

With the FLEX fine-frame system developed by dormakaba, these automatic sliding doors with break-out offer all the aesthetic elegance of a full-glass construction. The FLEX profile system provides maximum flexibility as it can be combined with toughened safety glass or double glazing. Slender though they are, the profiles nevertheless offer optimum

sealing performance and outstanding glass edge protection. Automatic sliding doors with break-out are the ideal solution wherever ensuring safety in emergency escape routes is the main priority. At the same time, they also offer maximum light penetration, visibility and architectural compatibility.

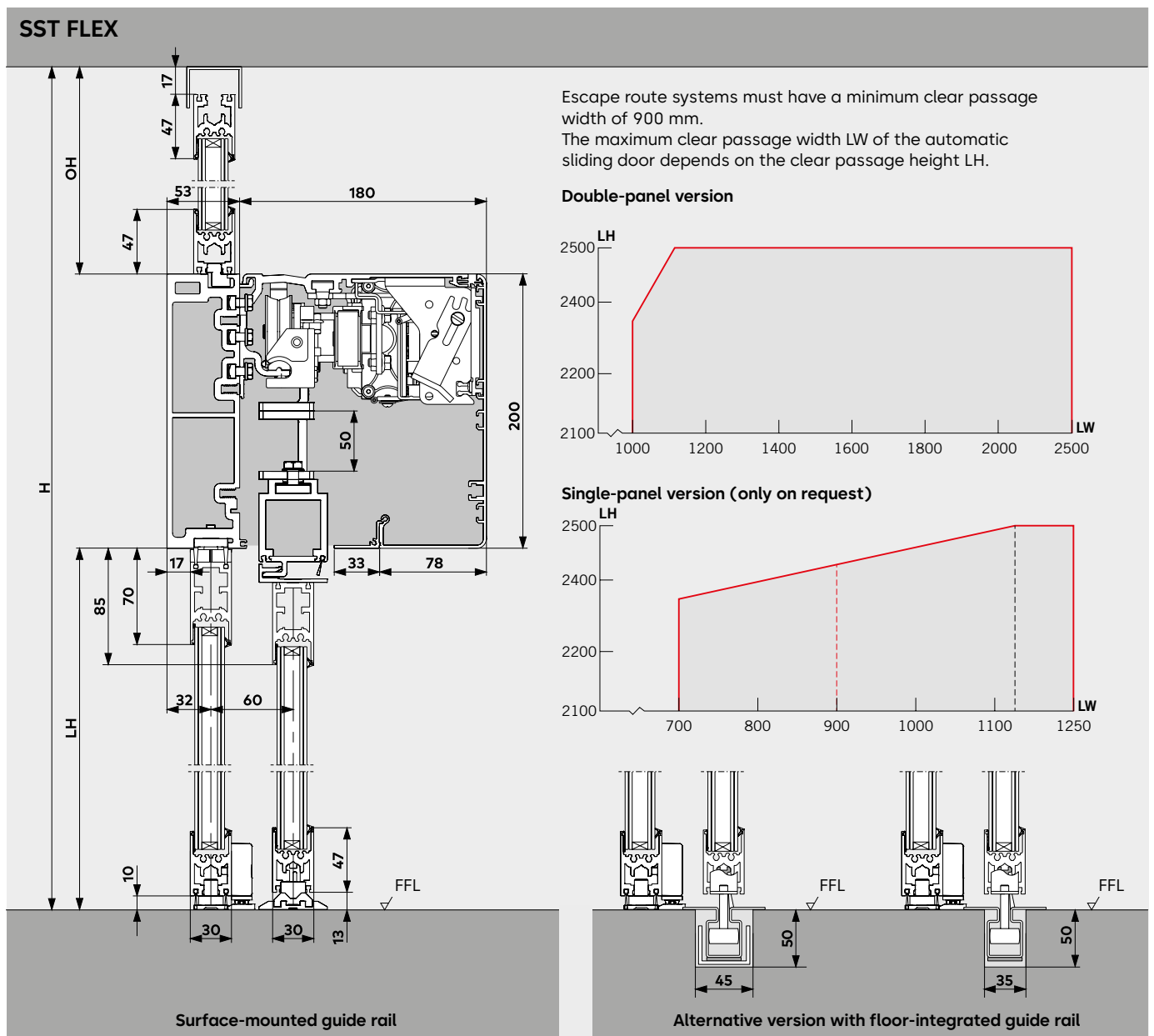

Double-panel version with surface-mounted guide rail

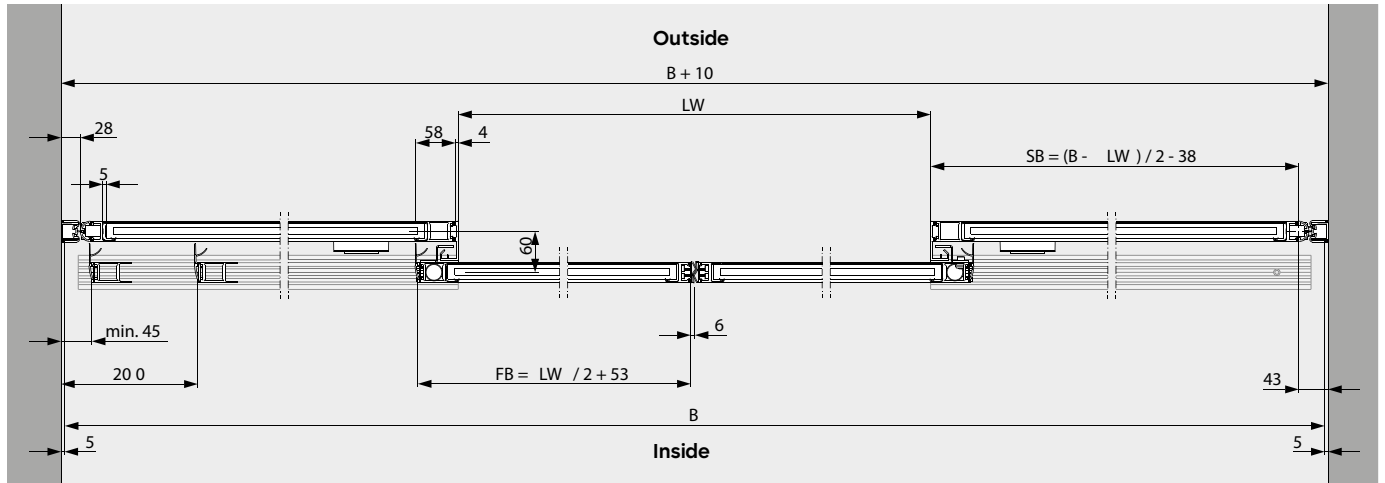

Double-panel version with floor-integrated guide rail

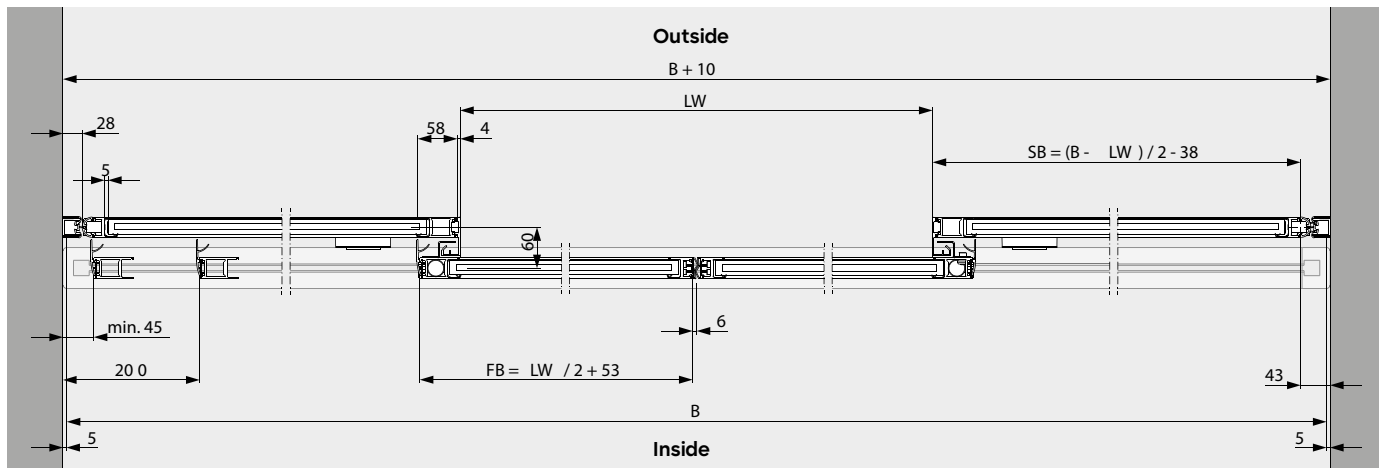

Dimensions and versions

Sliding panel and side screen profiles as FLEX- oder FLEX Green	●
Fanlight	○
Door panels with break-out function	●
Side screens with break-out function	●
Approved for application in escape routes	●
Clear passage width (LW)	1000 – 2500 mm
System width (B)	2520 – 5520 mm
Max. door-panel weight	2 x 110 kg
Operator cross section W x H (with square-edged cover)	233 x 200 mm
Clear passage height (LH)	2100 – 2500 mm
Safety clearance at secondary closing edges	○
Software for monitoring of secondary closing edges	○

● Standard ○ Option

Calculating the door dimensions

Profil	FLEX
Including safety clearance	$B1 = LW \times 2 + 520$ $LW = (B1 - 520) / 2$
Without safety clearance	$B2 = LW \times 2 + 210$ $LW = (B2 - 210) / 2$
Single-panel version (only on request)	

B	System width
B1	System with incl. safety clearance
B2	System with without safety clearance
SB	Side screen width
FB	Door panel width
F	Escape route width
LW	Clear passage width
H	System height
OH	Height of fanlight
LH	Clear passage height
FFL	Finished Floor Level

SST FLEX Green

Slim profile system with thermal optimization

Break-out sliding door with the FLEX Green profile are energy-saving doors specially designed for external building closures. The profiles with improved thermal separation result in very good insulation values. Even the most unfavourable sizes still meet the strict requirements of the current Building Energy Act (GEG).

The heat transfer coefficients UD are documented by test certificates. The sustainability of the door is certified by an Environmental Product Declaration (EPD). Thanks to the slim profile face widths, this door type can be combined very well with other door systems from the FLEX family.

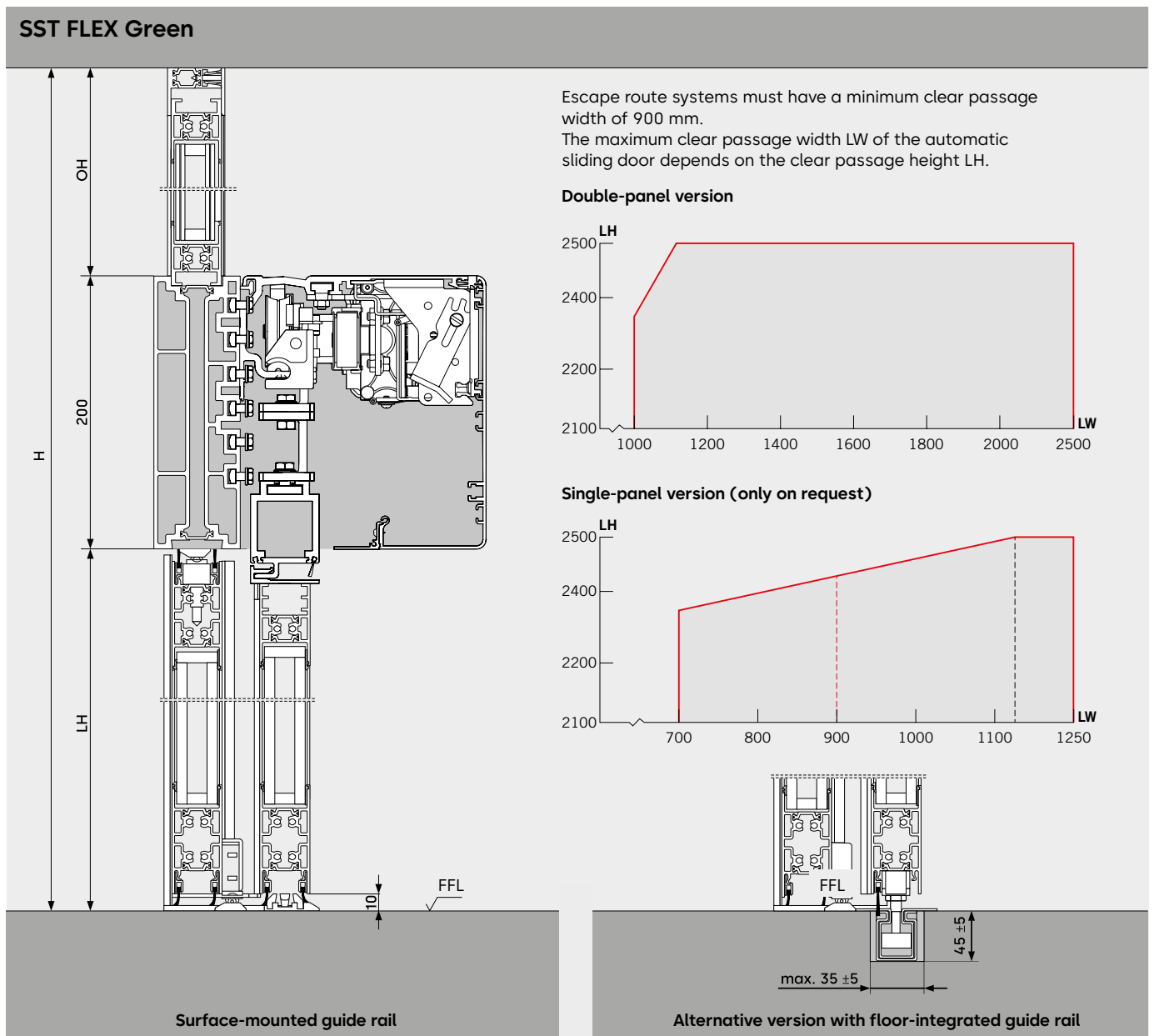

Double-panel version with surface-mounted guide rail

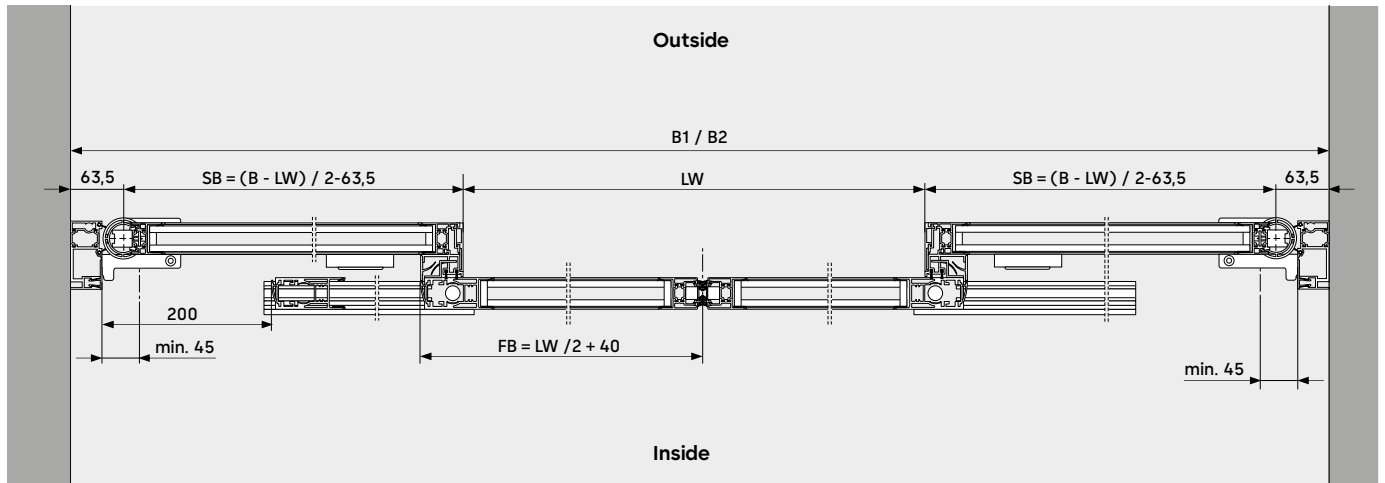

Double-panel version with floor-integrated guide rail

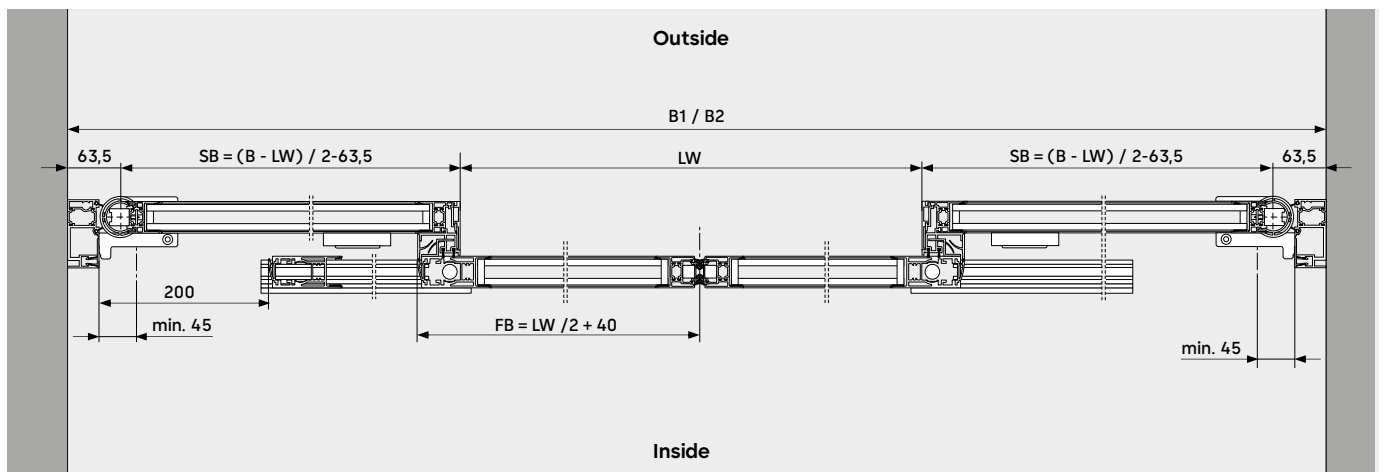

Dimensions and versions

Sliding panel and side screen profiles as FLEX- oder FLEX Green	●
Fanlight	○
Door panels with break-out function	●
Side screens with break-out function	●
Approved for application in escape routes	●
Clear passage width (LW)	1000 – 2500 mm
System width (B)	2520 – 5520 mm
Max. door-panel weight	2 x 110 kg
Operator cross section W x H (with square-edged cover)	233 x 200 mm
Clear passage height (LH)	2100 – 2500 mm
Safety clearance at secondary closing edges	○
Software for monitoring of secondary closing edges	○

● Standard ○ Option

Calculating the door dimensions

Profil	FLEX Green
Including safety clearance	$B1 = LW \times 2 + 575$ $LW = (B1 - 575) / 2$
Without safety clearance	$B2 = LW \times 2 + 265$ $LW = (B2 - 265) / 2$
Single-panel version (only on request)	

B	System width
B1	System with incl. safety clearance
B2	System with without safety clearance
SB	Side screen width
FB	Door panel width
F	Escape route width
LW	Clear passage width
H	System height
OH	Height of fanlight
LH	Clear passage height
FFL	Finished Floor Level

Drive and control unit

Functions and features

Control module	ES 250 PRO
Function programs	<ul style="list-style-type: none"> – Off ● – Automatic ● – Permanent open ● – Partial open ● – Exit ●
Automatic reversing	●
Connection for securing the passageway (on both sides)	●
Tested in accordance with EN 16005/DIN 18650	●
Securing main and secondary closing edge(s) according to EN 16005/DIN 18650	●
Basic parameters set using integrated display and buttons	●
Parameterisation via Operator Service Interface (OSI)	●
Door Pilot interface (Bluetooth)	○
Automatic opening/closing in the event of a power failure (if a battery set is used)	●/●
Emergency battery operation (if a battery set is used)	●
24 V DC output for external appliances	●
Readable fault memory with fault codes	●
CAN interface for connecting a program switch	●
CAN interface for connecting additional CAN-bus components	●
Multiports for connecting accessory components	4
Functions*	
Pharmacy function	●
Door status signal contacts	●
Panic closing (observe regional regulations!)	●
Door bell contact	●
Airlock control	●
Synchronous operation	●
Safety deactivation	●
Night/bank function	●
Emergency open	–
Emergency stop	●
Configurable partial opening distance	●
Slide and Go	●
Close/open on malfunction	●
Fire service switch function	●

*The functions can be implemented by the master controller or by the 4 I/O modules. For further information, see brochure ES-PROLINE

Settings	
Opening speed (adjustable in increments)	10 – 70 cm/s
Closing speed (adjustable in increments)	10 – 70 cm/s
Low speed OPEN	0 – 9 cm/s
Low speed CLOSE	3 – 9 cm/s
Hold-open time, night/bank hold-open time	0 – 180 s
Night/bank opening delay	0 – 10 s
Partial opening	25 – 300 cm
Low-speed travel OPEN/CLOSE	0 – 30 cm

Auxiliary equipment

Electromechanical combined locking device	○
Electrical manual lock release (only with rechargeable battery pack)	○
Battery set	○
Emergency power supply UPS (external)	○
Module for connection to LON/LAN building control systems	○
Potential-free relay contact	○

Safety and activation (SiAK) expansion module*

For connecting conventional (not CAN-bus-capable) safety and activation sensors ○

Program switch (MS) expansion module*

For connecting conventional (not CAN-bus-capable) program switches ○

*For further information, see brochure ES-PROLINE

Standardisation and testing

Compliant with the Low Voltage Directive and the EMC Directive	●
Monitoring of secondary closing edges verified to fulfil German standard DIN 18650 and EN 16005.	●
Manufactured to ISO 9001	●
Environmental product declaration according to ISO 14025; declaration holder: Institut Bauen und Umwelt e.V.	●

● Standard ○ Option – Not extendable

Connections with CAN-bus technology

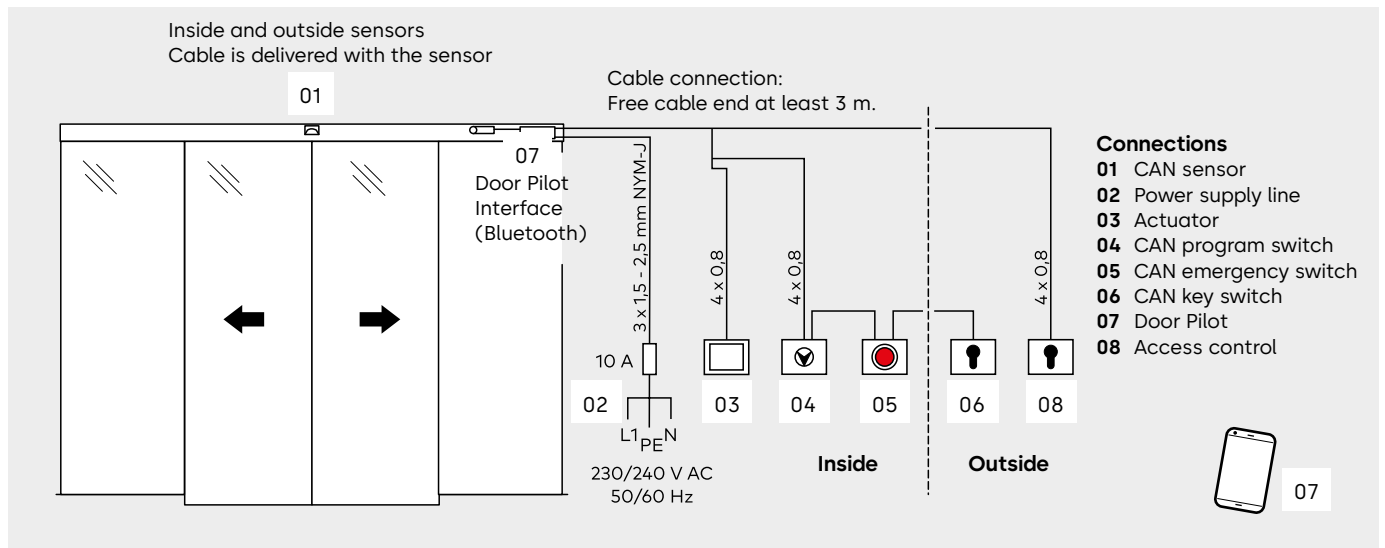

Conventional technology connections

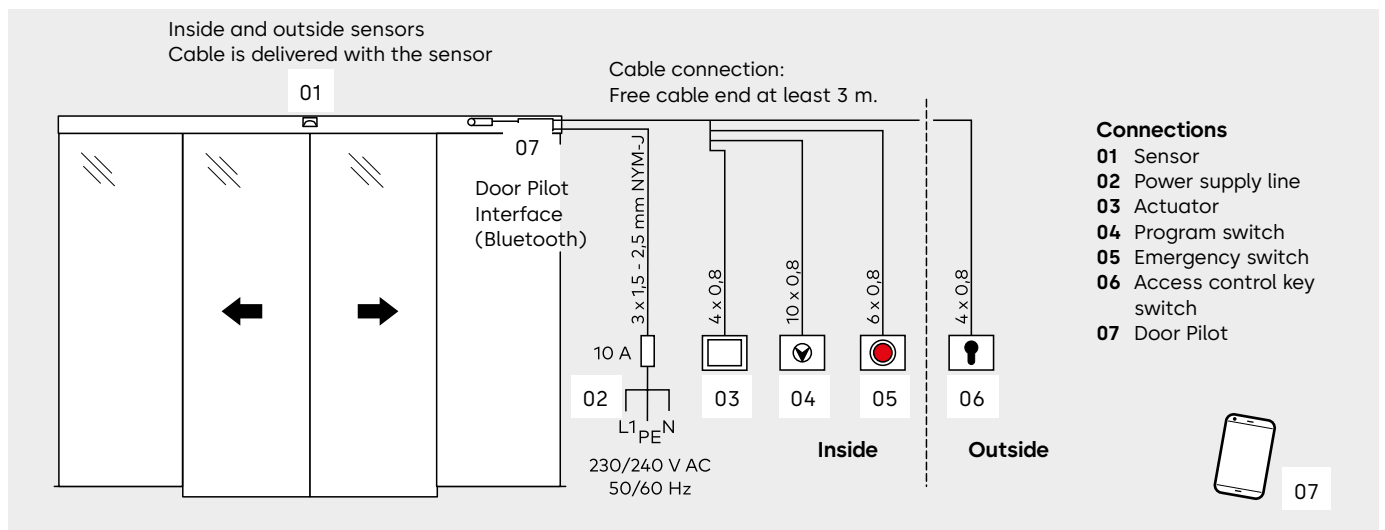

Door Pilot App

The dormakaba Door Pilot app allows automatic doors to be easily controlled from a smartphone. Operators from the ES PROLINE series can be equipped with the Door Pilot interface as an option. The app is available in iOS and Android versions and can be obtained from the respective app store. For further information, see brochure ES-PROLINE

Power supply

Supply voltage	230 V, 50/60 Hz
Power consumption	130 W
On-site line fuse	10 A
Degree of protection	IP 20
Power supply for peripheral equipment under network conditions	24 V DC/2A
Power supply for peripheral equipment in the event of a power failure (battery operation)	Optional 21-27 V DC/2A
Temperature range	-20 - + 60 °C
Permissible air humidity (relative) (non-condensing)	max. 93 %

Wide range of accessories from dormakaba

Program switches

When combined with a program switch from the dormakaba accessories range, the automatic door system can satisfy all kinds of individual operating requirements and is easy to use. The program switches have been designed in various versions and for a wide range of requirements.

The options range from mechanical to fully electronic versions locked by your choice of profile cylinders, round cylinders or fully electronic coding.

- Up to 5 different functions: Off, automatic, exit only, partially open, permanent open
- Electronic program switches in System 55 design for the most discerning aesthetic demands

For sliding door operators without escape route and emergency exit requirements

Article no.

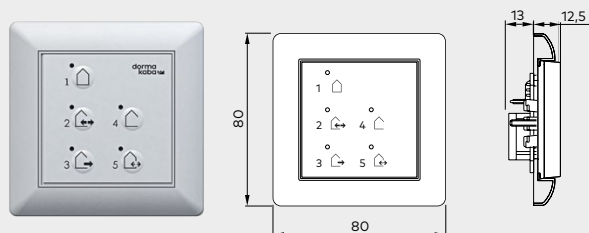

EPS fully electronic program switch

System 55 design, 5 positions, lockable using coding or additional TL-ST S55 key switch, membrane keypad, concealed, 80 x 80 mm

EPS	White	16556901150
EPS CAN	White	16712501150
Box for surface mounting		5158533332
EPS CAN (44 x 50 mm)		16712401150

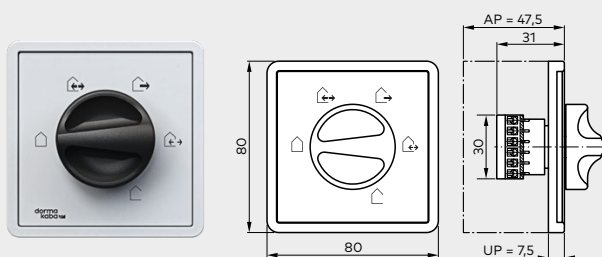

PG-S1 program switch

5 positions, aluminium, concealed, 80 x 80 x 40 mm

PG-S1	White, Gira S-Color	19135401150
Box for surface mounting		5080531332

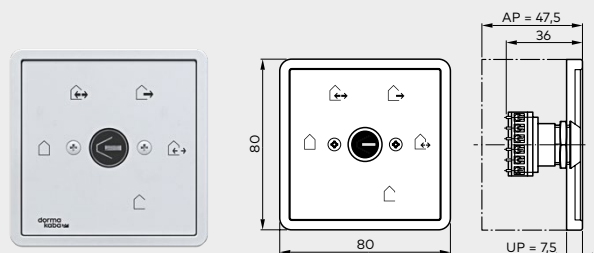

PG-S2 program switch

5 positions, lockable, aluminium, concealed, 80 x 80 x 40 mm

PG-S2	weiss, Gira S-Color	19135602150
Box for surface mounting		5080531332

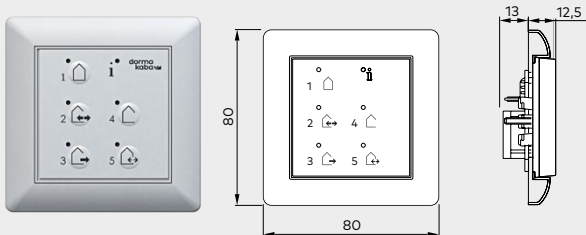
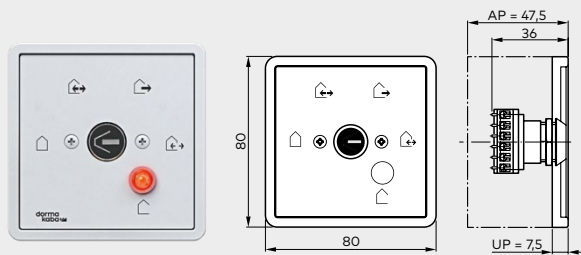

For sliding door operators in escape routes and emergency exits

Article no.

PG-FST1 program switch

5 positions, lockable, aluminium, concealed, 80 x 80 x 40 mm

PG-FST1	White, Gira S-Color	19135603150
Box for surface mounting		5080531332

EPS-FST fully electronic program switch

System 55 design, 5 positions, lockable using coding or additional TL-ST S55 key switch, membrane keypad, concealed, 80 x 80 mm

EPS-FST	White	16556801150
EPS CAN	White	16712501150
Box for surface mounting		5080531332

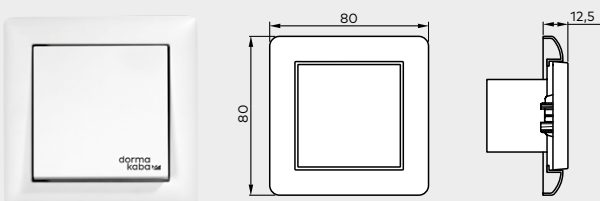
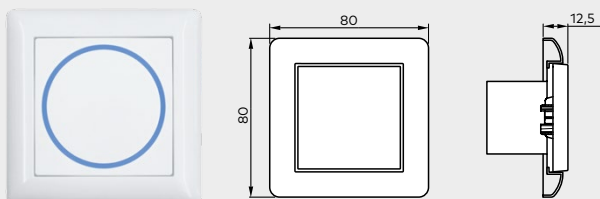

Activation switches

Article no.

CleanSwitch

contactless radar push-button, System 55, flush-mounted, detection zone adjustable 10 - 50 cm, dimensions: 80 x 80 x 40 mm, switch insert 55 x 55 mm, colour: white

CleanSwitch	neutral	16737401170
	wheelchair	16737501170
	door open	16737601170

Manual release switch

Single-pole change-over contact, single frame, concealed, System 55

Manual release switch	White	19144701170
-----------------------	-------	-------------



Key switch

Article no.

KT 3-1

1 NO contact with Europrofile half-cylinder in line with DIN 18252, half 30–32.5 mm, length 40.5–43.5 mm, locking cam position left (90°) (interchangeable with master-key system half-cylinder), key can only be removed in neutral position, aluminium, metal, 75 x 75 x 60 mm

KT 3-1 UP	Concealed	05054531332
KT 3-1 AP	Surface-mounted	05054631332

KT 8

Labelled "Open"/"Closed", 2 NO contacts with Europrofile half-cylinder in line with DIN 18252, half 30–32.5 mm, length 40.5–43.5 mm, locking cam position left (90°) (interchangeable with master-key system half-cylinder), key can only be removed in neutral position, aluminium, metal, 75 x 75 x 60 mm

KT 8 UP	Concealed	05054831332
KT 8 AP	Surface-mounted	05054931332

TL-ST S55

Push button with single-pole changeover contact for on-site Europrofile half-cylinder in line with DIN 18252, half 30–32.5 mm, length 40.5–43.5 mm, locking cam position left (90°), with cover for System 55, not suitable for surface-mounted boxes, without Europrofile half-cylinder, **without frame**.

TL-ST S55 W	White	56330710
TL-ST S55 S	Silver	56330701
TL-ST S55 A	Anthracite	56330715

KT 3-2

1 NO contact with Europrofile half-cylinder, interchangeable with master-key system half cylinder, key can only be removed in neutral position, cover panel for replacement, labelled "Open"/"Closed", aluminium, concealed: 125 x 100 mm, surface-mounted: 70 x 90 mm

KT 3-2	05054731332
--------	-------------

Key switch CAN

Switch with single-pole changeover contact, with Europrofile half-cylinder in line with DIN 18252, half 30–32.5 mm, length 40.5–43.5 mm, locking cam position left (90°) (interchangeable with master-key system half-cylinder), with cover for System 55, not suitable for surface-mounted boxes, without frame.

Schlüsseltaster CAN	16715801150
---------------------	-------------

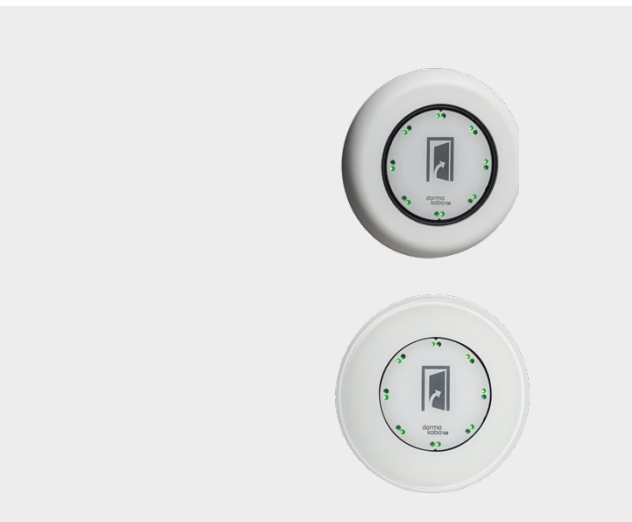

LED touch key

Article no.

LED touch key

Manual actuator with plastic frame in white, similar to RAL 9016 and traffic grey similar to RAL 7043

LED touch key	16672601170
---------------	-------------

LED hygienic touch key

Manual actuator, tempered glass encapsulated, glass button surface, hygienic version in line with EN 1672-1/2

LED touch key	16672901170
---------------	-------------

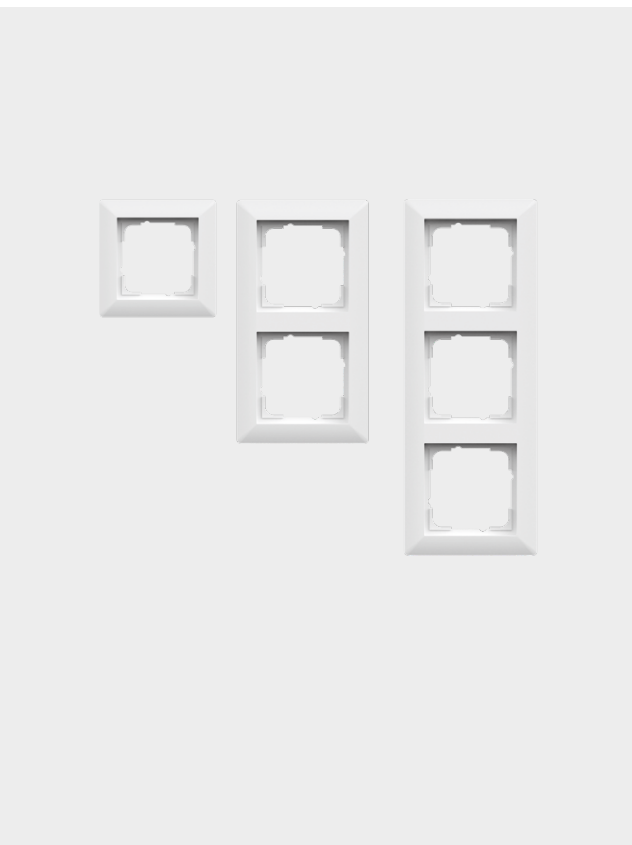

Emergency activation buttons

Article no.

Emergency switch CAN

CAN-bus emergency activation button, red knob (emergency activation button off) or green knob (emergency open), System 55, without frame.

Emergency switch CAN, red	16718501150
Emergency switch CAN, green	16718502150

TL-N S55 conventional

The area around the emergency button is brightly illuminated and has a visual display of the locking status, an acoustic and visual alarm siren, is tamper-protected under glass, without frame, one NO contact and one NC contact, concealed, 80 x 80 mm, System 55

TL-N S55	56330500
----------	----------

Conventional emergency switch

Emergency activation button (Emergency Off function with red knob and Emergency Open function with green knob) with yellow central plate

NAT 1	One NO contact and one NC contact, white frame, concealed, 80 x 80 mm, System 55	90400025
NAT 2	Emergency Open version with green knob, white frame, concealed, 80 x 80 mm, System 55	90400035
NAT 4	One NO and one NC contact, surface-mounted 68 x 68 mm Concealed	05027031332

Cover frame for buttons and switches

Article no.

Standard System 55

FR-S55 1	Single frame, white, 80.7 x 80.7	56391110
FR-S55 2	Double frame, white, 151.8 x 80.7	56391210
FR-S55 3	Triple frame, white, 223.3 x 80.7	56391310

E2 System 55 (not shown)

FR-E2W 1	Single frame, E2 55, white, 80.8 x 80.8	56392110
FR-E2W 2	Double frame, E2 55, white, 151.9 x 80.8	56392210
FR-E2W 3	Triple frame, E2 55, white, 223.4 x 80.8	56392310
FR-E2S 1	Single frame, E2 55, silver, 80.8 x 80.8	56392101
FR-E2S 2	Double frame, E2 55, silver, 151.9 x 80.8	56392201
FR-E2S 3	Triple frame, E2 55, silver, 223.4 x 80.8	56392301
FR-E2A 1	Single frame, E2 55, anthracite, 80.8 x 80.8	56392115
FR-E2A 2	Double frame, E2 55, anthracite, 151.9 x 80.8	56392215
FR-E2A 3	Triple frame, E2 55, anthracite, 223.4 x 80.8	56392315

Active infrared sensor and combined sensors

Article no.



Combined sensor IXIO-DT1

Combined sensor featuring radar detector with direction recognition and safety curtain for non-escape route systems

IXIO-DT1	Black	86800001
	Silver	86800002
	White	86800003

Combined sensor IXIO-DT3

Combined sensor featuring self-monitored radar detector with direction recognition and safety curtain for escape route systems

IXIO-DT3	Black	86800004
	Silver	86800005
	White	86800006

Safety curtain IXIO-ST

Safety curtain (tested) IXIO-ST for monitoring closing edges

IXIO-ST	Black	86800010
	Silver	86800011
	White	86800012



Combined sensor IXIO-D CAN

Combined sensor featuring radar detector with direction recognition and safety curtain for escape route systems and non-escape route systems (CAN-bus technology)

IXIO-D CAN	Black	86800053
	Silver	86800057
	White	86800056

Safety curtain IXIO-S CAN

Safety curtain (tested) IXIO-S CAN for monitoring closing edges (CAN-bus technology)

IXIO-S CAN	Black	86800055
	Silver	86800059
	White	86800058

Integrated combined sensor IXIO-D CAN

Combined sensor (without cover) featuring self-monitored radar detector with direction recognition and safety curtain for escape route and non-escape route systems for integration into the sensor casing.

Integrated IXIO-D CAN	86800050
-----------------------	----------

Integrated safety curtain IXIO-S CAN

IXIO-S CAN safety curtain (tested, without cover) for monitoring closing edges (CAN-bus technology), for integration into the sensor casing.

Integrated IXIO-S CAN	86800052
-----------------------	----------

Accessories for active infrared sensor and combined sensors

Article no.

Ceiling installation set

Ceiling installation system for IXIO-DT and IXIO-S

Ceiling installation set	Black	86800019
	White	86800020



Rain protection cover

Rain protection cover for IXIO-DT and IXIO-ST

Rain protection cover	Black	86800021
-----------------------	-------	----------



Fixing bracket

Fixing bracket for IXIO-DT and IXIO-ST

Fixing bracket	Black	86800016
----------------	-------	----------



Our Sustainability Commitment

We are committed to foster a sustainable development along our entire value chain in line with our economic, environmental and social responsibilities toward current and future generations. Sustainability at product level is an important, future-oriented approach in the field of construction. In order to give quantified disclosures of a product's environmental impact through its entire life cycle, dormakaba provides Environmental Product Declarations (EPD), based on holistic life cycle assessments.

www.dormakaba.com/sustainability



Our offering

Access Automation Solutions

Entrance Automation
Entrance Security



Access Control Solutions

Electronic Access & Data
Escape and Rescue Systems
Lodging Systems



Access Hardware Solutions

Door Closers
Architectural Hardware
Mechanical Key Systems



Services

Technical Support
Installation and commissioning
Maintenance and Repair



WN 05212851532, EN, 02/2024
Subject to change without notice



dormakaba.com

dormakaba
International Holding AG
Hofwissenstrasse 24
CH-8153 Rümlang
T +41 44 818 90 11
info@dormakaba.com
dormakaba.com