

WN 059156-45532, 1.1/16

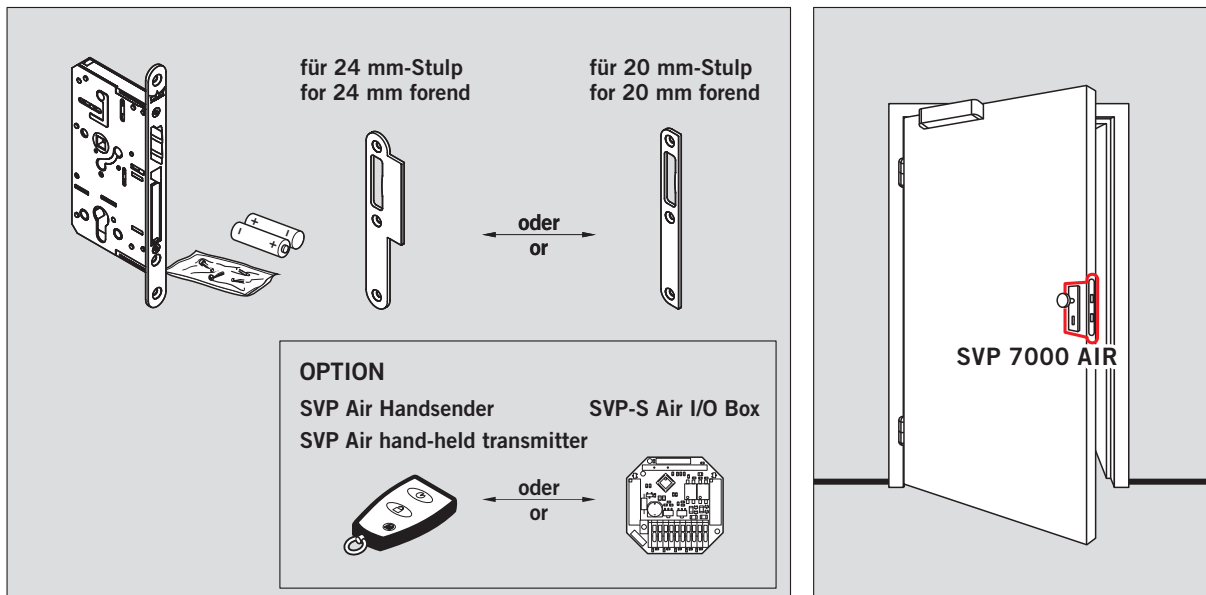

	dormakaba Deutschland GmbH Postfach 4009 - 58 247 Ennepetal															
	1309-CPR-0346												16			
SVP 7000 AIR	DIN EN 179: 2008	3	7	6	B	1	4	5	2	A	B/D					
DOP_0140																

	dormakaba Deutschland GmbH Postfach 4009 - 58 247 Ennepetal															
	1309-CPR-0348												16			
SVP 7000 AIR	EN 14846: 2008	3	R	5	C/D	0	J	3	0	3						
DOP_0140																

	dormakaba Deutschland GmbH Postfach 4009 - 58 247 Ennepetal															
	1309-CPR-0347												16			
SVP 7000 AIR	EN 1125: 2008	3	7	6	B	1	4	2	2	A	B					
DOP_0140																

Technische Daten



Betriebstemperatur: -10°C bis +55°C
 Lagertemperatur: -20°C bis +60°C
 Rel. Luftfeuchtigkeit: von 30% bis 95%;
 keine Betauung
 Betriebsspannung: 3V DC
 Batterien: 2x Energizer L92 Lithium
 Batterie AAA, 1,5 Volt
 Frequenz: 868,3 Mhz

Technical data



Operating temperature: -10°C to +55°C
 Storage temperature: -20°C to +60°C
 Relative humidity: min. 30% max. 95%;
 no condensation
 Operating voltage: 3V DC
 Batteries: 2x Energizer L92 Lithium
 Battery AAA, 1.5 Volt
 Frequency: 868.3 Mhz

Demontage, Recycling und Entsorgung

Die Demontage erfolgt in umgekehrter Reihenfolge der Montageanleitung und muss durch sachkundiges Personal erfolgen.

Schalten Sie das Produkt spannungsfrei, bevor Sie es demontieren.



Entsorgen Sie das Produkt umweltgerecht. Elektrotechnische Teile und Batterien dürfen nicht über den Hausmüll entsorgt werden. Entsorgen Sie diese in den dafür eingerichteten Annahme- und Sammelstellen.

Beachten Sie die für Sie geltenden nationalen gesetzlichen Vorschriften.

Disassembly, recycling and disposal

The disassembly of the door drive is carried out in the reverse order of the installation instructions and is to be performed by skilled personnel.

De-energize the door system before the disassembly.



Dispose of the product in an environmentally-friendly manner. Electronic parts and batteries may not be disposed of in the general trash. Take them to a battery collection point for disposal.

Always comply with the applicable national legal provisions.

SVP 7000 Air

Montage- und Inbetriebnahmeanleitung / Mounting and commissioning instructions

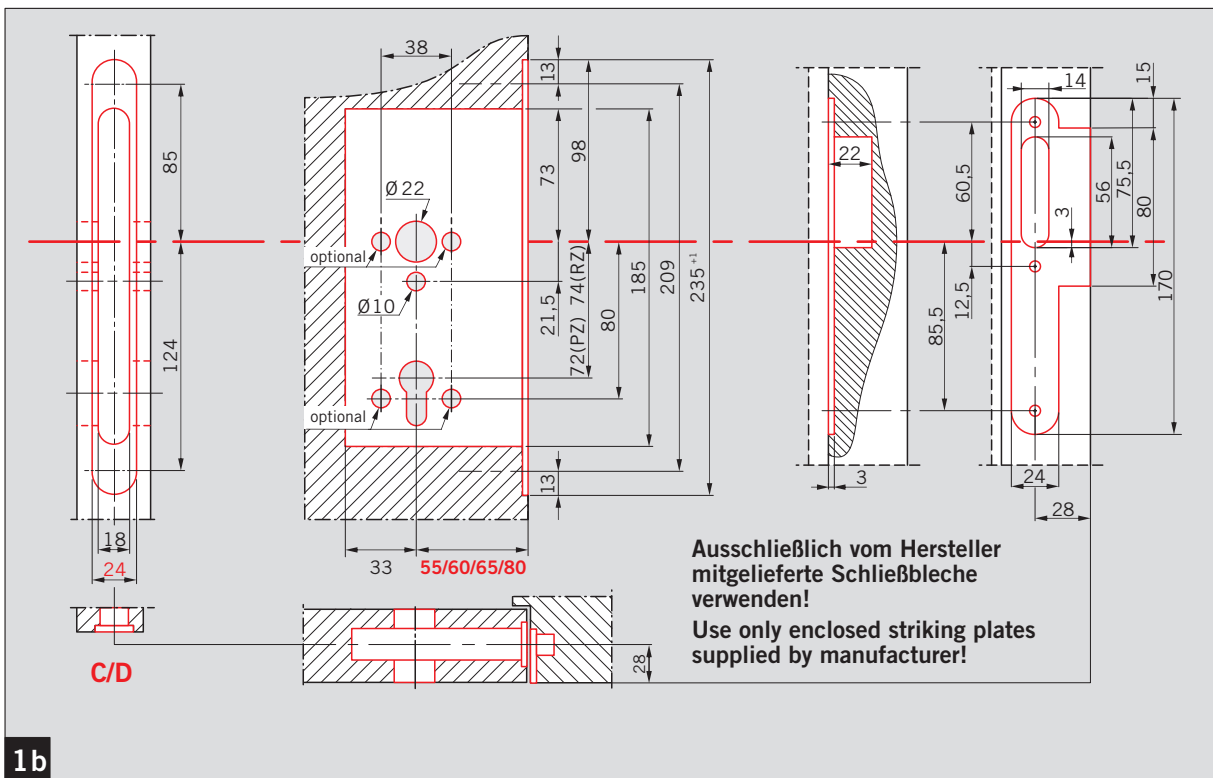
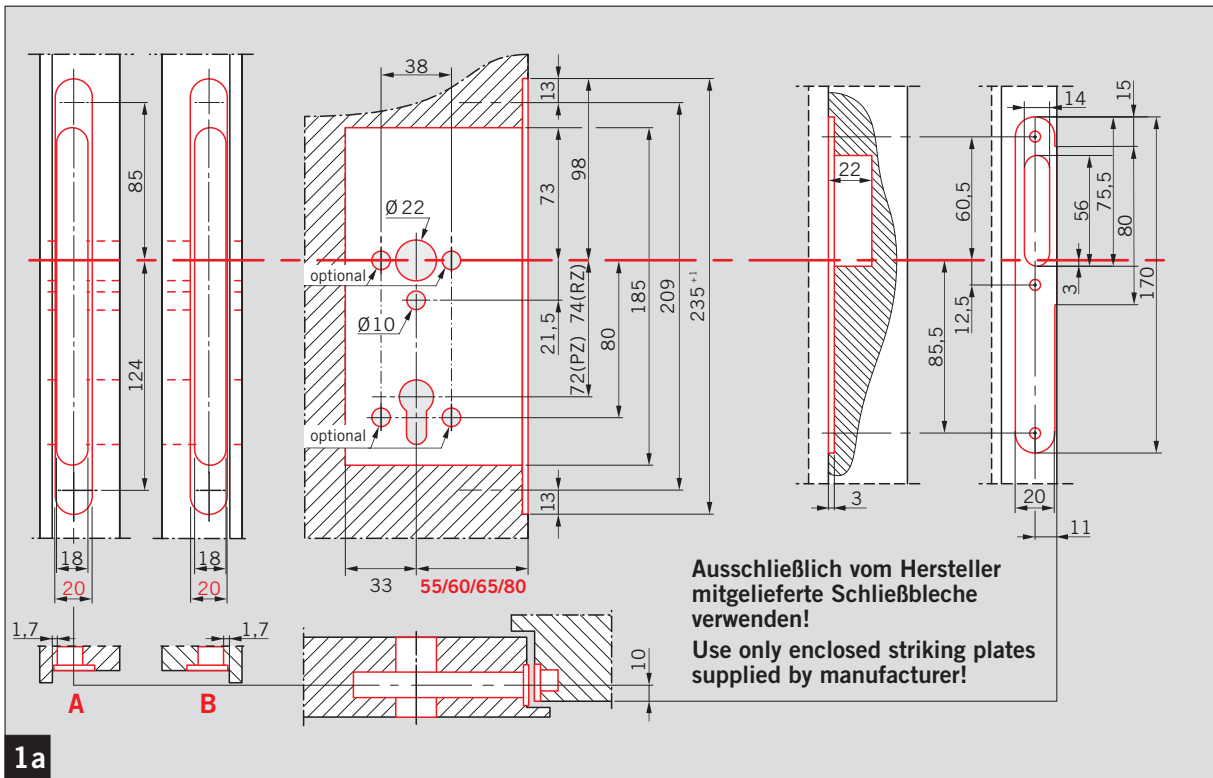
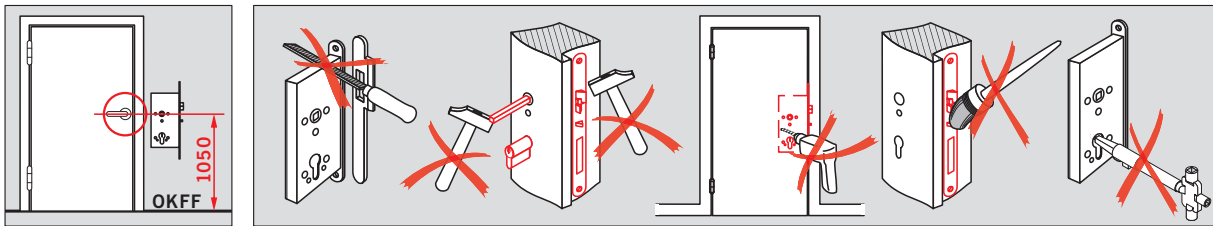

SVP 7000 Air

Montage- und Inbetriebnahmeanleitung / Mounting and commissioning instructions

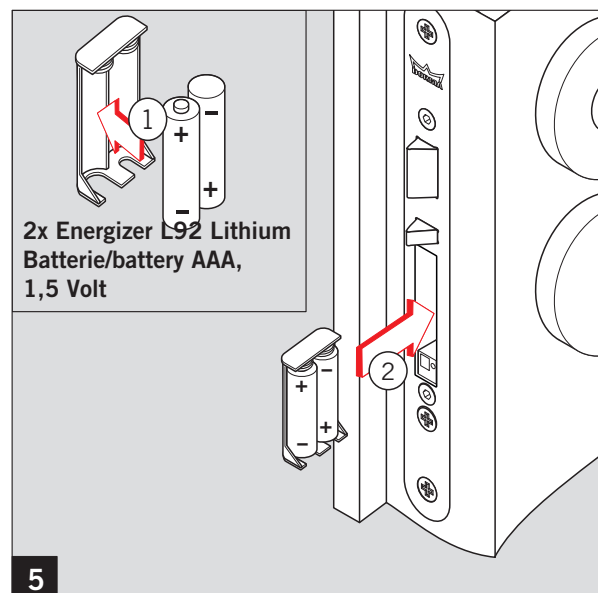
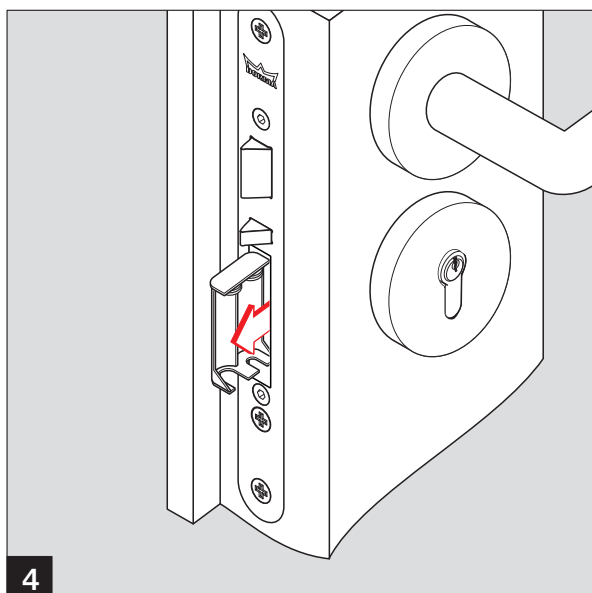
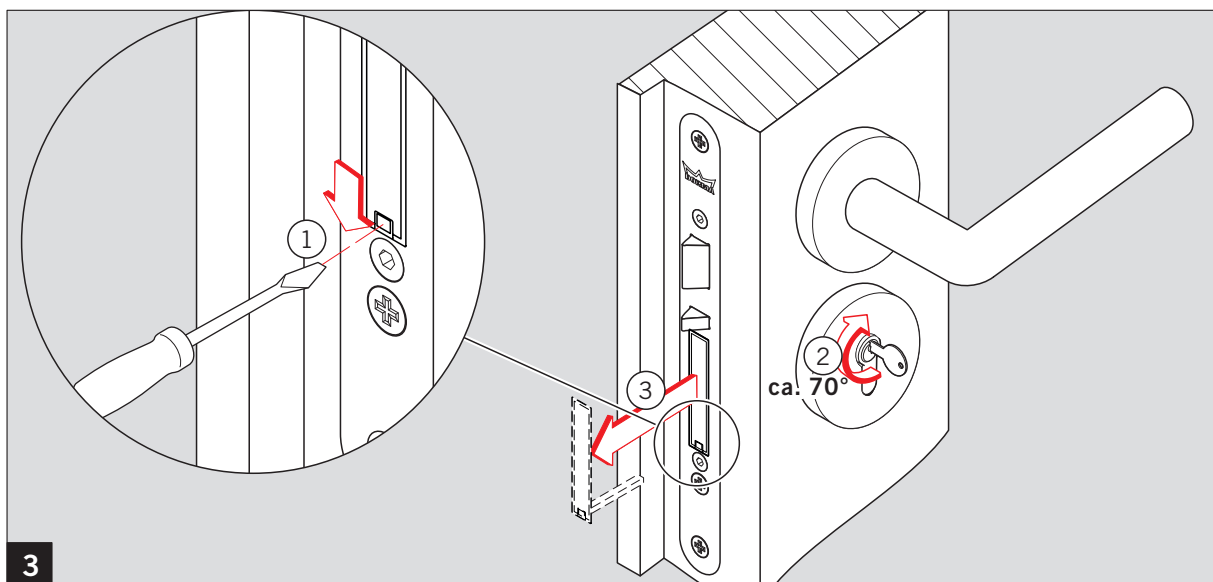
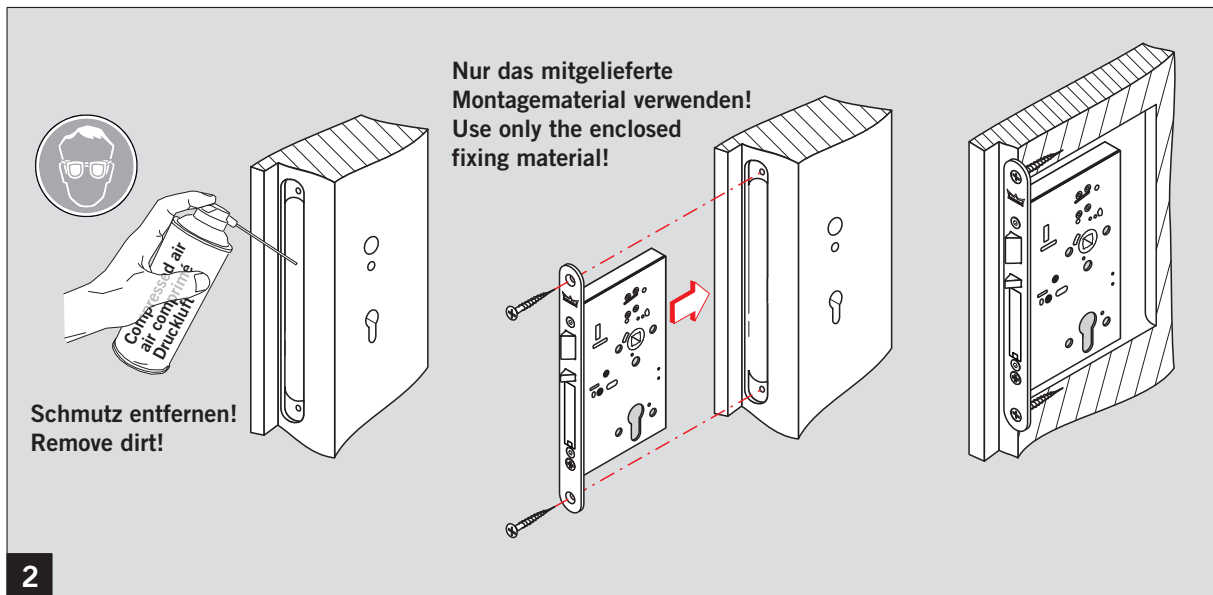

SVP 7000 Air

Montage- und Inbetriebnahmeanleitung / Mounting and commissioning instructions

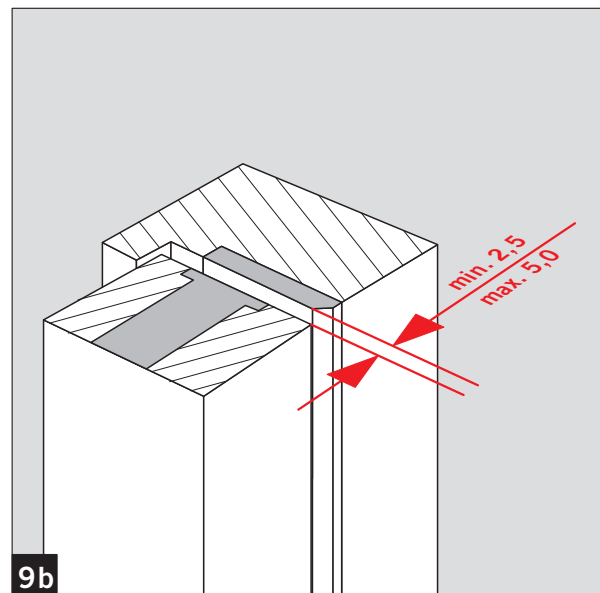
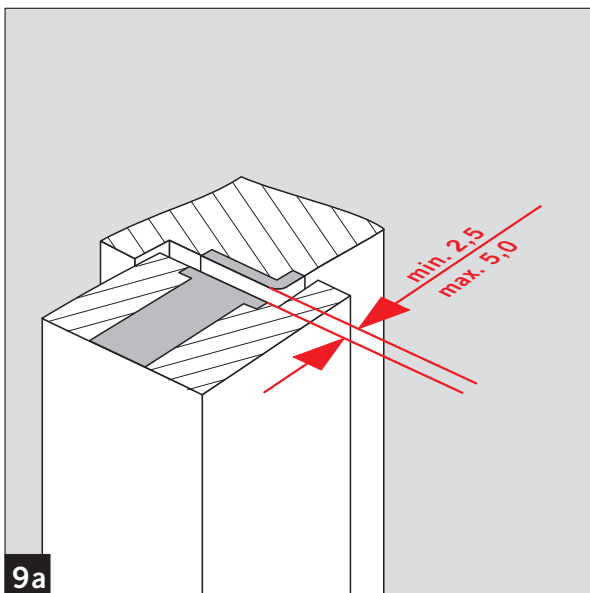
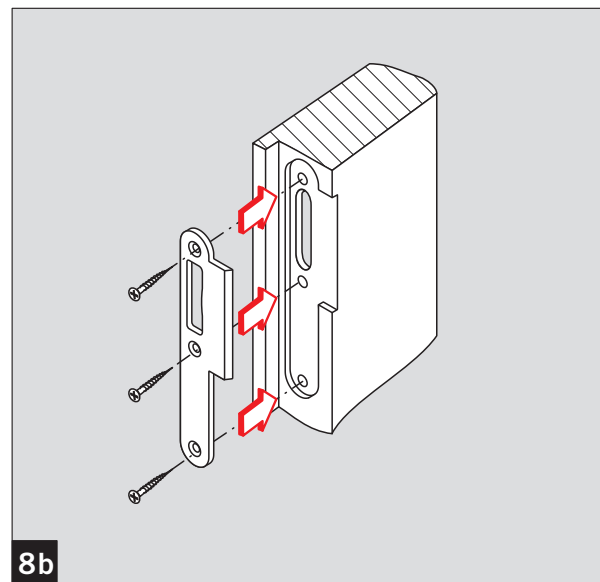
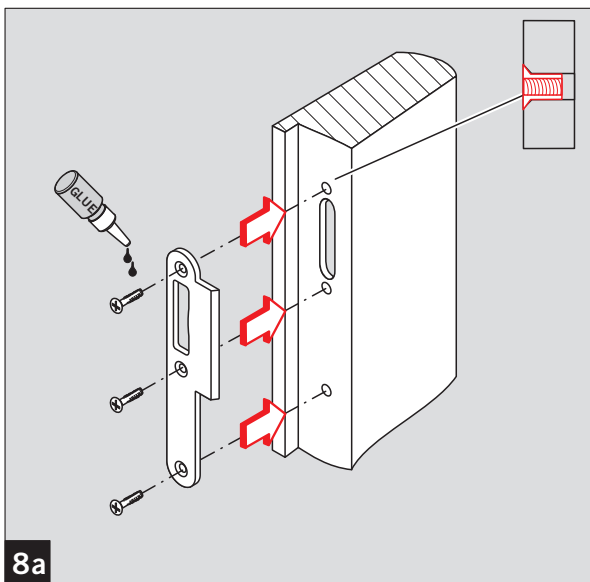
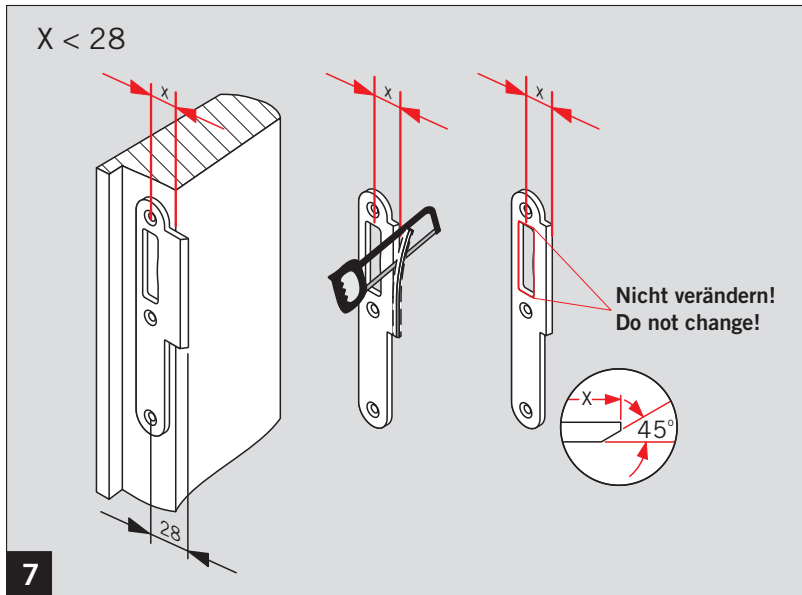
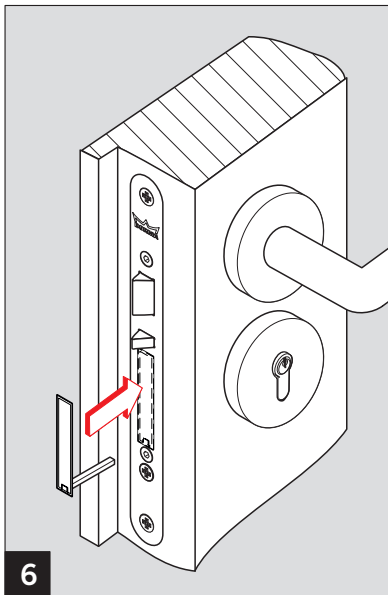

SVP 7000 Air

Montage- und Inbetriebnahmeanleitung / Mounting and commissioning instructions

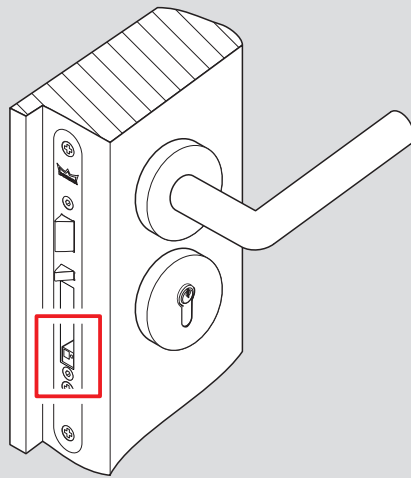

SVP Air Handsender
SVP Air hand-held transmitter

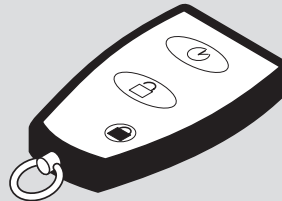

1. Einlernen eines SVP Air Handsenders / Programming of an SVP Air hand-held transmitter

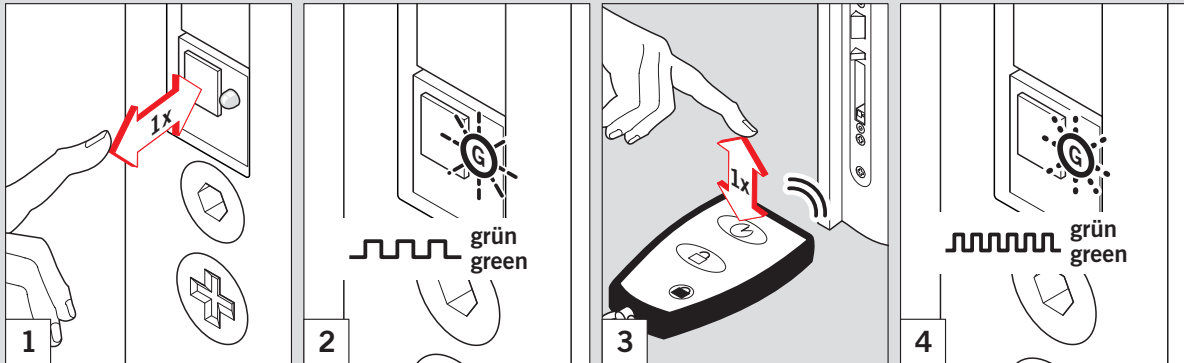

2. Löschen eines SVP Air Handsenders / Deletion of an SVP Air hand-held transmitter

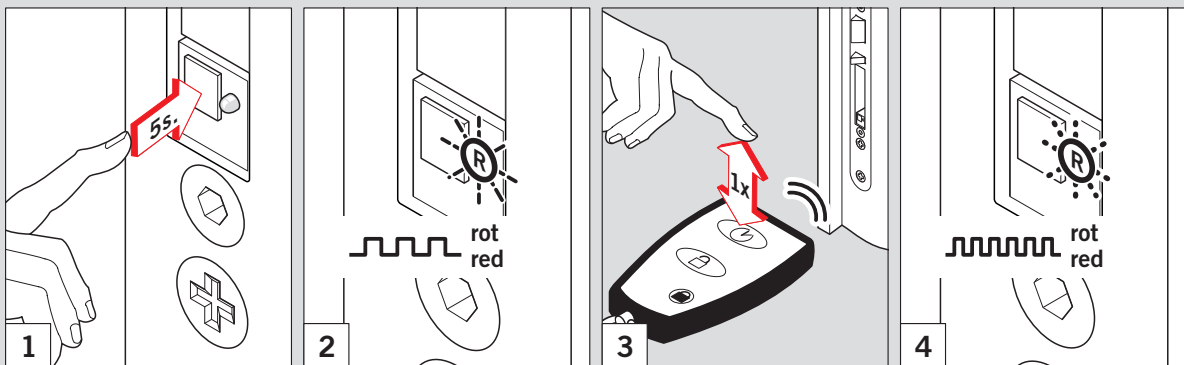

3. Löschen (Zurücksetzen) aller Handsender und SVP-S Air I/O Box / Deletion (resetting) of all hand-held transmitters and SVP-S Air I/O Box

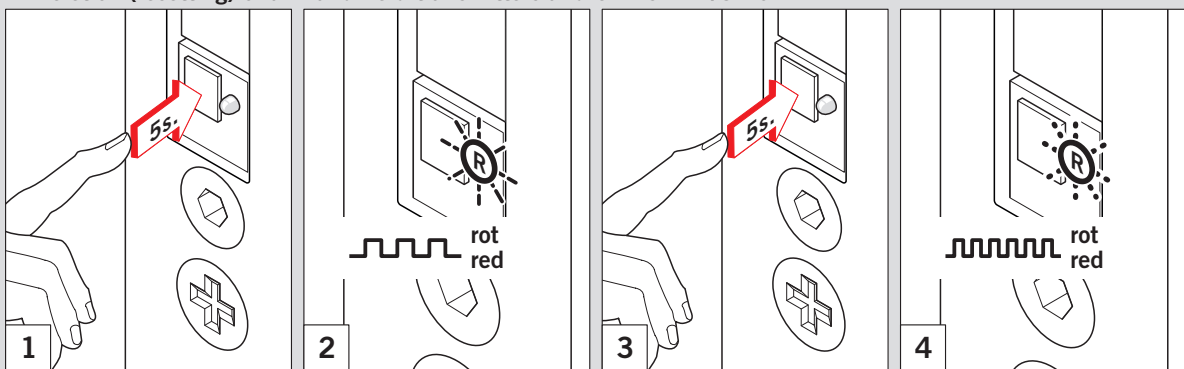

SVP 7000 Air

Montage- und Inbetriebnahmeanleitung / Mounting and commissioning instructions

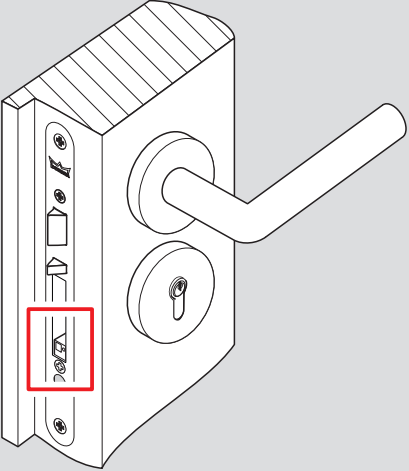

SVP-S Air I/O Box

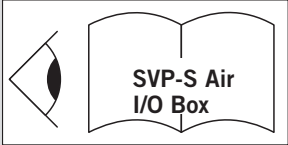
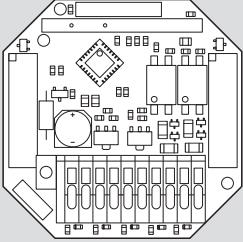

1. Einlernen SVP-S Air I/O Box / Programming of SVP-S Air I/O Box

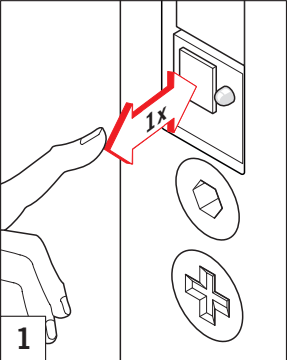
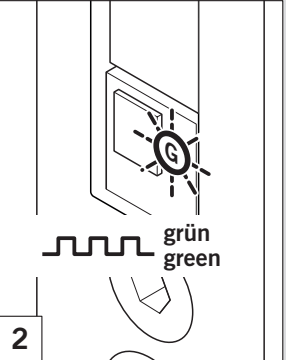
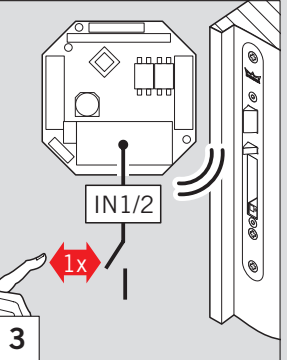
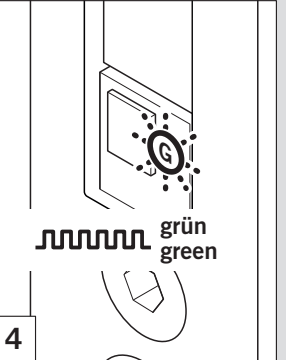
 <p>1</p>	 <p>2</p>	 <p>3</p>	 <p>4</p>
---	---	--	---

2. Löschen SVP-S Air I/O Box / Deletion of SVP-S Air I/O Box

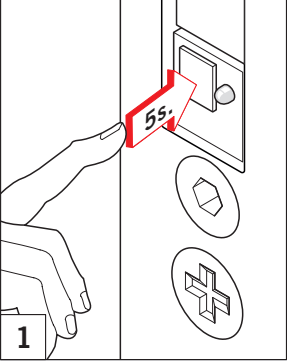
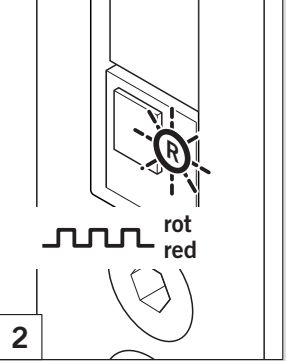
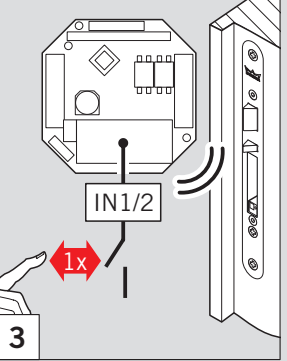
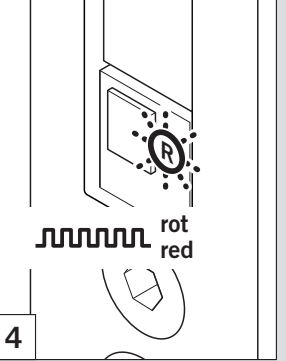
 <p>1</p>	 <p>2</p>	 <p>3</p>	 <p>4</p>
--	--	---	--

3. Löschen (Zurücksetzen) aller Handsender und SVP-S Air I/O Box / Deletion (resetting) of all hand-held transmitters and SVP-S Air I/O Box

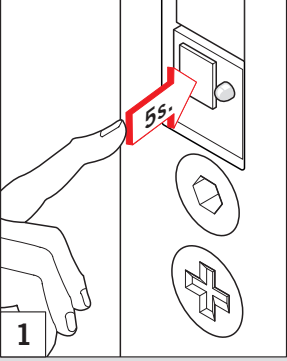
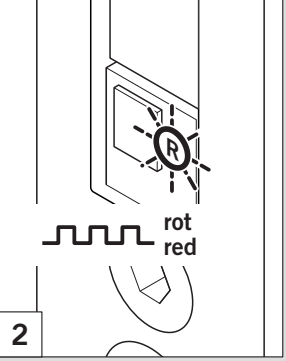
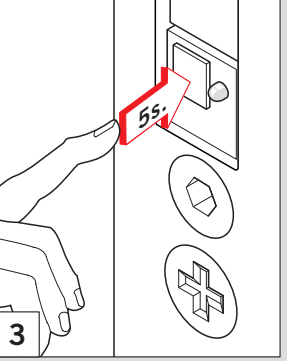
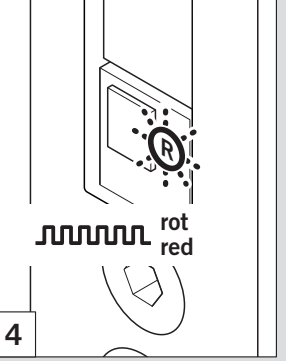
 <p>1</p>	 <p>2</p>	 <p>3</p>	 <p>4</p>
--	--	---	--

SVP 7000 Air

Montage- und Inbetriebnahmeanleitung / Mounting and commissioning instructions

Batterie austauschen

DE

Beachten Sie immer die Warnhinweise auf Batterien.
Verwenden Sie nur die empfohlenen und von dormakaba zugelassenen Batterietypen.
Achten Sie auf die richtige Polarität.

Die Batterie darf vom Bediener getauscht werden.

Beachten Sie hierzu die Montageanleitung.
Die Demontage der Batterie erfolgt in umgekehrter Reihenfolge der Montageanleitung.

Gehen Sie folgendermaßen vor, um die Batterie auszutauschen:

Replacing the battery

EN

Always note the warnings on batteries.
Use only recommended batteries approved by dormakaba.
Pay attention to the correct polarity.

The operator may replace the battery.

Please refer to the mounting instructions.
The removal of the battery is carried out in the reverse order of the mounting instructions.

Proceed as follows to replace the battery:

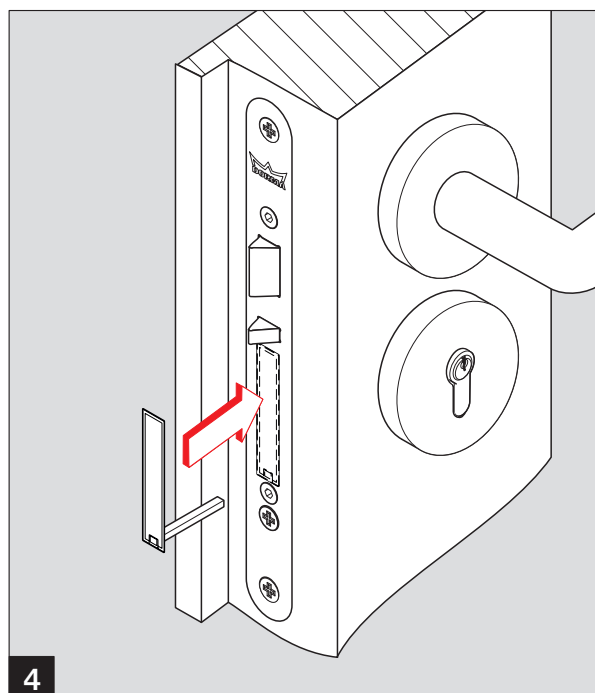
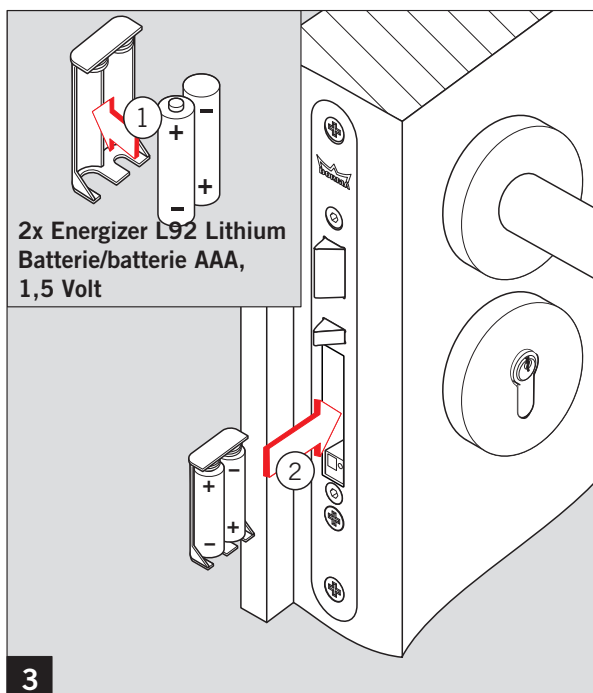
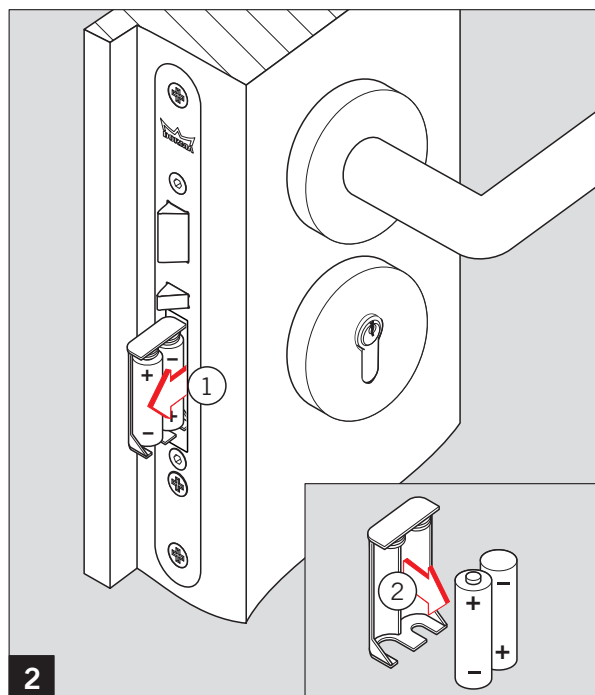
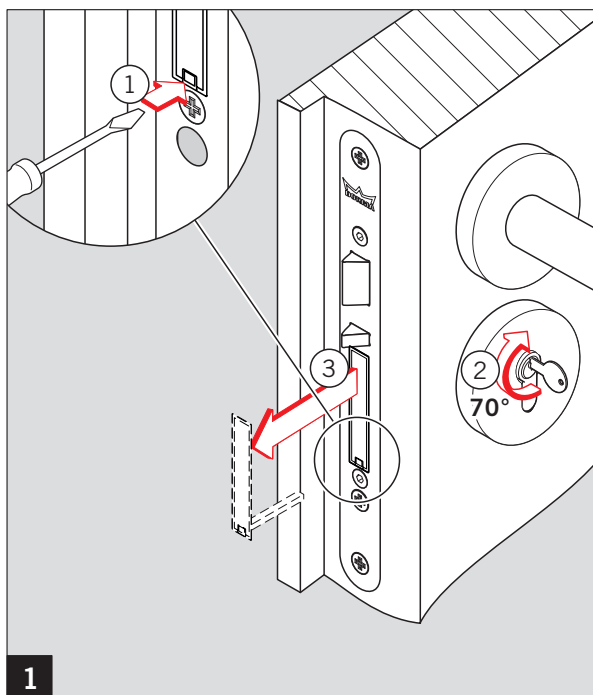

Änderungen vorbehalten
Subject to change without notice