

# Saffire™ EVO LZ-L

## Wi-Fi Cylindrical Lock



### Applications

- Add smart locks for new construction projects or retrofits
- Get real-time notifications, including events and access anomalies
- Manage access rights to allow or revoke access for residents and visitors in real-time, from anywhere
- Easily send digital keys or PIN codes to residents and visitors from a mobile device
- Residents can use their mobile device, RFID credentials, or PIN to access their residence or common areas
- Provide convenient one-time or recurring access PINs to service and maintenance personnel
- Control when and where residents and visitors can go throughout the building
- Quickly delete lost access media to keep the building secure.

### Overview

Saffire EVO LZ-L is a cloud-connected RFID lock that combines high-performance with aesthetics, seamlessly integrating with building technology providers and amenities for multihousing properties. The Saffire EVO LZ-L provides an easy-to-use, secure and flexible solution with the benefits of real-time connectivity. It includes the convenience of using either mobile devices, RFID credentials or secure PINs for access to resident units, common areas and perimeter doors.

### Security with IoT connectivity

The Saffire EVO LZ-L is equipped with Wi-Fi onboard, ensuring connectivity to the dormakaba Lyazon cloud and seamless

integration to our Lyazon partner platforms for real-time events and user notifications. Online connectivity of the Saffire EVO LZ-L also provides continuous updates for built-in device security.

### Designed for our aggregator partners

The Saffire EVO LZ product portfolio is specifically designed to be integrated with our dormakaba Lyazon partner platforms to ensure a premium user experience for multifamily residents. The dormakaba Saffire EVO LZ cloud-connected smart locks allow easy access management of residences, amenities, common areas and perimeters, all through a single integrated platform.

### Security features

- Online connectivity ensures continuous firmware updates for increased device security
- BHMA A156.2 Grade 2
- UL 10C 3-hour fire rating
- Non-volatile memory maintains lock programming and audit records
- Staff monitoring with RFID keycard audits
- Tamper-proof design
- No need to visit the lock to update access

## Factsheet

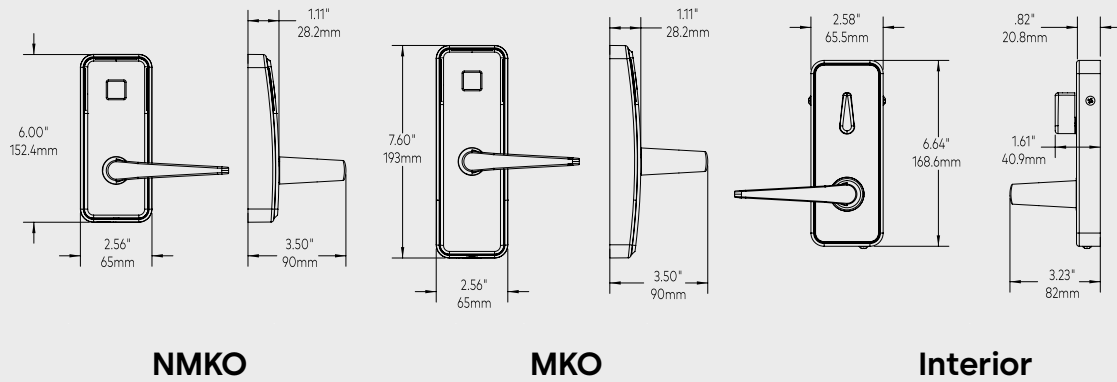

### Mechanical Features

<b>Description</b>	Online connectivity ensures continuous updates for increased device security. Supports dormakaba RFID, Bluetooth, and keypad credentials
<b>Handing</b>	Field-reversible
<b>Levers</b>	Troy, Essen, and Von levers (field-reversible).
<b>Finishes**</b>	Trim finishes: satin chrome C (626), oil-rubbed bronze Z (613), bright chrome R (625), satin nickel N (619) and black K (622)
<b>Door Thickness</b>	From 1 3/8" to 2 1/8" (35mm to 65mm)
<b>Standard Backset</b>	ASM: 2 3/4" (70mm)
<b>Batteries</b>	3AA. Low-battery indicator to help with preventative maintenance. It is visible on the device and has an event notification in the system. Passive warning and notification.
<b>Concealed Key Override</b>	Optional MKO: Lori KIK core (keyed-alike, master key)
<b>Electronic Battery Backup</b>	Electronic lock power supply (ELPS) battery back-up. ELPS part number 118-515990
<b>Wi-Fi Online Control</b>	Wi-Fi 802.11 b/g/n WPA2, WPA AES 128 and TLS 1.2 > -70dB signal strength at the lock

### Mobile Access

<b>BLE Enabled</b>	Bluetooth Low Energy 2.4 GHz version 4.2, iOS or Android mobile device support, AES 128 and DTLS security, supported through partner mobile app
--------------------	---

\*\* dormakaba utilizes PDV (physical vapor deposition) finishes in some instances

## Lock Operation

---

<b>No Touring</b>	New credentials applied to lock through Wi-Fi
<b>Electronic Access</b>	User defined: customizable access for residents, visitors and property managers available through partner application
<b>Date/time Stamp</b>	Real time: date and hours/minutes; automatically adjusts for daylight saving time
<b>Audit Trail</b>	Audit trail managed through Wi-Fi. 5,000 events
<b>Passage Mode</b>	Set by authorized key
<b>Lockout Mode</b>	Set by authorized key
<b>Toggle Mode</b>	Use of credential is needed to lock the door after exiting unit. This stops accidental resident lockouts and delivers full audit trail to ownership/management
<b>Credential Formats</b>	dormakaba ComID high-security credentials 13.56MHz MIFARE DESFire EV2/EV3 ISO card or fob/mobile access credentials (BLE) / 6-digit PIN codes
<b>Feedback LED</b>	Light indicators
<b>Diagnostics</b>	Lock diagnostics through partner application
<b>Privacy Override</b>	Default emergency key only (user selectable)

## Certifications & Testing

---

<b>Certification</b>	ANSI/BHMA A156.25, ANSI/BHMA A156.2 Grade 2
<b>Accessibility Standard</b>	* Complies with 2010 ADA Standards for Accessible Design. Must be installed according to ADA and local requirements
<b>Fire Rating</b>	Meets UL 10C and ULC S-104, on fire door rated up to and including 3 hours
<b>Electronics</b>	Compliant with RED Directive 2014/53/EU for electromagnetic compatibility and FCC part 15 and RSS-247 Industry Canada requirements
<b>Environmental Operating Conditions</b>	-31°F to 158°F (-35°C to 70°C), 0% to 90% non-condensing humidity at 86°F (30°C) meets IP54

## Warranty

---

<b>Standard Warranty</b>	Two years
--------------------------	-----------

\* Complies with 2010 ADA Standards for Accessible Design - Art. 309.4 (Operable Parts). For models with long lever only. Lock shall be properly aligned with the mortise or latch and must be installed strictly according to the dormakaba installation instructions and the ADA Standards and Regulations applicable for each facility, to be able to fulfill compliance with ADA requirements.

---

**Any questions? We would be happy to advise you.**

Contact us at: 1 800 849 8324