

1816 HJ SD & SFJ SD

Surface applied door closer

HJ (stnd jamb mount) x DP with smoke detector

SFJ (swing free jamb mount) x DP with smoke detector

Installation instructions

08220890 – 03-2020

| EN |







dormakaba 

Table of contents

1	Technical specifications	3	5	Final set up	18
1.1	Overview	3	5.1	Detector sensitivity test (ULC required only)	18
1.2	Tools recommended	3	5.2	Check connections	18
2	Installation instructions	4	5.3	Engage hold open	18
2.1	Overall	4	5.4	Reset detector	18
2.2	Install main arm	5	5.5	Unit testing	19
2.3	Install closer (top jamb mount)	6	5.6	Install covers	19
2.4	Install closer (top jamb mount x drop plate)	7	6	Maintenance	19
2.5	Smoke detector attachment	7	6.1	Maintaining the detector	19
3	Adjustments	8	6.2	Measure and record test voltage	20
3.1	Adjust closing speeds: sweep, latch, backcheck, delayed actions	8	6.3	Vacuum detector	20
3.2	Set the hold open	8	6.4	Testing (continued)	21
4	Wiring	9			
4.1	Electrical specifications	9			
4.2	Power supply 120 VAC, 50/60 Hz	10			
4.3	Power supply 24 VAC/DC	10			
4.4	Power supply 24 VAC/DC with remote detectors	11			
4.5	ON/OFF switch (optional)	11			
4.6	Wire gauge	12			
4.7	SD-2 detector to main solenoid connection	13			
4.8	SD-2 detector to auxiliary solenoid connection	13			
4.9	Solenoid attachment to UL/ULC listed fire alarm control panel	13			
4.10	SD-2 detector interconnection	14			
4.11	SD-2 detector to remote area detector	15			
4.12	SD-2 detector to audible signal appliance	15			
4.13	SD-2 detector to remote alarm indicator lamp	16			
4.14	Alarm initiation wiring 4 wire style B (Class B) & 6 style D (Class A)*	16			

1 Technical specifications

1.1 Overview

-  Each 1816 HJ SD & SFJ SD unit contains a door closer, hold open solenoid and a smoke detector .
-  The unit can be used as a single installation or as a series of devices. When the units are wired together in a run, up to 5 may be interconnected. Interconnections are accomplished through terminals #4 and #15 resulting in all alarming when any one unit senses smoke. In turn, all associated hold open solenoids are de-energized. Within any run smoke detecting units it is permissible to form as many interconnected series as the total power supply amperage will allow; but again no more than 5 can be interconnected.
-  Any unit with a smoke detector can be connected to a non-smoke detector unit, or a remote detector, or both. It can be a single installation or part of any of the multiple arrangements described above. A non-smoke detector solenoid is a slave to the main unit de-energizing when the main does. Single or group installations can be connected to the alarm initiation circuit of a compatible UL/ULC listed fire alarm control 4 or 6 wire configuration panel.
-  Additional functions are provided to separately power the hold open solenoids directly from the alarm control panel or remotely from a alarm indicator lamp.
-  **ATTENTION!!!** Read the entire instruction sheet prior to installing and refer to NFPA 72E. Standards may be obtained from THE NATIONAL FIRE PROTECTION ASSOCIATION in Batterymarch Park, Quincy, Massachusetts, 02169.
-  Please make sure you have the tools listed plus make sure you have the correct model unit and hand designation per your application.
-  **CAUTION:** Sex nuts are required for attachment of components to unreinforced, wood or plastic faced composite type fire doors, unless an alternative method is identified in the individual door manufacture's listings. Make sure door efficiently operates prior to installing the closer. When Installing main arm attachment observe directions closely. Confirm dead stop degree prior to door and frame preparations.

1.2 Tools recommended

Table 1

Drill bits:	#3 Phillips screwdriver
No. 7 drill bit & drill or 13/64" drill bit	3/16" slotted head screwdriver
1/4-20 tap & holder	M5 hex key
1/2" box wrench	
10" adjustable wrench	

2 Installation instructions

2.1 Overall

Fig.1

Left hand installation

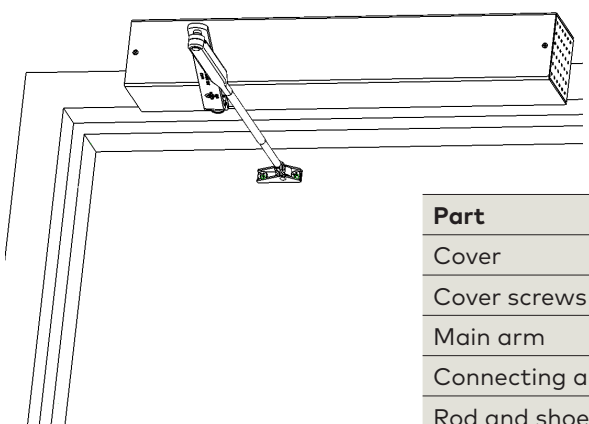

Right hand installation

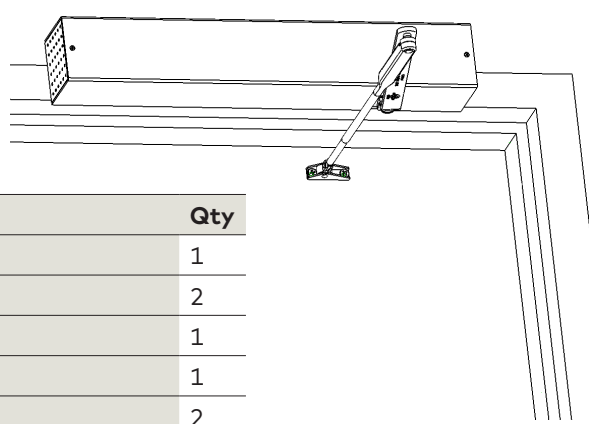

Part	Qty
Cover	1
Cover screws	2
Main arm	1
Connecting arm	1
Rod and shoe	2
1816 unit (HJ or SFJ - LH/RH)	1
Combo screws	5*
Flat head wood screws	2*
Flat head machine screws	2*
Hex washer head screw (HJ only)	1
Rubber stop	1
Smoke detector	1
Standoffs	5
Standoff screws	5
Free Swing Unit Parts	
Qty	
Socket head cap and washer	1
Bushing	1
Anti friction washer	2
Sweep arm	1
*drop installation uses a total quantity of 7 combo screws (7)	

2.2 Install main arm

Fig.2

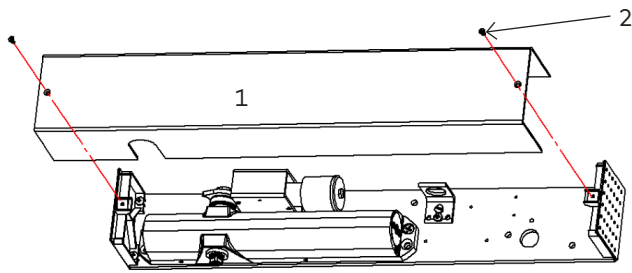

2.2.1 Remove the cover (1) by unscrewing the two Phillips screws (2).

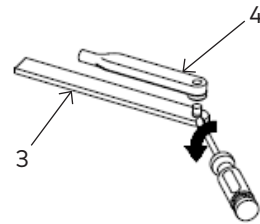

2.2.2 Pry apart connecting arm (4) tube from main arm (3).

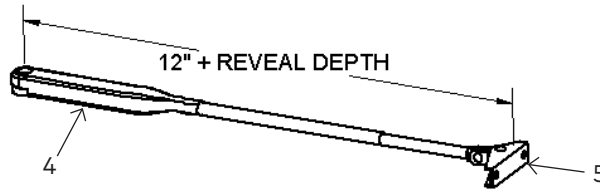

2.2.3 Thread the connecting tube (4) and rod shoe (5) together.
Length = 12" plus the reveal depth

Left hand installation

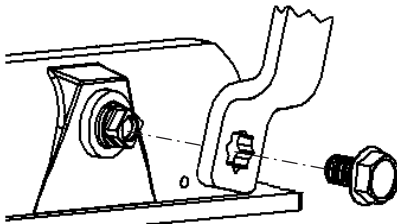

Hold Open Jamb Mount:

2.2.4 Attach main arm (3).
2.2.5 Secure tightly with hex head washer screw (9).
Note: indexing by hand of unit.

Right hand installation

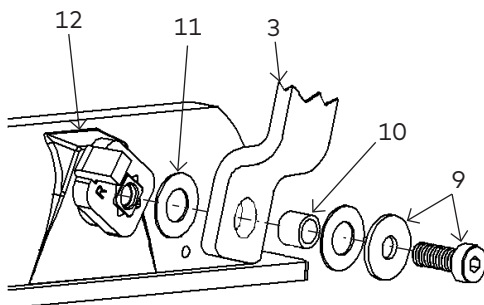
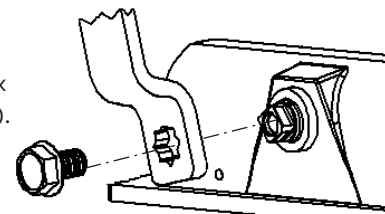

Free Swing Mount:

2.2.6 Attach swing arm (12) as shown, by inserting the bushing (10) into the main arm (3).
2.2.7 Apply two anti-friction washers (11) on both sides of the main arm.
2.2.8 Tightly secure with socket head cap screw and washer (9).

Note: indexing by hand of unit.

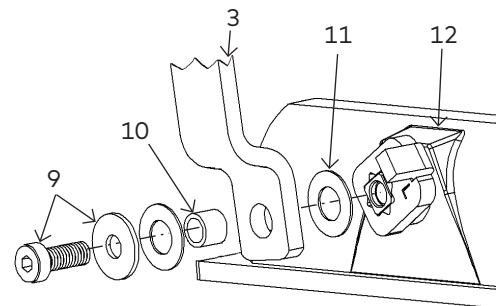

2.3 Install closer (top jamb mount)

Fig.3

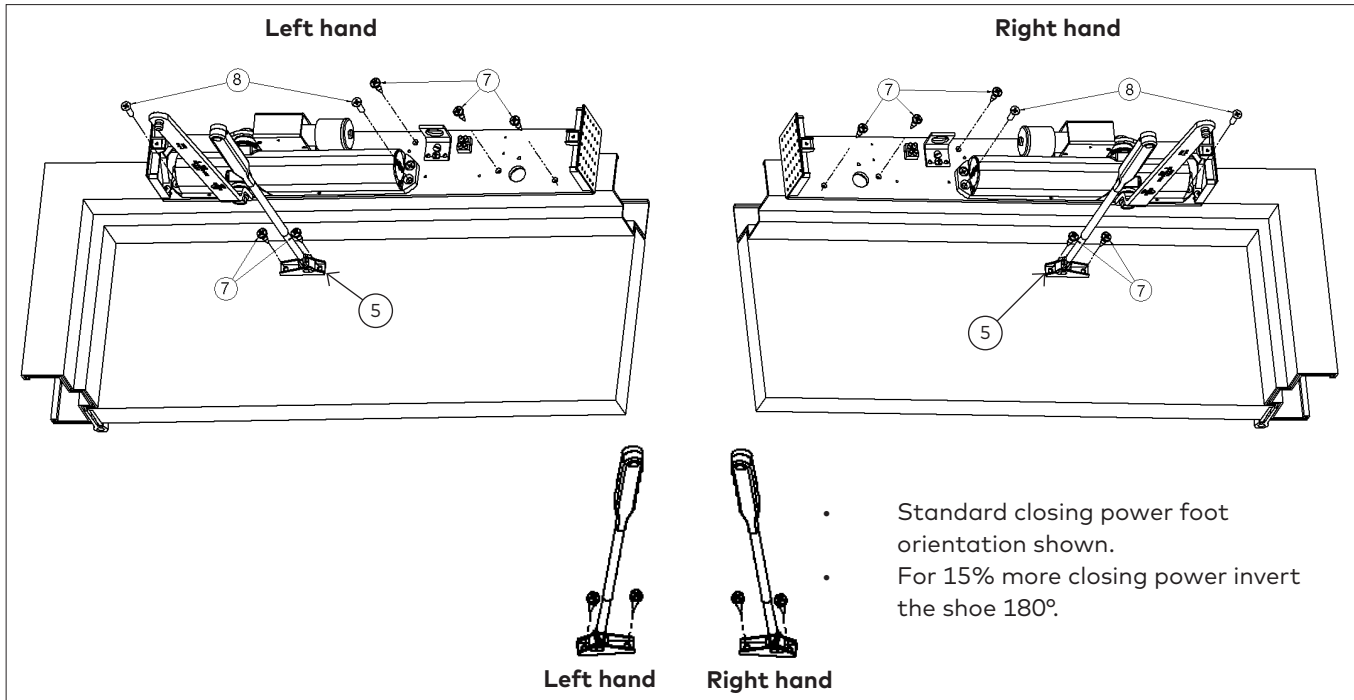

- 2.3.1 Prepare door and frame using the template provided.
- 2.3.2 Attach unit (6) to frame with 3 combo screws (7) and 2 flat head wood screws (8) or 2 flat head machine screws (8).

- 2.3.3 Attach rod and shoe (5) to door with 2 combo screws (7).

2.4 Install closer (top jamb mount x drop plate)

Fig.4

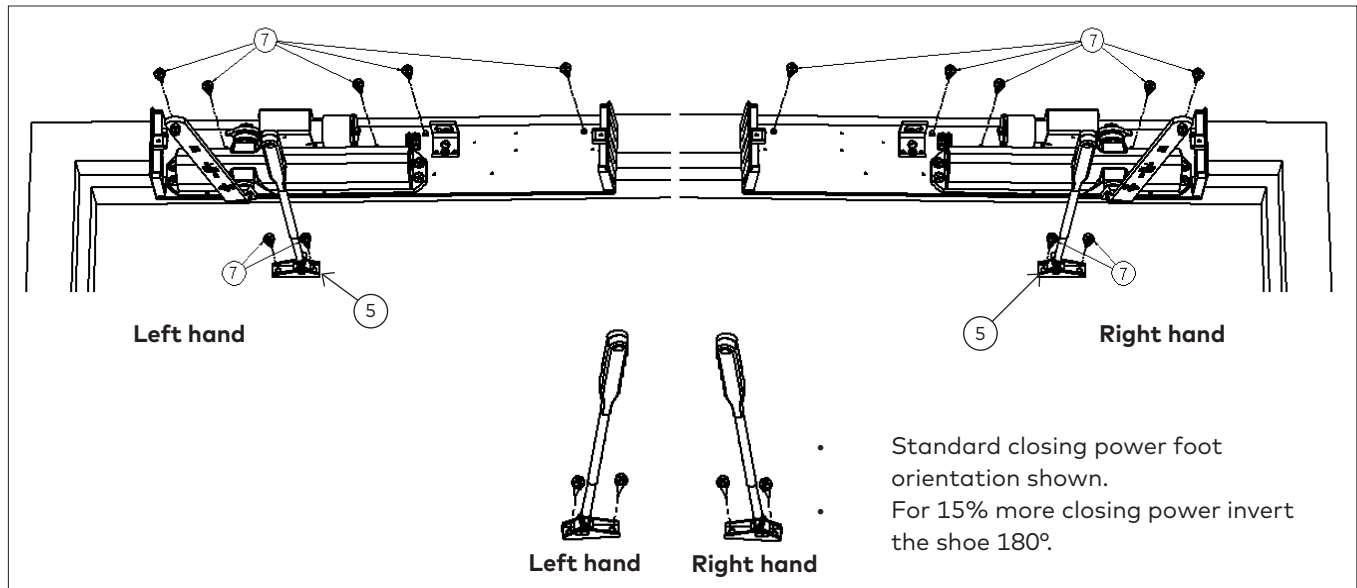

2.4.1 Prepare door and frame using the template provide.

2.4.2 Attach unit (6) to frame with 5 combo screws (7).

2.4.3 Attach rod shoe (5) to door with 2 combo screws (7).



2.5 Smoke detector attachment

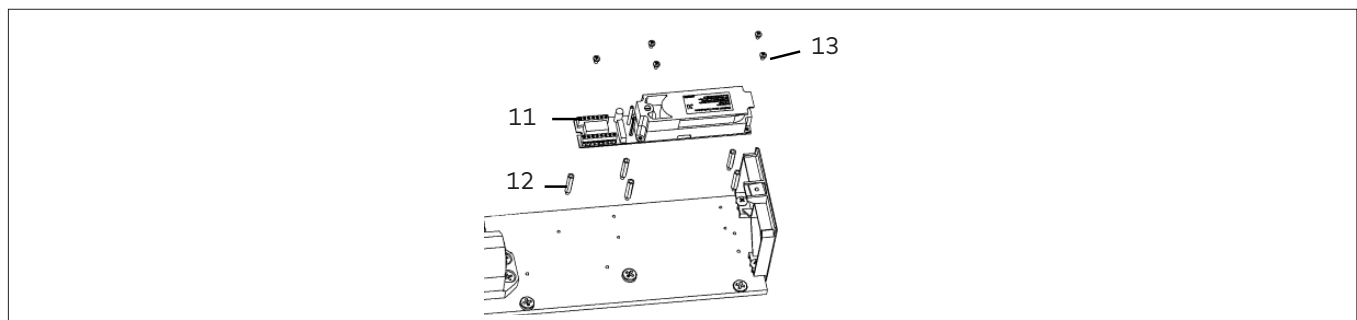



Fig.5



2.5.1 Insert five standoffs (12) into mounting plate. Fasten detector (11) with five screws (13) provided.

3 Adjustments

-  Be sure closer has appropriate spring power prior to making any closer speed adjustments.
-  Door should close in 3 to 6 seconds from 90 degrees
-  Do not back valves out beyond closer casting surface.

-  Check closing sweep (S) and latch (L) speed; adjust as necessary.
-  Backcheck position will advance approximately 15 degrees by placing position valve in the "on" position (fully clockwise).
-  Check delay action (DA) function if supplied.
-  Ball bearing hinges or pivots should always be used.

3.1 Adjust closing speeds: sweep, latch, backcheck, delayed actions

Fig.6

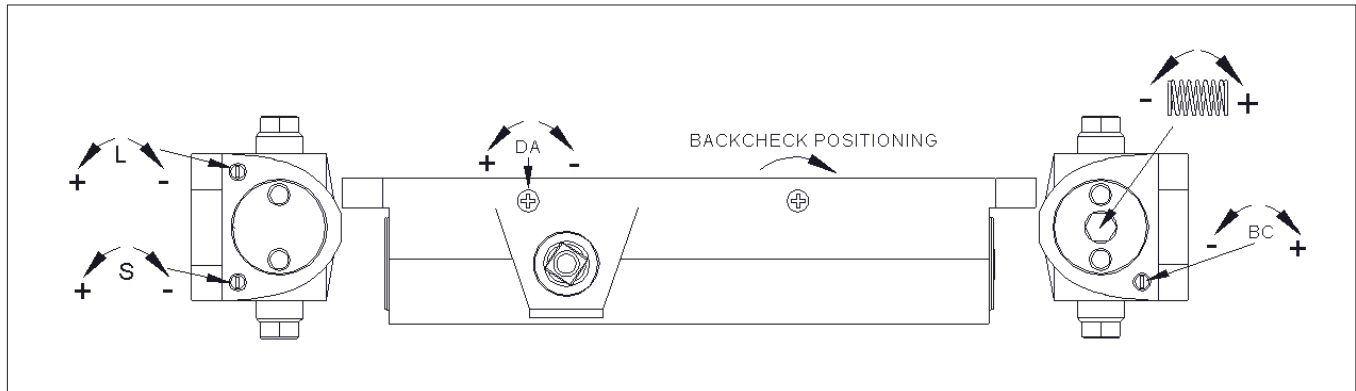

Closer size	Max door weight (lbs)	Door width		Full turns
		Interior	Exterior	
2	100	2'-6"	---	-6
3	125	3'	2'-6"	0
4	150	3'-6"	3'	+8
5	200	4'	3'-6"	+16
6	250	---	4'	+24

3.2 Set the hold open

Fig.7

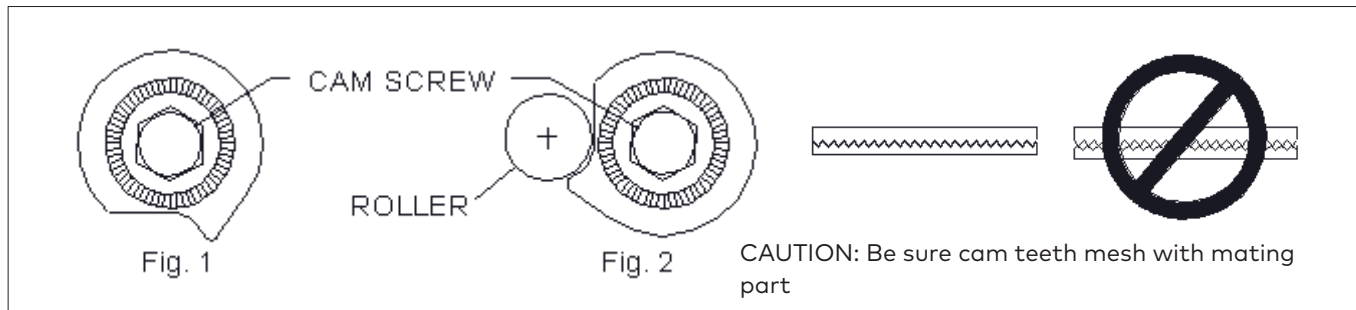

3.2.1 Open the door to factory preset hold open position at 90 degree approximately.

3.2.2 Loosen cam screw so the cam moves freely. (Fig. 1)

3.2.3 Move door to the required hold open position.

3.2.4 Turn cam so that the cam lobe is resting against the roller in the plunger. Tighten cam screw securely. (Fig. 2)

4 Wiring

4.1 Electrical specifications

Fig.8

DISCONNECT ALL POWER BEFORE INSTALLATION BEGINS TO PREVENT ELECTRICAL SHOCK AND COMPONENT DAMAGE. INSTALLATION MUST BE PERFORMED BY TRAINED EXPERIENCED SERVICE PERSON.

WIRE THE UNITS ACCORDING TO BUILDING AND SYSTEM REQUIREMENTS. OBSERVE ALL APPLICABLE CODES.

Voltage input	24 VDC +10% - 15% 24 VAC +10% - 15% 120 VAC +10% - 15% to transformer
Maximum input current	@24 VDC- 105 mA (1 solenoid), 275 mA (2 solenoids) @24 VAC- 185 mA (1 solenoid), 350 mA (2 solenoids) @120 VAC - 50/60Hz - 40 mA (1 solenoid), 70 mA (2 solenoids)
Maximum output to remote alarm indicator lamp	300 mA
Contact ratings	Alarm and or accessory contacts: 1.25 A @ 24 VDC or 0.3 A at 120 VAC resistive maximum. (Alarm and/or accessory contacts) Trouble contacts: 500 mA at 24 VDC resistive maximum.

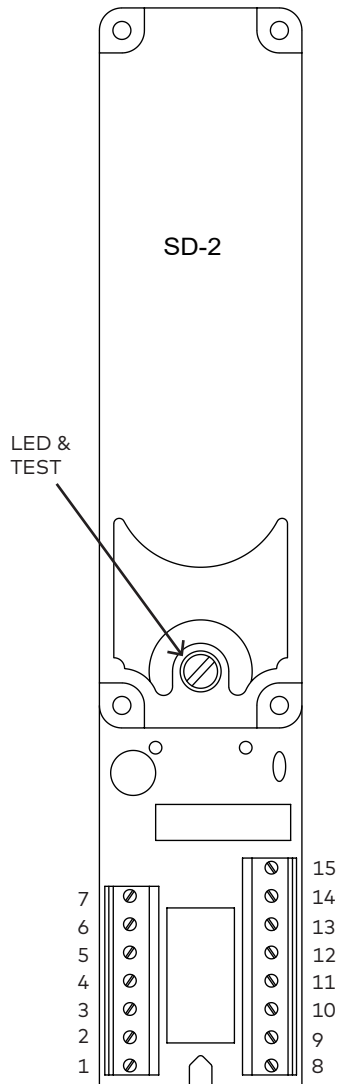

Optional 120V Transformer

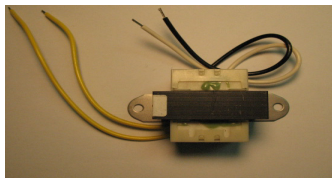

Yellow wires go to terminal block.
120V in-coming power

Optional Surface Wiring

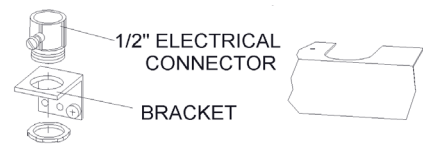

Optional surface wiring must be specified when the unit is ordered. The surface wiring bracket is added for installation of the 1/2" electrical conduit connector and the cover is notched to accept the conduit.

Note:

- **Terminals 4, 6, & 7 are same point.**
- **Form C relays are SPDT and break the connection with one throw before making contact with the other (break-before-make).**

This unit includes a 4-wire, photoelectrical type smoke detector. It provides: smoke detection, door hold open control, normally open (N.O.) alarm contacts, normally closed (N.C.) supervisory contact and interconnection to other smoke detectors. Field option: one form C relay (cut jumper wire as noted below). See following pages for alternate connection schematics.

Detector control list	
Function	Terminal
AC/DC 24V INPUT	3(-), 14(+)
ALARM CONTACTS	1, 2
SOLENOID + (POS)	9 (N.C.)
SOLENOID - (NEG)	6
REMOTE ALARM INDICATOR LAMP + (POS)	8 (N.O.)
REMOTE ALARM INDICATOR LAMP - (NEG)	7
INTERCONNECT + (POS)	15
INTERCONNECT - (NEG)	4
TROUBLE CONTACTS (NORMALLY CLOSED)	5, 13
24 VDC OUTPUT (UNFILTERED) +	10

IF JUMPER WIRE J11/J12 IS CUT, TERMINALS 8, 9 AND 10 ARE CHANGED TO FORM C RELAY CONTACTS, RAIL OUTPUT IS LOST, AND HOLD OPEN SOLENOIDS MUST BE POWERED FROM A SEPARATE SOURCE. CONSULT FACTORY IF REMOTE DETECTORS ARE USED IN THIS APPLICATION.

4.2 Power supply 120 VAC, 50/60 Hz

Fig.9

120 VAC, 50/60 HZ: Connect the 120 VAC incoming voltage wires to the primary wires of the transformer. Connect the secondary transformer wires to terminals #3 and #14 of the detector module. This connection is not polarity dependent.

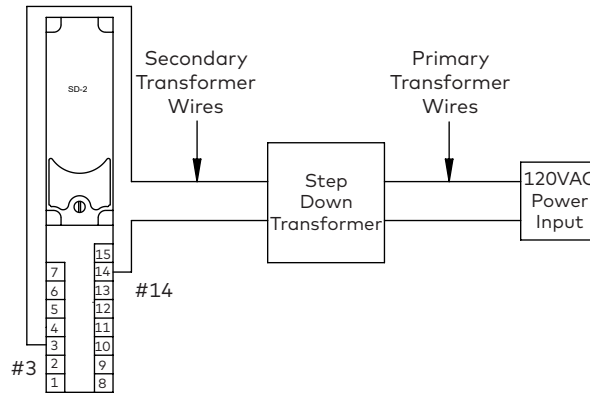

4.3 Power supply 24 VAC/DC

Fig.10

24V AC/DC: The step down transformer is not used in this connection. Connect 24V AC/DC power to terminals #3 and #14 on the detectors. These connections are not polarity dependent. If the unit is connected to a second unit, connect terminal #3 of the first unit to terminal #3 of the second unit and connect terminal #14 of the first unit to terminal #14 of the second unit. Continue this process for any subsequent units to be powered from the same power supply.

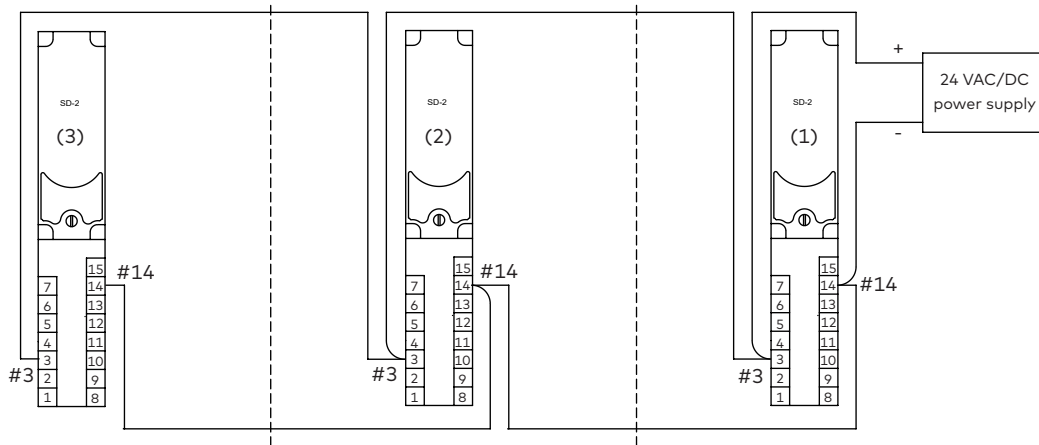

4.4 Power supply 24 VAC/DC with remote detectors

Fig.11

24V AC/DC with remote detectors: The step down transformer is not used in this connection. Perform wiring connections as illustrated below. Additional units are wired in the same manner as unit #2. Installations using a combination of SD-2 modules with and without remote area detectors can be wired accordingly by substituting the wiring diagram section from unit #1, #2, or #3 in step 4.11 instead of unit #1, #2, or #3 shown below with remote detector. The vertical dashed lines indicate where one diagram would be exchanged for another.

NOTE: Input voltage must match detector voltage. Detector voltage 24V AC/DC.

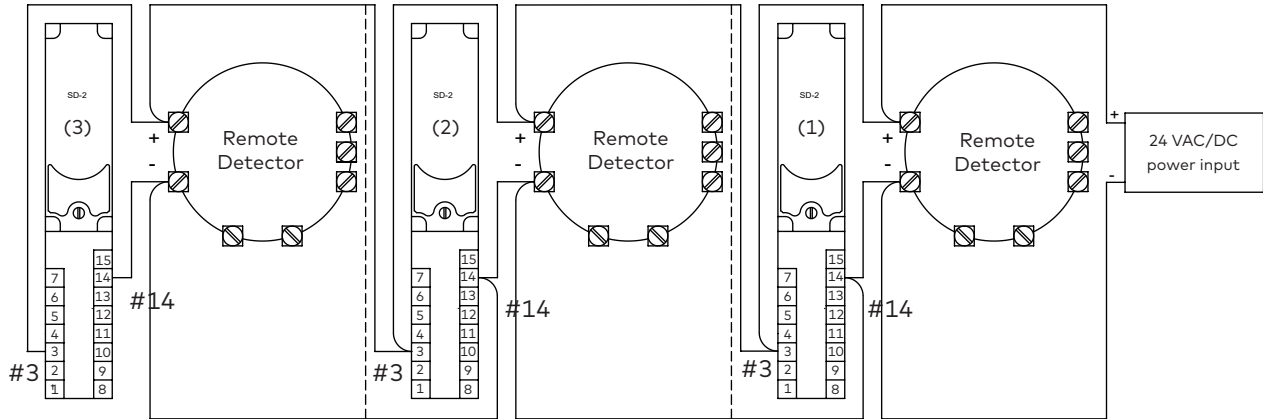

4.5 ON/OFF switch (optional)

Fig.12

1. Wire ON/OFF switch as shown at the right.
2. Push button will cut power to the hold open solenoid and the door will close.
3. Pushing button a second time will engage power to the hold open solenoid allowing the door to be held open.
4. The push button is accessible by inserting a small cylindrical object thru the hole small hole in end cap.

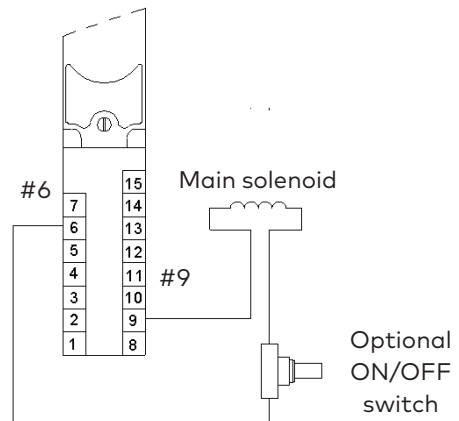

4.6 Wire gauge

Fig.13

Wire gauge: The maximum wire gauge for wiring the SD-2 detector module is #18 AWG. The method for determining wire gauge is given below. NOTE: A minimum of 20.4 VDC must be supplied to each solenoid in the run.

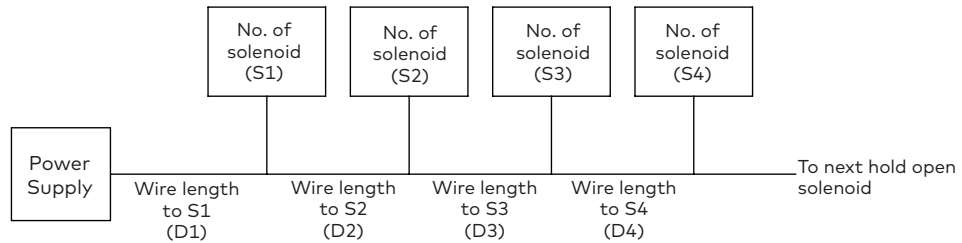

S1, S2, S3, etc. are the number of solenoids at each subsequent station. D1 is the distance from the power supply to the first solenoid station. D2, D3, D4, etc. are the distances from the previous solenoid station to the next solenoid station in the run. To determine the correct wire gauge multiply S1 times D1. Add that quantity to S2 times D2. Repeat the same procedure for each solenoid to test the last unit in the run. Compare the quantity calculated to the chart below. The calculated value must be less than or equal to the value corresponding to the appropriate wire gauge.

10 GAUGE-11,788 12 GAUGE-7,407 14 GAUGE-4,669 16 GAUGE-2,997 18-GAUGE-1,843

The procedure described above can be expressed in the following equation: $(S1 \times D1) + (S2 \times D2) + (S3 \times D3) + \dots + (Sn \times Dn)$. The above values correspond to the wire gauge to be used. If the calculated value 1,843 #18 AWG wire can be run and connected directly to the detector module. If the calculated value exceeds 1,843 larger wiring will be required. Since the detector will only accept #18 AWG wire, a wiring splice will be necessary as illustrated below.

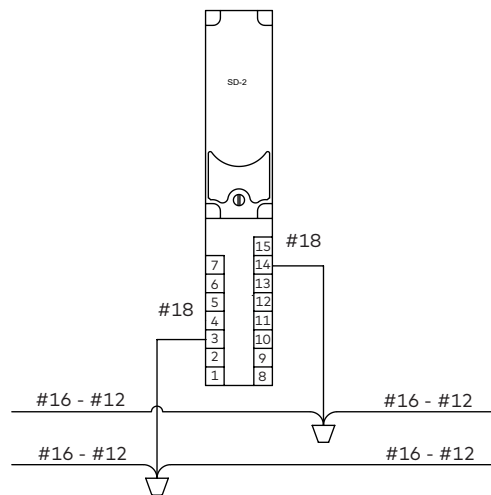

NOTE: For ULC installations, 18 gauge wire is required to detector.

4.7 SD-2 detector to main solenoid connection

Fig.14

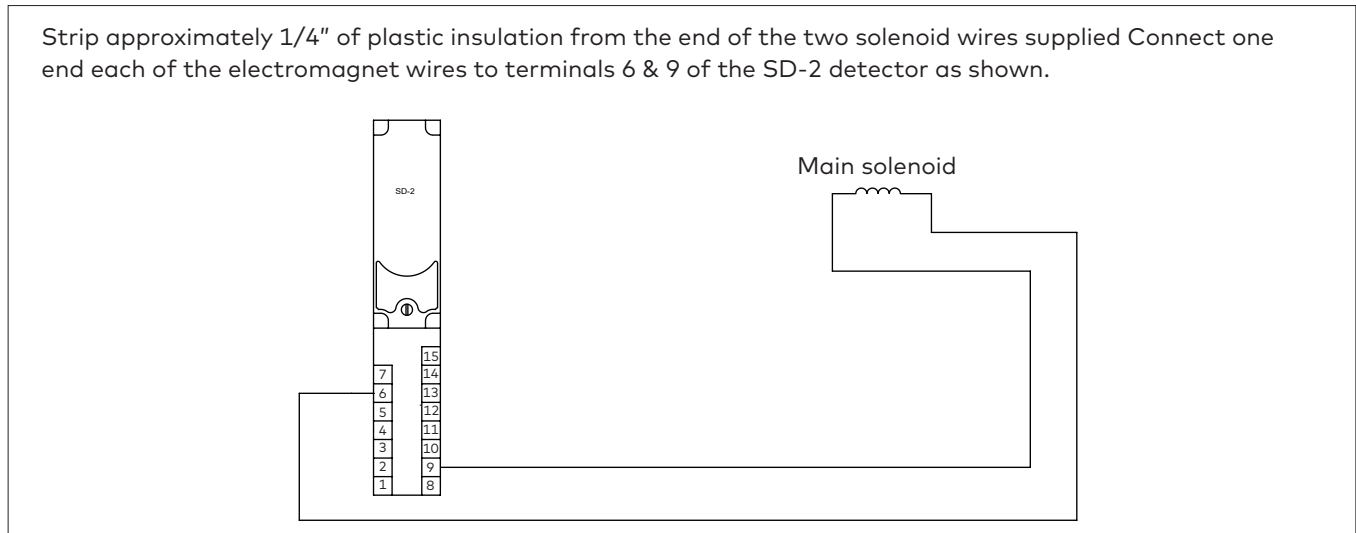

4.8 SD-2 detector to auxiliary solenoid connection

Fig.15

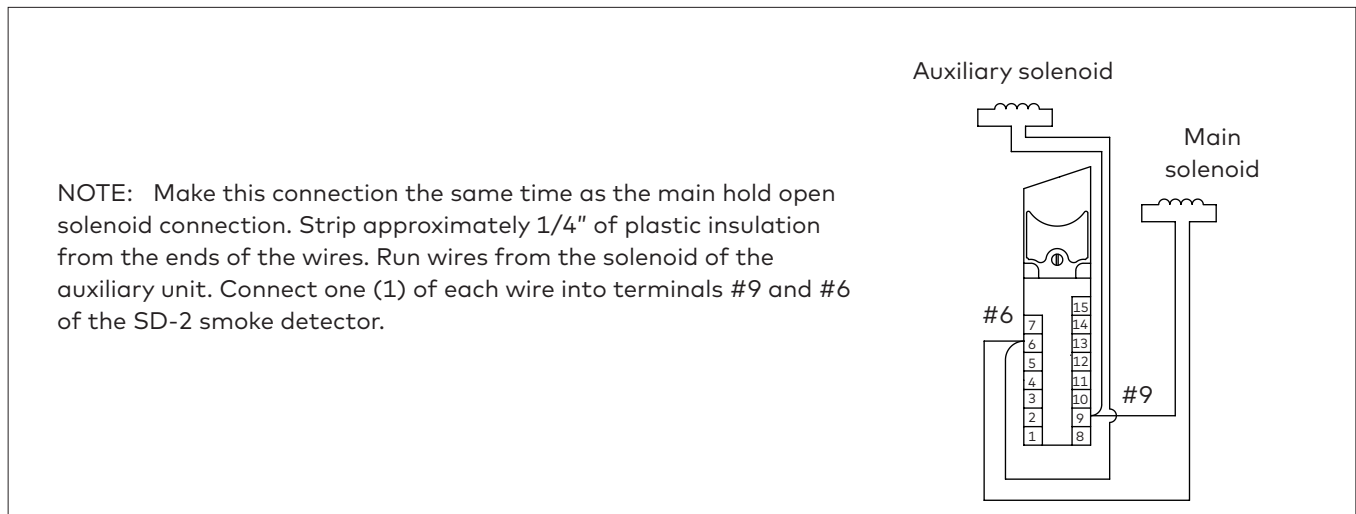

4.9 Solenoid attachment to UL/ULC listed fire alarm control panel

Fig.16

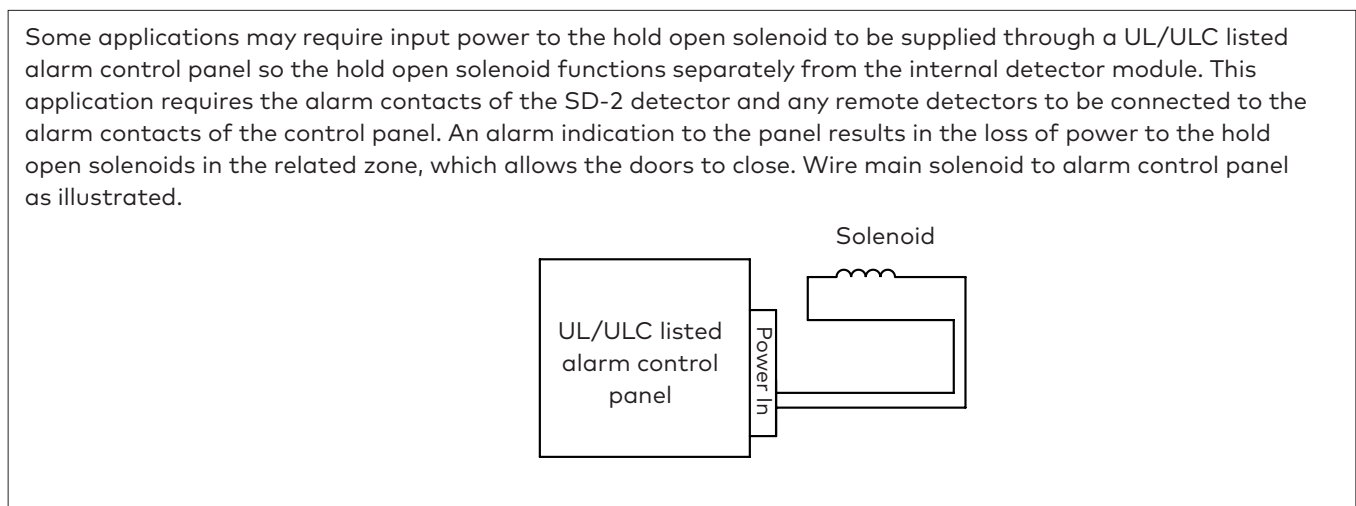

4.10 SD-2 detector interconnection

Fig.17

- Up to (5) SD-2 detectors, with or without connection to an auxiliary unit or remote area detector may be interconnected. This limitation applies only to interconnected units and assumes a power supply large enough to handle this load if the power supply is common to all units interconnected. Separate power supplies may be used for each SD-2 detector while permitting the units to be interconnected.
- For units without connection to remote detectors, connect terminal #15 (+) between the units to be interconnected. Connect terminal #4 (-) between the units to provide a common for the interconnection. Additional units are wired in the same manner as unit #2 but no more than five (5) units can be interconnected.

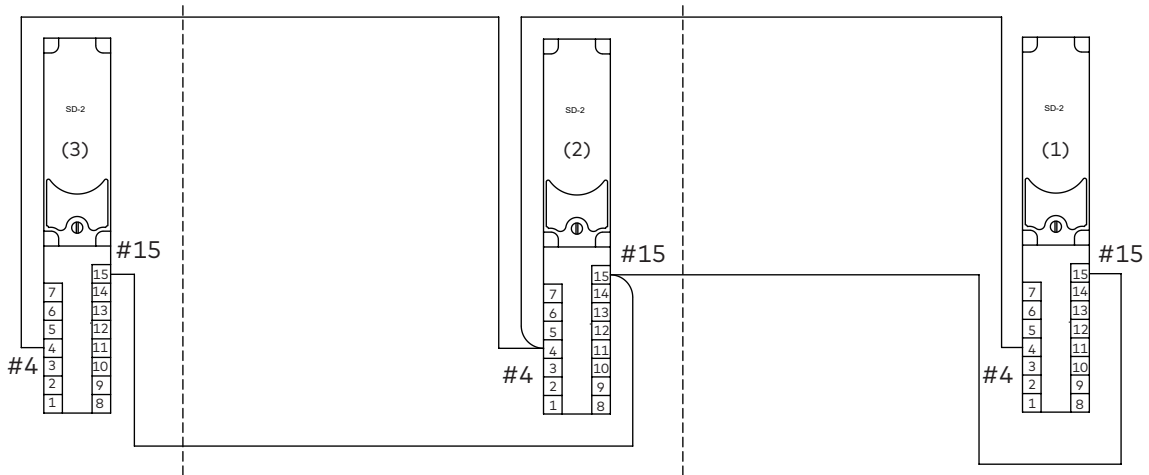

- For units used in conjunction with remote area detectors, complete wiring connections as illustrated below. Heed caution note in SD-2 DETECTOR TO REMOTE AREA DETECTOR section of instruction sheet. Additional units are wired in the same manner as unit #2 but no more than five (5) units can be interconnected. Installations using a combination of SD-2 detector modules with or without remote area detectors can be wired accordingly by substituting the wiring diagram from unit 1, 2, or 3 in step 2 above, for unit 1, 2, or 3 below. The vertical dashed lines indicate where one (1) diagram would be exchanged for another.

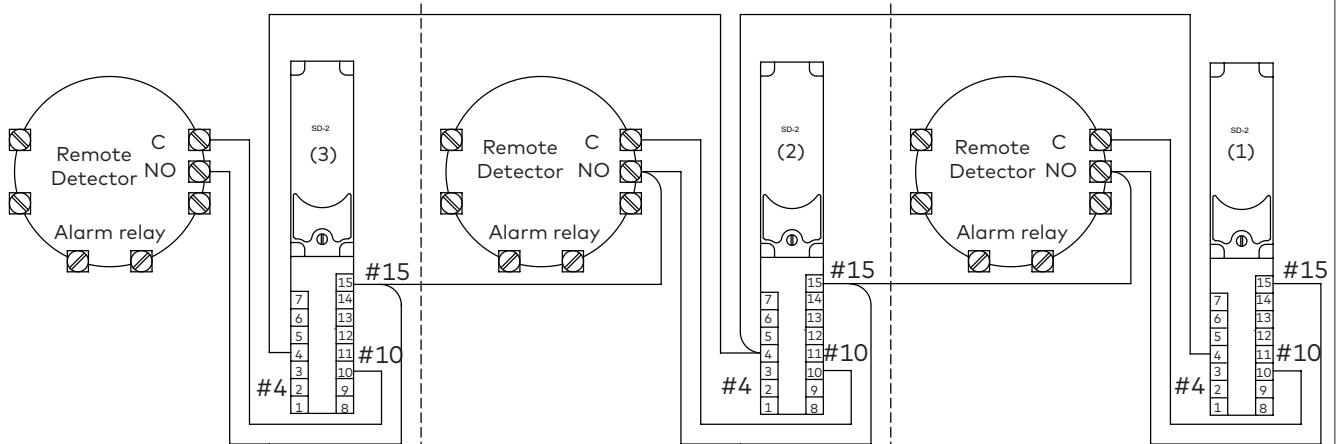

4.11 SD-2 detector to remote area detector

Fig.18

A remote open area detector can only be connected to a unit whose trouble relay contacts (#5 & #13) are connected in a circuit for the purpose of obtaining an audible trouble signal in the event of a circuit fault. In the event that the unit is used for releasing service only, the trouble contacts are connected to the trouble circuit of a UL/ULC listed alarm control panel. This condition is satisfied by the four (4) and six (6) wire supervisory connections in the alarm initiation wiring section. Perform wiring connections as illustrated below. NOTE: The SD-2 is wired as the E.O.L. (end of line) device for the remote detector. Therefore, it must act as the last item in the loop.

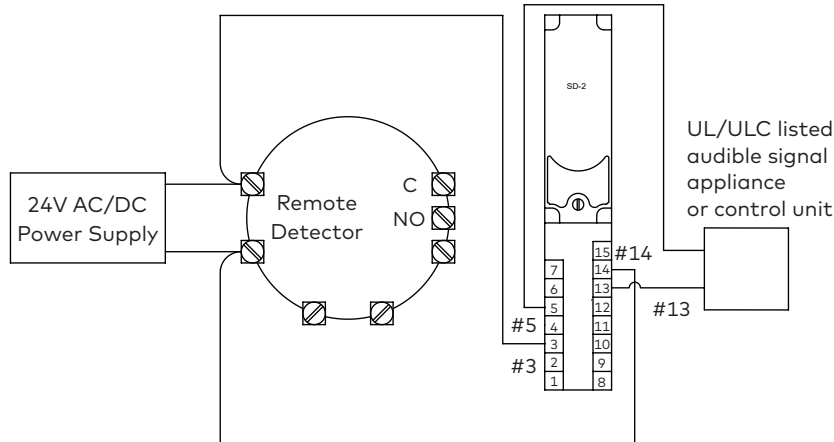

4.12 SD-2 detector to audible signal appliance

Fig.19

1. Connect terminals #5 & #13 of a singular unit directly to a UL/ULC listed audible signal appliance or alarm control panel.

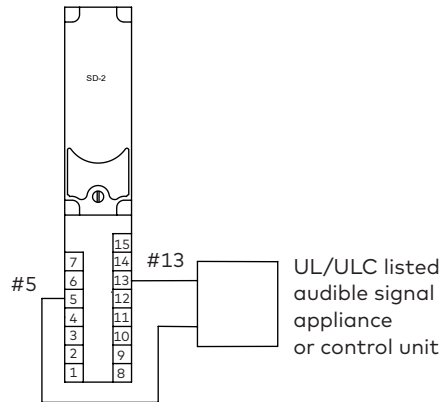

2. Installations with multiple units in a run must be connected to a UL/ULC listed audible signal appliance or alarm control panel as illustrated below.

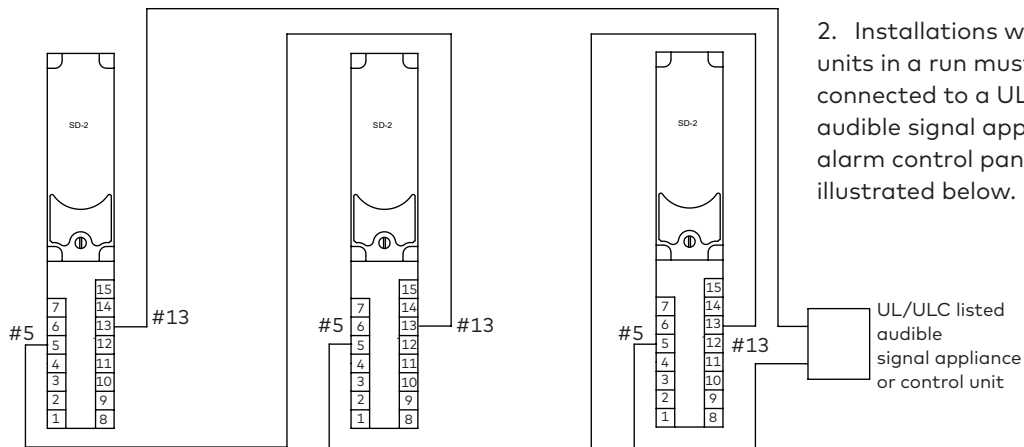

4.13 SD-2 detector to remote alarm indicator lamp

Fig.20

Connect the positive wire of the remote alarm indicator lamp to terminal #8 of the detector module. Connect the negative terminal of the indicator lamp to terminal #7 of the SD-2 detector.

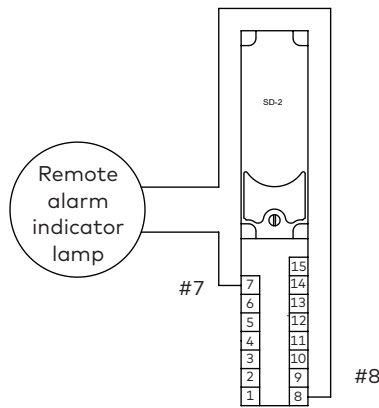

4.14 Alarm initiation wiring 4 wire style B (Class B) & 6 style D (Class A)*

Fig.21

1. Make all connections as outlined previously for all units required by the job specifications.
2. Make all signal initiating connections as illustrated in the appropriate figure below. Note wiring differences for units with remote detectors vs. units without remote detectors. Dashed lines to return loop represent wires required for six (6) wire applications. These wires are omitted in four (4) wire applications.
3. Connections to only one (1) SD-2 are shown below.

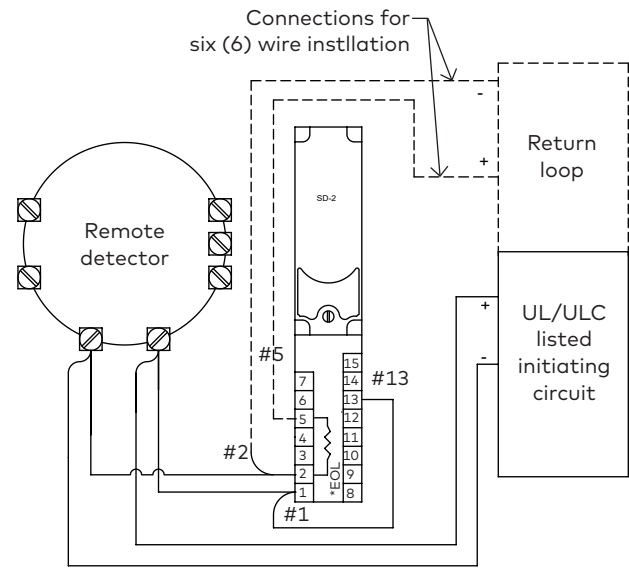
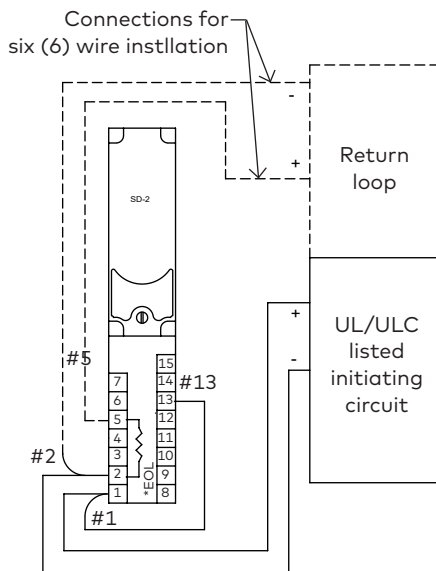

CONTINUED ON NEXT PAGE

* EOL used in 4 wire applications only

Fig.22

4. Connections for two (2) SD-2 detectors would consist of detector (1) in figure below connected to detector (3) in the same manner as it is shown connected to detector (2). Detector (2) would be deleted.
5. More than three (3) SD-2 detectors are connected by inserting additional units with connections as shown for unit 2. The last unit in the run must be connected in the same manner as unit 3.

* EOL used in 4 wire applications only

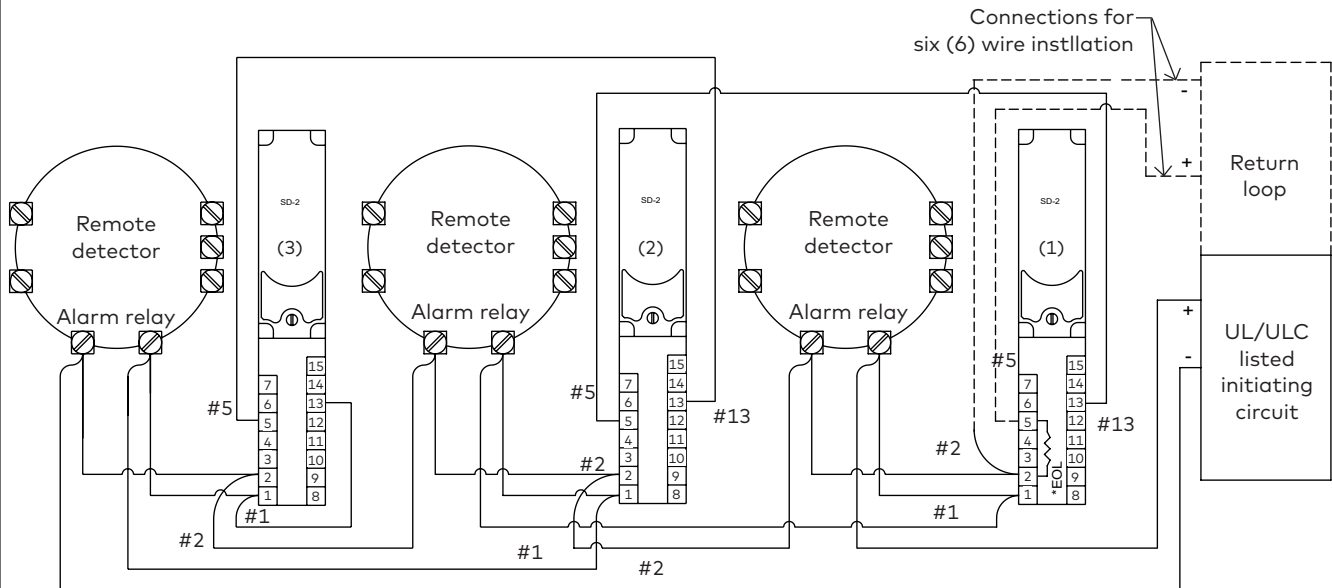
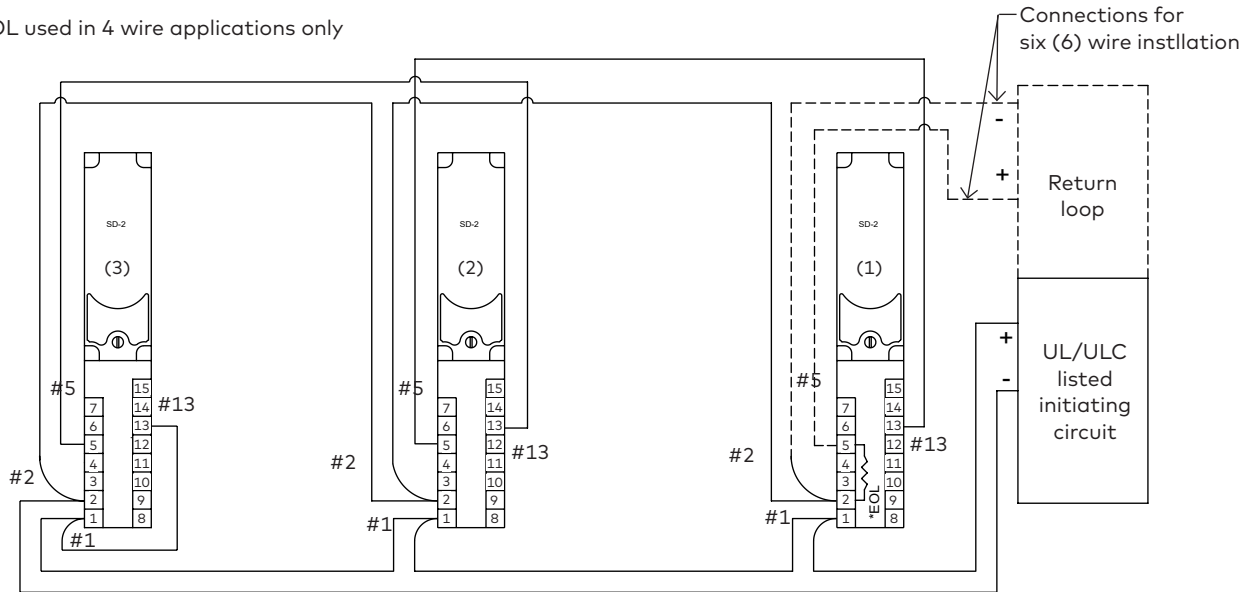

6. In four (4) wire installations, it is the responsibility of the installer to supply and connect the E.O.L. resistor specified by the fire alarm control panel used. The E.O.L. resistor is only installed in the first unit of the run as illustrated.

5 Final set up

5.1 Detector sensitivity test (ULC required only)

Fig.23

Voltage output terminals are provided to measure the sensitivity of the smoke detector. With power applied to the detector, connect a volt meter to the two test terminals. The normal range is between 1.27 - 3.38 VDC.

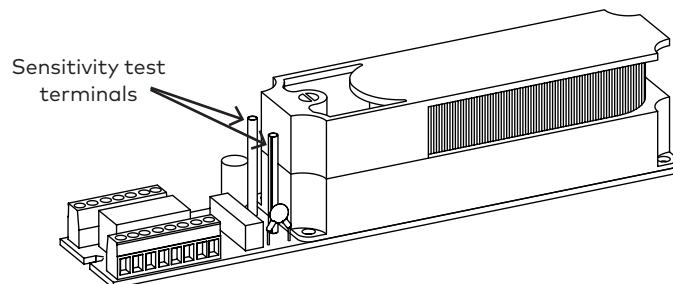

5.2 Check connections

Fig.24

After installation is completed, check all connections. The LED will blink every seven (7) to ten (10) seconds to indicate the unit is operating properly.

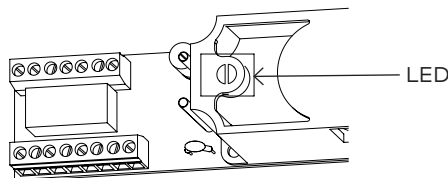

5.3 Engage hold open

Fig.25

Open door so slide shoe engages with hold open assembly.

To test the detector, insert a small screwdriver into the slot in the light pipe of the detector. Turn counter-clockwise and hold for 10 seconds. The LED should remain continually red and allow the door to close.

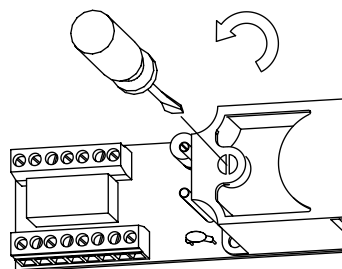

5.4 Reset detector

Fig.26

Turn light pipe clockwise to reset detector. The LED will go off. Turn the light pipe to the normal position and the unit will resume blinking every second (7) to ten (1) seconds to indicate that it is reset and functioning properly.

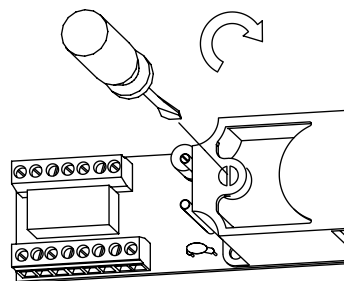

5.5 Unit testing

Fig.27

IMPORTANT: THE UNIT MUST BE TESTED AFTER THE INSTALLATION, BY THE END USER, TO ASSURE THAT THE DOOR CLOSER UNITS FUNCTION PROPERLY WHEN THE ALARM SYSTEM IS ACTIVATED. THE ENTIRE SYSTEM MUST ALSO BE TESTED PERIODICALLY AFTER THE INITIAL INSTALLATION TEST, IN CONJUNCTION WITH THE TESTING OF THE FIRE ALARM SYSTEM. THE END USER IS ALSO RESPONSIBLE FOR THE ADJUSTMENTS AND MAINTENANCE TO RETAIN THE SYSTEM IN WORKING ORDER.

5.6 Install covers

Fig.28

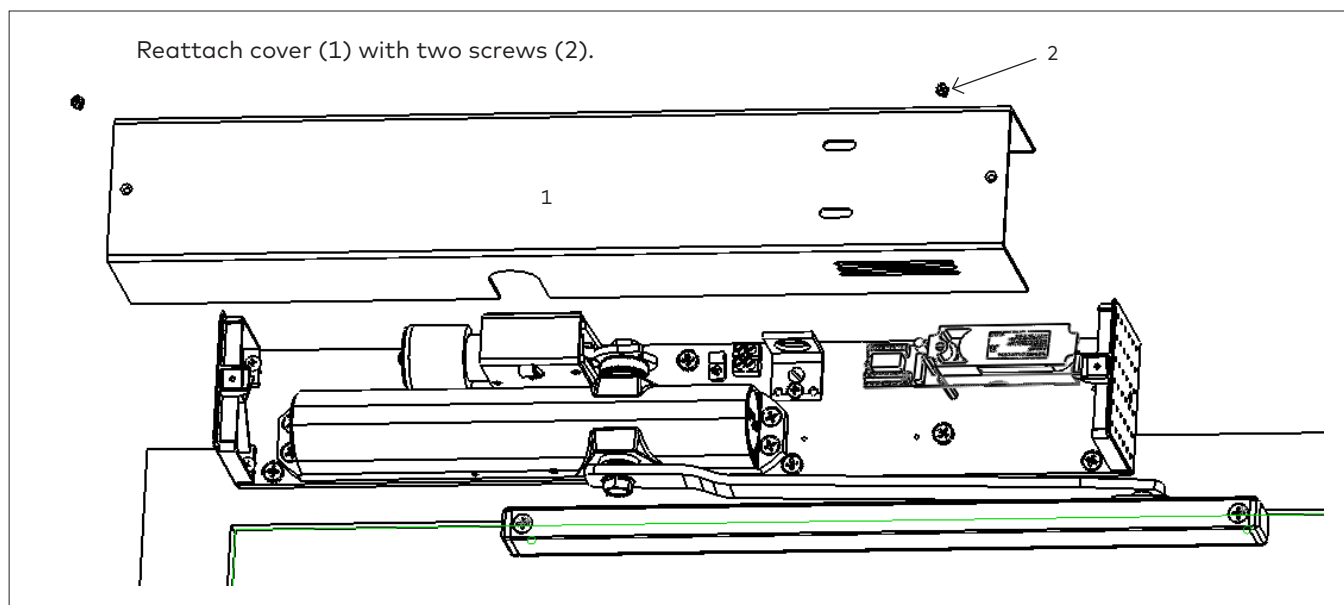

6 Maintenance

6.1 Maintaining the detector

Fig.29

The SD-2 detector has been designed to be as maintenance-free as possible. Normal air-borne dust, however, can accumulate in the detector sensing chamber and cause it to become more sensitive. All detectors must be tested and cleaned at least once a year. Detectors in dusty environments must be tested and cleaned more often. Detectors must also be tested and cleaned immediately after a fire. Failure to maintain detectors may result in needless false alarms.

6.2 Measure and record test voltage

Fig.30

Measure and record test voltage at test points RP1 & RP2. If the product is operating normally, and was cleaned effectively, the test voltage will be less than the voltage recorded earlier (typical voltage for a clean device is 1.27-3.38 VDC).

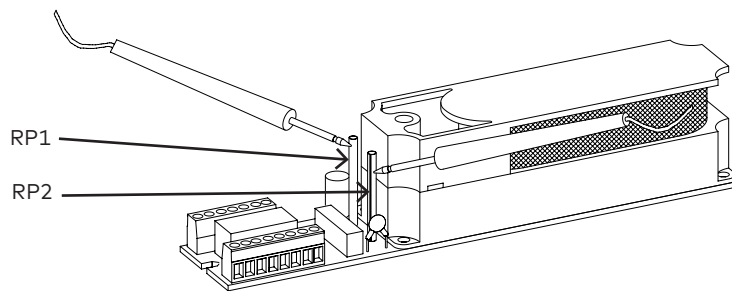

6.3 Vacuum detector

Fig.31

1. First, vacuum or blow off any loose debris on outside of cover. Then, remove the detector cover and screen assembly by rotating a flat screwdriver in slot (both sides) and pulling it straight up. Cover may be difficult to remove the first time.

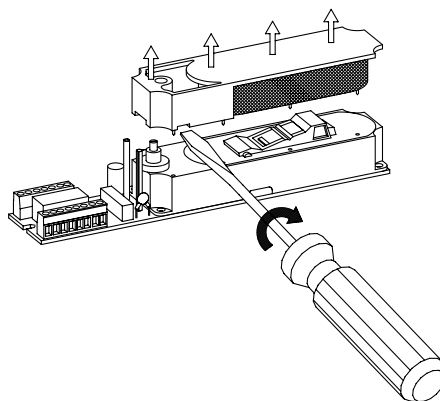

2. Vacuum all areas illustrated below, and then blow off same areas with compressed air. Before reassembling the detector, be sure all parts are free of debris.

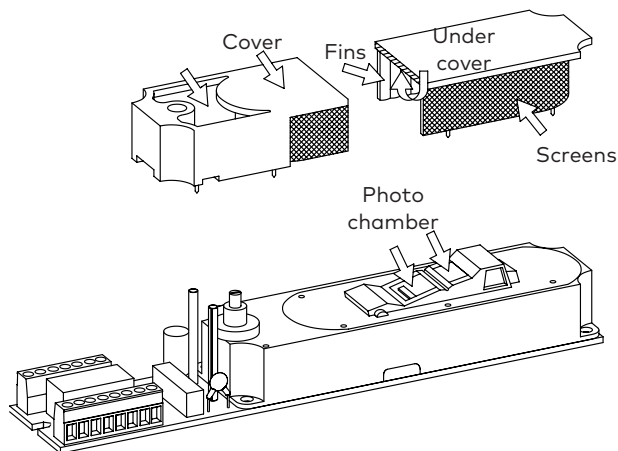

3. Replace cover and screen assembly.
4. Measure and record test voltage at test points RP1 & RP2. If the product is operating normally, and was cleaning effectively, the test voltage will be less than the voltage recorded earlier. (Typically voltage for a clean device is .9 - 1.58 VDC).

6.4 Testing (continued)

Fig.32

- Point the Smoke Detector Tester tube at the detector and release a burst of aerosol by depressing the nozzle for 1 second. Give the detector sufficient time to respond. This may be up to 20 seconds.
- If the detector is in an area where air velocities exceed 100 feet/minute, the detector may not alarm on the first try. This could be due to the signal processing feature of the detector. Signal processing is a feature that adds a time delay to each detector which effectively increases its stability. If this is the case, spray in repeated bursts of 1 second at approximately 5 to 10 second intervals. The total number of sprays should not exceed five (5). If the detector does not alarm after 5 consecutive sprays, it will be necessary to generate larger volumes of smoke to overcome the air flow dilution factor. This can be accomplished by burning paper or fabric in a metal can.
- dormakaba accepts the use of Home Safeguard Smoke Detector Tester (Models 1H and 25S) if, and only if, it is used:
 1. with the Model 1490 Accessory.
 2. with the new formula aerosol as identified by a date code, located on the bottom of the can, of 1990 or later. (This date code can be read as first numeral = last digit of year so that a B9xxx = 2009 and B0xxx = 2010.)
 3. in accordance with the instructions stated above. If the preceding requirements are not met, the use of Smoke Detector Tester is unacceptable and dormakaba cannot guarantee the proper operation of detectors that have been subjected to this product.
- Alternative methods of generating smoke/ aerosol such as the Gemini 501 Smoke Generator Machine may be used to cause alarm at the detector's installed location. Set the generator to represent a 4%/ft to 5%/ft obscuration as described in the Gemini 501 Manual and apply aerosol until the unit alarms. If the Gemini unit is not available, cigarette, punk, or cotton wick are also acceptable means of generating smoke to test this detector.
- Aerosol testing is only a "go - no go" test and is not an acceptable means to determine the smoke detector's sensitivity. See NFPA 72E.
- HOME SAFEGUARD INDUSTRIES 800-822-5676 FAX (847) 427-8343 107 Garlich Drive, Elk Grove, IL 60007

