



# BTS 60TT

# BTS 60TT Floor Spring

## – compact and reliable solution for standard doors

The smallest floor spring from dormakaba, BTS 60TT is developed and made by dormakaba as an economic solution for standard, light use double action doors with a width up to 950mm or a maximum door weight of 85kg. Embodying dormakaba **TwinTec** technology and **SafeForce** valve, BTS 60TT provides a good balance of compact size, strong closing force and enhanced safety.

BTS 60TT is available with various accessories options for glass doors, profile doors and timber doors.

Technical Data		BTS 60TT
Spring strength	Size	3
Standard doors <sup>1)2)</sup>	≤ 950mm	●
Max. door weight in kg		85
Closing speed variable by valve adjustment	120° - 20° 20° - 0°	●
Hold-open point	90°	○
Weight in kg approx.		3.4
Dimension in mm	Length	221
	Width	90
	Height	50

● Yes ○ Option

<sup>1)</sup> For applications involving particularly high or heavy doors, and doors which have to close against wind or draught conditions, the next larger closer size or the dormakaba BTS 80 should be selected.

<sup>2)</sup> Max. opening 120°. Door stop necessary for doors which can open further than 120°.

## Benefits

### Compact size: less work, more savings

BTS 60TT is the smallest floor spring from dormakaba which measures only 221mm x 90mm x 50mm. It saves your time and labor costs, as less flooring work on site is required. It also saves transportation and warehousing costs, as now you can store more with less space.



How small is BTS 60TT compared to others?

BTS 60TT is the smallest floor spring from dormakaba. Its length is equivalent to 2.6 business cards.

### TwinTec: more power with smaller body

TwinTec technology is an innovation from dormakaba that enables a stronger closing power with a smaller body. Its dual piston design provides a strong closing force for up to 950mm door width or 85kg door weight.

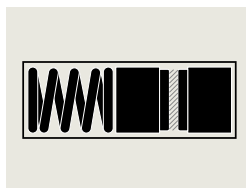

What is TwinTec technology?

TwinTec is the dormakaba dual-piston design for BTS 60TT floor spring to provide a strong and reliable closing force with a compact body.

### SafeForce: reduced risk of injuries

SafeForce is a safety valve that reduces risk of injuries caused by glass breakage when door is closed by strong wind or sudden slamming. Like the airbag of automobiles, SafeForce valve provides extra safety protection from accidental closing forces.

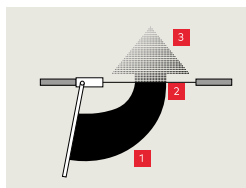

How does SafeForce Work?

**1** Accidental closing by strong wind or extreme force

**2** SafeForce valve provides a safe release of the pressure

**3** Lower risk of injuries from glass breakage or over-swing

### Assurance of dormakaba quality:

BTS 60TT is developed and manufactured by dormakaba. This size 3 floor spring stands stringent test for consistent performance.



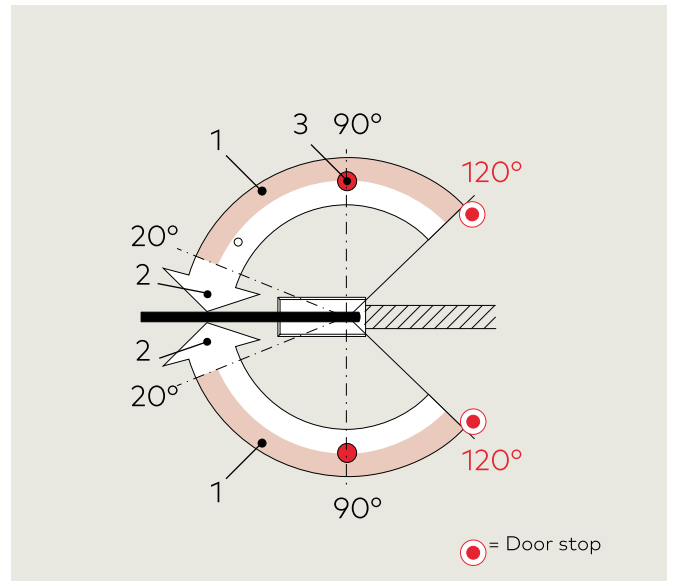
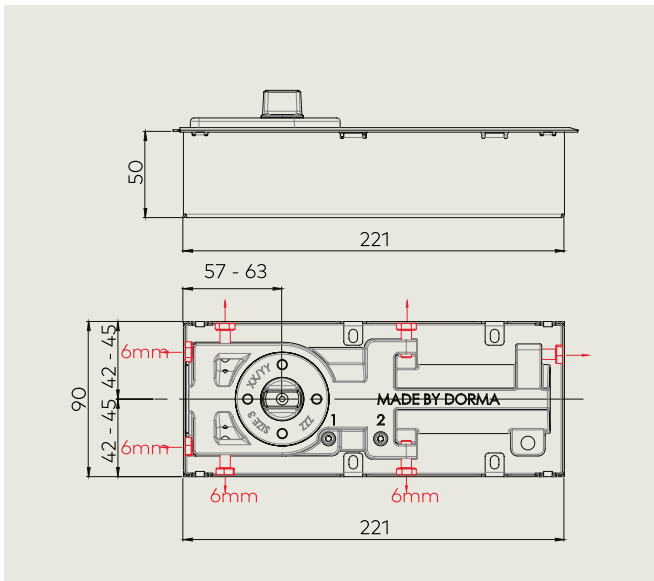

**Measurements**

**Standard and Optional Functions**

**Closing ranges**

The floor spring has two controlled closing ranges:  
 Valve 1: 120° - 20°  
 Valve 2: 20° - 0°

1. First adjusting closing range (120° - 20°)
2. Second adjusting closing range (20° - 0°)
3. Hold open at 90° (for hold-option version only)

**Hold-open**

With the hold-open integrated, the door can be held at an angle of 90°.

## Solution for Frameless Glass Door

**With GD Patch Fittings**

- for 12mm toughened glass
- for door weight up to 85kg
- only for 65mm pivot point

Finish:

satin stainless steel

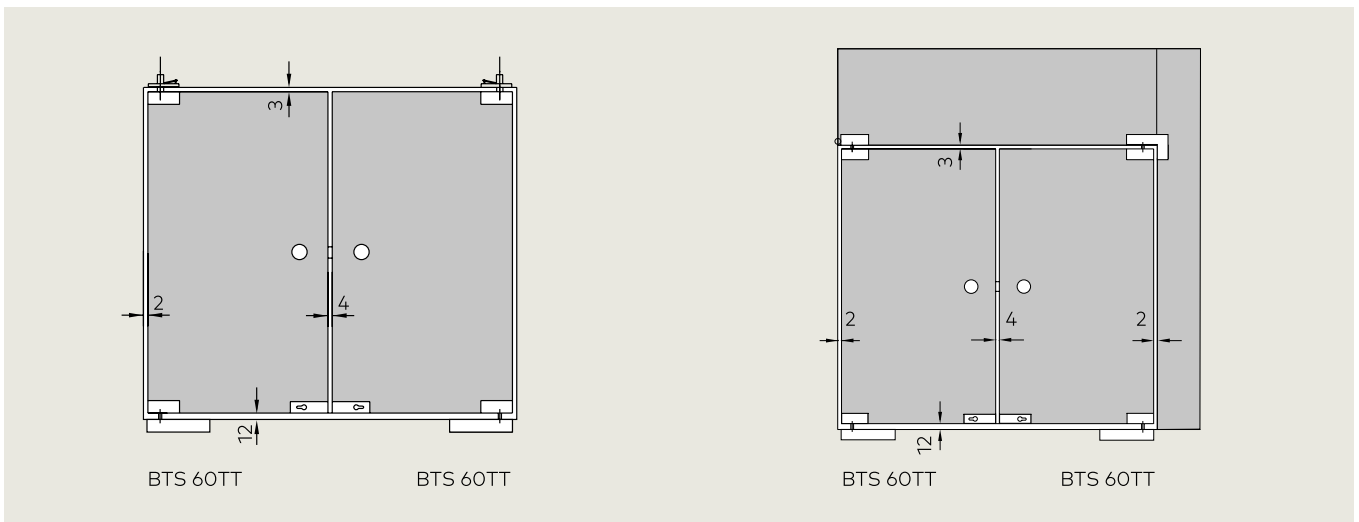

# Glass Preparation

## GD PT10

Bottom Patch Fitting

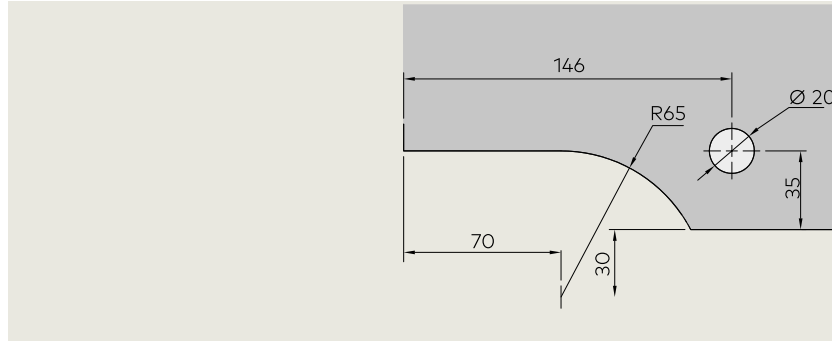

## GD PT20

Top Patch Fitting

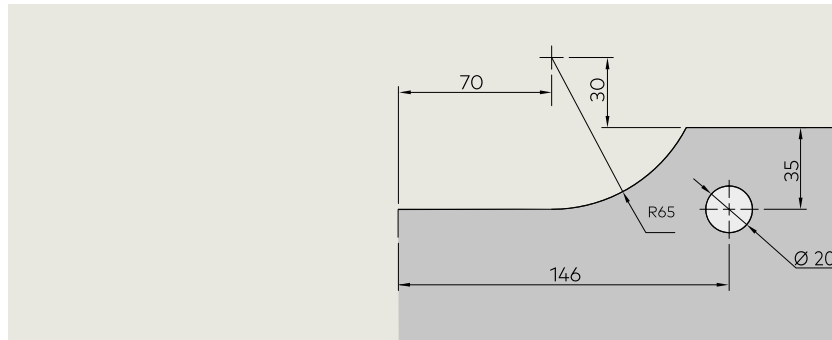

## GD PT30

Over Panel Patch Fitting

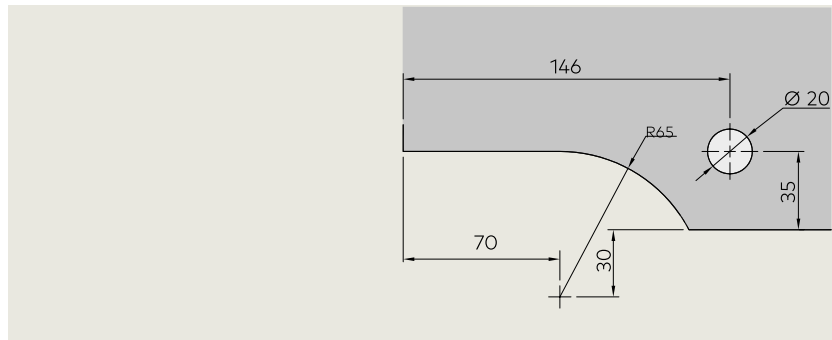

## GD PT40

Over Panel and Sidelight Patch Fitting

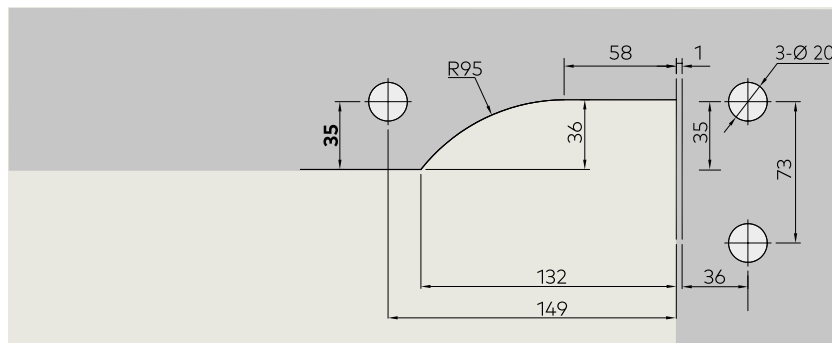

## GD US10

Corner Lock

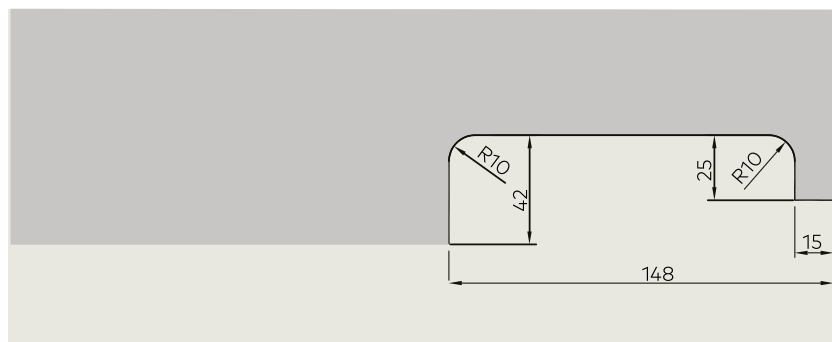

# Solution for Timber and Profile Door

With Door Strap and Top Center

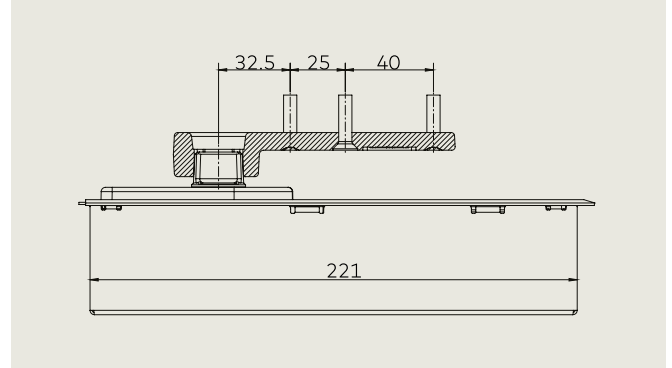
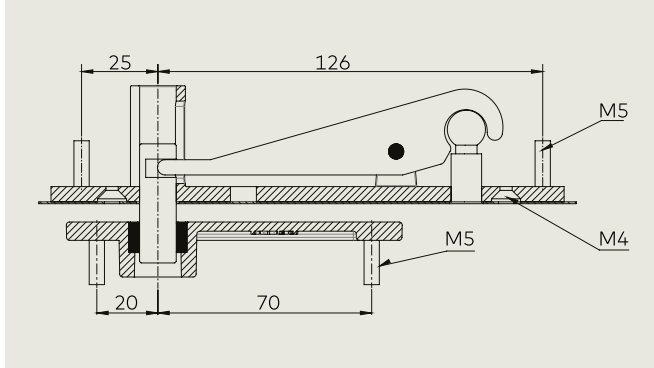
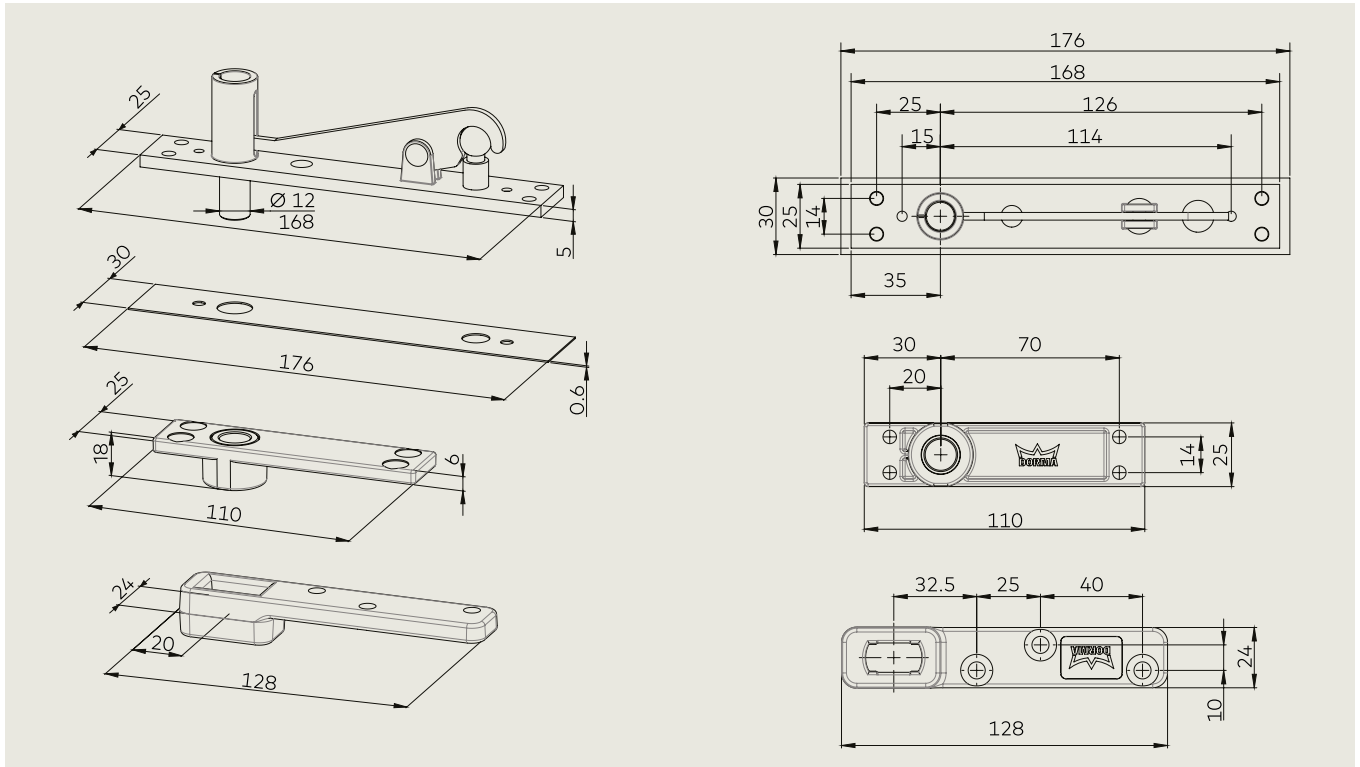

## BTS 60TT Range of Equipment

Description	Article No.
BTS 60TT (Size3 HO) + Door strap & Top center (AF)	105021122
BTS 60TT (Size3 HO) + GD PT10/PT20/PT24 (SSS) (AF)	105021123
BTS 60TT (Size3 HO) + GD PT10/PT20/PT24/US10 (SSS for 12mm glass) (AF)	105021124
BTS 60TT (Size3 HO) + GD PT10/PT20/PT24/US10 (SSS for 12mm glass) (AF)	105021125
BTS 60TT (Size3 NHO) + Door strap & Top center (AF)	105521122
BTS 60TT (Size3 NHO) + GD PT10/PT20/PT24 (SSS) (AF)	105521123
BTS 60TT (Size3 NHO) + GD PT10/PT20/PT24/US10 (SSS) (AF)	105521124
GD PT30 (SSS, for 12mm glass)	6817170
GD PT40 (SSS, for 12mm glass)	6817171

HO = Hold Open; NHO = Non Hold Open; SSS = Satin Stainless Steel; AF = Anti-fake sticker

dormakaba Singapore  
31 Gul Lane  
Tel: +65 6268 7633

dormakaba Malaysia  
(Malaysia/Brunei)  
Taman Perindustrian Tiong Nam  
Tel: +603 5523 5015

Temasya Industrial Park  
Tel: +603 5569 8188

PT dormakaba Access Indonesia  
Tel: +62 21 2930 3762

dormakaba Philippines  
Tel: +63 2 893 4077

dormakaba Thailand  
(Thailand/Cambodia/Myanmar/Laos)  
Tel: +662 236 4994

dormakaba Vietnam Rep Office  
Tel: +84 8 62 998 272

