

# Argus Sensor Barriers



# Elegant Argus Sensor Barriers

## Easy to use, Inviting, Unique

The units in the Argus product range consist of a sensor-controlled passage with automatic door elements in various versions. They provide for convenient contactless passage, even with bags or luggage.

### **Slender Argus HSB (Half-height sensor barriers)**

Tried-and-tested HSB sensor barriers are equipped with door leaves and can be individually customised thanks to the wide range of materials and finishes. You can choose between a stainless steel housing or transparent side walls – matching the design of the entrance area. Moreover the sensor barriers are available in three different lengths – depending on the sensor system used and the level of security desired.



# Advantages of Argus Sensor Barriers

The modular combination of personal safety, throughput rate and design enables entrances to be customised as required.

## HSB Sensor Barriers

- Comfortable passage, even with bags or luggage
- No contact with the door leaves
- High through put rate along with high level of personal safety
- Different security levels for diverse security demands
- Versatile transparent designs
- Modular system with basic and extension units for multi-passage installations
- Door wings always open in direction of passage
- Automatic sneak-by guard (note security level)
- Acoustic alarm when used without authorisation
- Child detection (note security level)
- Special 900 mm width available – suitable for disabled users



Additional versions with a larger passage width for sensor barriers or with automatic swing doors in matching design for sensor gates offer a good solution for disabled access.



# The ideal solution for any entrance



**01**  
Sensor barriers stylishly integrated into timeless interiors

**02**  
Sensor barriers with extension units

**03**  
Display with green and red signals shows clearly if the way is barred or free





**For convenient entry into:**

- Office and administrative buildings
- Ministries and government buildings
- Banks and financial institutions
- Airports
- Industrial buildings
- Schools and universities

**HSB Sensor Barriers**

Throughput rate = up to 30 per minute

Security level = ●●●○○

Comfort = ●●●●●

Staff supervision = yes

# Argus Sensor Barriers



<b>Standard units</b>	<b>HSB-E11</b>	
<b>Construction</b>	Interlock height	945
	Interlock length	1290
	Passage width	650
	Total width	1070
	Housing, base columns, guiding elements	AISI 304 Ø 60 mm stainless steel tube with 10 mm toughened safety glass panel and AISI 304 stainless steel handrail with integrated sensor system.
	Barrier elements	Two door leaves made of transparent polycarbonate, upper edge 900 mm.
		Swinging area monitored by separation sensors.
<b>Finish</b>	Stainless steel satin finish.	
<b>Function</b>	Type 2 *	
	Drives	Integrated in the swing tube.
		Security level 0. Passage area monitored by simple sensor system with a short installation length (simple level of single passage monitoring in both directions).
	Operating modes	Closed.**
<b>Electrical components</b>	Control system and power supply integrated in the unit.	
	Power supply	100 - 240 VAC, 50/60 Hz, 368 VA.
	Standby power consumption	17 VA.
	Standard adjustment in event of power failure	Door leaves move freely.
<b>Installation</b>	Dowelled on finished floor level, FFL.	
	Not suitable for outdoor installation.	
<b>Protection classes</b>	Housing IP32, components conducting supply voltage IP42.	

\* Type 2: power-assisted motion; two servo-positioning drives/ electrically controlled in both directions.

\*\*Basic position open "day operation": the door leaves are closed automatically if authorisation is not granted for passage.

Basic position closed "night-operation": the door leaves open automatically in the direction of passage and then close again if authorisation is granted.

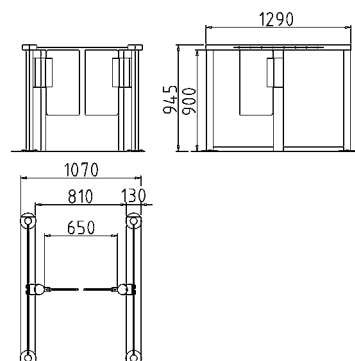

All dimensions in mm





HSB-E07	HSB-E08
945	945
1660	2010
650	650
1070	1070
AISI 304 Ø 60 mm stainless steel tube with 10 mm toughened safety glass panel and AISI 304 stainless steel handrail with integrated sensor system.	AISI 304 Ø 60 mm stainless steel tube with 10 mm toughened safety glass panel and AISI 304 stainless steel handrail as well as horizontal and vertical sensors mounted on the guiding elements.
Two door leaves made of transparent polycarbonate, upper edge 900 mm.	Two door leaves made of transparent polycarbonate, upper edge 900 mm.
Swinging area monitored by separation sensors.	Swinging area monitored by separation sensors.
Stainless steel satin finish.	Stainless steel satin finish.
Type 2 *	Type 2 *
Integrated in the swing tube.	Integrated in the swing tube.
Security level 1. Passage area monitored by basic sensor system with a compact installation length (basic level of single passage monitoring in both directions).	Security level 2. Passage area monitored by enhanced sensor system with an optimised installation length and arrangement (increased level of single passage monitoring in both directions). Integrated sneak-by guard, detection of children and trolley cases.
Open or closed.**	Open or closed.**
Control system and power supply integrated in the unit.	Control system and power supply integrated in the unit.
100 - 240 VAC, 50/60 Hz, 368 VA.	100 - 240 VAC, 50/60 Hz, 368 VA.
17 VA.	17 VA.
Door leaves move freely.	Door leaves move freely.
Dowelled on finished floor level, FFL.	Dowelled on finished floor level, FFL.
Not suitable for outdoor installation.	Not suitable for outdoor installation.
Housing IP32, components conducting supply voltage IP42.	Housing IP32, components conducting supply voltage IP42.

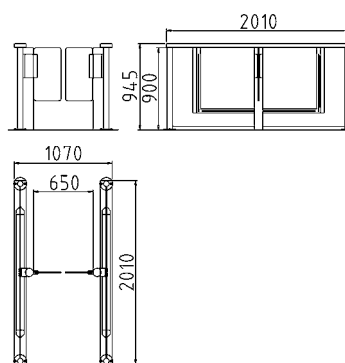
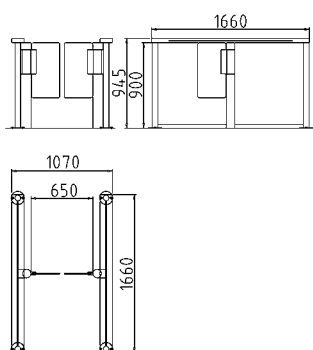

# Argus Sensor Barriers



<b>Standard units</b>	<b>HSB-E12</b>
<b>Construction</b>	
Interlock height	1600
Interlock length	2050
Passage width	650
Total width	1050
Housing, base columns, guiding elements	AISI 304 stainless steel with satin finish.
Barrier elements	Two door leaves made of transparent polycarbonate, upper edge 1600 mm. Swinging area monitored by separation sensors.
<b>Finish</b>	Stainless steel satin finish.
<b>Function</b>	Type 2 *
Drives	Integrated in the swing tube.
Operating modes	Security level 2. Passage area monitored by enhanced sensor system with an optimised installation length and arrangement (increased level of single passage monitoring in both directions). Integrated sneak-by guard, detection of children and trolley cases. Open or closed.**
<b>Electrical components</b>	Control system and power supply integrated in the unit.
Power supply	100 - 240 VAC, 50/60 Hz, 368 VA.
Standby power consumption	17 VA.
Standard adjustment in event of power failure	Door leaves move freely.
<b>Installation</b>	Dowelled on finished floor level, FFL. Not suitable for outdoor installation.
<b>Protection classes</b>	Housing IP43, components conducting supply voltage IP43.

\* Type 2: power-assisted motion; two servo-positioning drives/ electrically controlled in both directions.

\*\*Basic position open "day operation": the door leaves are closed automatically if authorisation is not granted for passage. Basic position closed "night operation": the door leaves open automatically in the direction of passage and then close again if authorisation is granted.

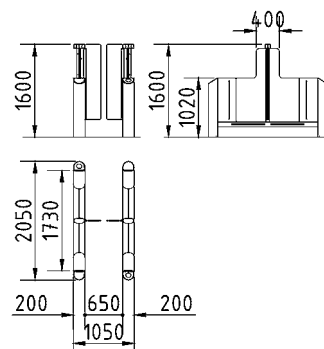

All dimensions in mm

# Options (depending on unit type)

	HSB-E11	HSB-E07	HSB-E08	HSB-E12
<b>Construction</b>				
Cover plate made of wood.			•	
Passage width increased to 900 mm for disabled users and transit of goods.	•	•	•	•
Angular base columns.	•	•	•	
Door leaf extends to a height of 1200 mm instead of 900 mm.			•	
Door leaf extends to a height of 1800 mm instead of 1600 mm.				•
<b>Function</b>				
Emergency and escape route modules with emergency push button, additional emergency push button available.	•	•	•	•
<b>Electrical equipment</b>				
Installation preparation on flat surface for on-site components or using mounting plate for surface installation.	•	•	•	•
Plastic cover plates instead of stainless steel plate for installation of antennas provided by customer.				•
Push button for manual single release.	•	•	•	•
Operating panel and frame or surface mount housing.	•	•	•	•
Additional circuit boards for expanding existing inputs and outputs.	•	•	•	•
Various signal devices.	•	•	•	•
<b>Installation</b>				
Pallet with stainless steel ramp and non-slip rubber covering, height approx. 32 mm.	•	•	•	•
On adjustable mounting plate X = 80 - 180 mm for sub floor level.	•	•	•	•
With cast-in clamping elements and cover rosettes for sub floor level.	•	•	•	



OPL 05 operating panel.

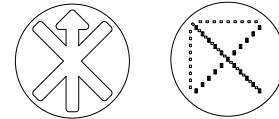

Signal device LED arrow-cross (installed in the housing or in the cover plate of both sides)



Console 1 with plastic adapter in RAL 9006, W/H/D 94/94/65 mm with Ø 65 mm cut-out, fixed to lateral barrier.

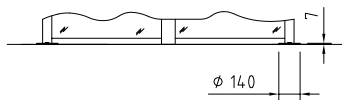

Installation HSB-E07, -E08, -E11 dowelled on finished floor level FFL

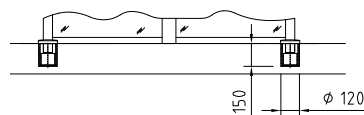

Cast-in with clamping elements

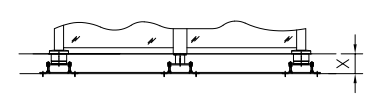

on sub floor level SFL with mounting plates



Installation HSB-E12 dowelled on finished floor level FFL

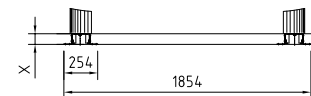

on sub floor level SFL with mounting plates

## Installation diagrams

HSB-E08 examples

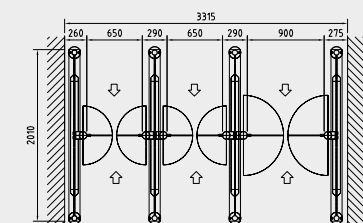
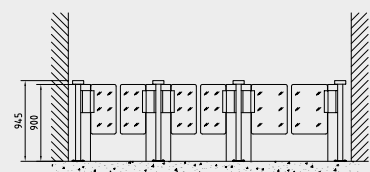
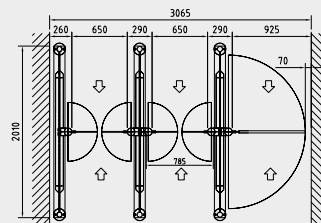
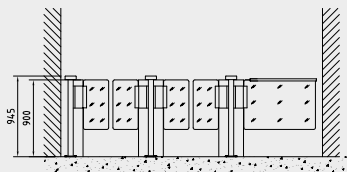

## Our Sustainability Commitment

We are committed to foster a sustainable development along our entire value chain in line with our economic, environmental and social responsibilities toward current and future generations. Sustainability at product level is an important, future-oriented approach in the field of construction. In order to give quantified disclosures of a product's environmental impact through its entire life cycle, dormakaba provides Environmental Product Declarations (EPD), based on holistic life cycle assessments.

[www.dormakaba.com/sustainability](http://www.dormakaba.com/sustainability)



## Our offering

### Access Automation Solutions

Entrance Automation  
Entrance Security



### Access Control Solutions

Electronic Access & Data  
Escape and Rescue Systems  
Lodging Systems



### Access Hardware Solutions

Door Closers  
Architectural Hardware  
Mechanical Key Systems



### Services

Technical Support  
Installation and commissioning  
Maintenance and Repair



WN 05574151532 · EN · 09/23

Subject to change without notice



[dormakaba.com](http://dormakaba.com)

**dormakaba**  
**International Holding AG**  
Hofwissenstrasse 24  
CH-8153 Rümlang  
T +41 44 818 90 11  
[info@dormakaba.com](mailto:info@dormakaba.com)  
**dormakaba.com**