

Mounting Instructions







71111 President / 71113 President A

1. General Information

These mounting instructions are the basis for the approval by ECBS, VdS, A2P (CNPP)- DNV, UL. Installation of the lock to be performed exclusively in accordance with these instructions. Guidelines of the national certification bodies are to be considered and complied with in addition.

- Attention: The lock bolt of version 71113 with option "Not Key Retained" (Optioncode SAB) is not arrested in position "lock open".
- Any variation of the lock or key may result in functional trouble and must better not be done. All claims under guarantee and warranty will expire in this case.
- Prevent the ingress of dirt into the lock.
- Lock fastening: Use of M6 steel socket head cap screws or BSW ¼" steel bolts. The length of engagement must correspond to the applicable standards considering the thickness of the lock of 22 mm.
- Fastening screws: minimum property class 4.8 and maximum property class 8.8.
- Screws to be secured either by lock washer, flat spring, tooth lock washer, fan type lock washer considering the diameter (d1) or to be cemented.
- Screw tightening moment: minimum 5 Nm and maximum 6 Nm.
- The bolt must be floating in installed condition.
- It is recommended, that unauthorized persons have no access to security sensitive parts of the lock, also the door of the safe, where the lock is installed, is open.
- Perfect function of the lock and of any additional connected or triggered systems (e.g. bolt-works) must be warranted and checked by specialists during installation of the lock.
- The lock is designed for installation in secure storage units made of steel. Installation in storage units consisting of other material e.g. plastic is not allowed.
- Lock to be installed covered and so as to prevent opening by boring.

2. Mounting Position

Lock mounting position			
RH version (standard version):		LH version (special version for LH applications):	
Bolt left, keyhole horizontal		Bolt right, keyhole horizontal	
Bolt downwards, keyhole vertical		Bolt downwards, keyhole vertical	
Bolt upwards, keyhole vertical		Bolt upwards, keyhole vertical	

3. Specification Key Guide and Key Hole

- Use of the Kaba Mauer key guide (see Fig. 1) or of the Kaba Mauer key carrier guide (see Fig. 2) is recommended. Considering DIN 2768-mH, the keyhole in the door of the secure storage unit should be dimensioned accordingly (see Fig. 1 or 2).

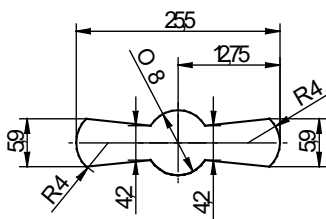

Fig. 1: Key guide 86101

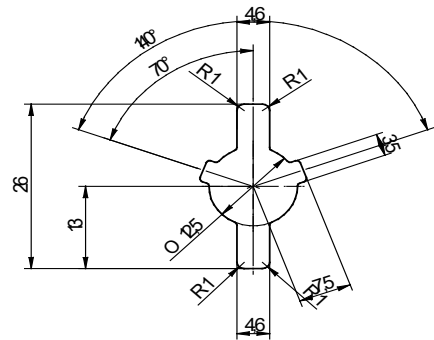

Fig. 2: Key carrier guide 86102

- In cases where the Kaba Mauer key guide or key carrier guide are not used, the maximum cross sectional area of the keyhole in the door of the secure storage unit and/or the lock armour plating may not exceed the dimensions given in Fig. 3 considering DIN 2768-mH. All dimensions deviating from these specifications are to be coordinated separately with the certification bodies (test houses).

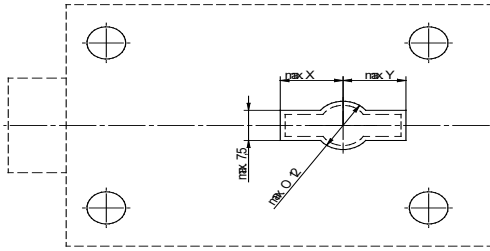

Fig. 3: Max. cross sectional area of keyhole

President A	X (mm)	Y (mm)
71111/13	13.5	12.5

With a minimum distance of 60 mm between the front of the safe door and mounting surface of the lock the following dimensions are allowed:

President A	X (mm)	Y (mm)
71111/13	13.5	13.0

4. Lock Mounting

- For installation and adjustment of the lock on the door, make sure that the key can be inserted into the lock without having to apply force and without jamming. This can be achieved by mounting the lock according to the following pattern of mounting holes (Fig. 4). For further lock dimensions please refer to the Kaba Mauer Catalogue Sheet. Mounting plate 3118000300 may be used as an alternative.

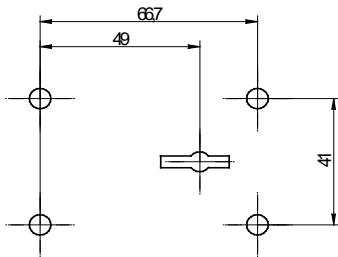

Fig. 4: Fastening hole pattern

- In case of using the bolt switch (Option code RSK) it is important to keep the area clear shown in fig.5 to prevent the damage of the cables and the switch. The cables must not be buckled in the area of the heat shrink tubing. The cables have to be installed that they can not be damaged by moving parts (e.g. from boltwork) or sharp edges

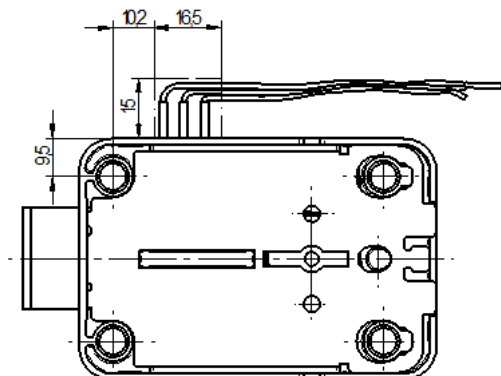

Fig 5: Keep clear area for cables

5. Technical Data

- Lift height of bolt 12 mm
- Bolt in fully extended position: approx. 14 mm
- Bolt width: 25,4 mm; Bolt height: 12,6 mm
- The maximum allowable force acting on the key bolt against the blocking direction, the maximum locking force and the lateral load acting on the bolt, correspond to 1 kN and should not exceed this value. Provision should be made design wise for bolt stoppers on both ends or for a bolt support.
- The actuating turning moment on the key may not exceed 2.5 Nm
- Mounting plate 3118000290 – reinforced by manganese steel – is available at option as a protection against opening by boring.
- Fixing of boltwork: via two bores on the front end (core borehole 3.3 mm) of the bolt head
- Optional fixing of boltwork: two M4 threads (front end) or by means of a drift pin in the bolt head
- The bolt was according to EN1300 with a permanent load of 2,5 N over 10.000 cycles tested. These load should not be exceeded permanently.