

# Quantum™

## RFID RCU/ECU



### Applications

- RCU switch works with electrified locking devices
- Fits into double-gang switch box
- Controls electric locking devices up to 24 volts AC/DC
- Auto latch/unlatch feature eliminates need for manual dogging
- SPDT 5A@30VDC relay with common, normally open and normally closed contact

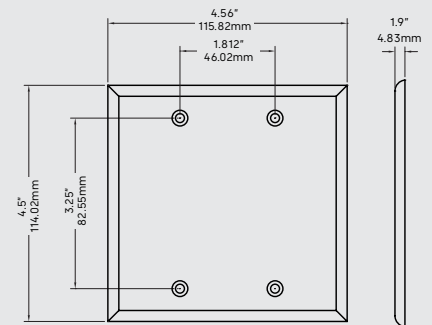

### Overview

The Quantum™ RFID remote control/ elevator control unit (RCU/ECU) is a versatile stand-alone card reader controller. Through the application of contactless smart card technology, this remote control device is designed to work with all electrified access control devices for perimeter doors, concierge floors, common areas, and other secured areas with electrified hardware.

### Mobile access solutions

The reader device is able to operate using the dormakaba Mobile Access Solutions.

### Voltage

- 12-24 AC/DC

### Outside dimensions

- 4.56" W x 4.50" H x 0.75" D

### Finish options

- Bright Brass
- Bright Chrome
- Satin Brass
- Satin Chrome
- Dark Mahogany
- Black
- Satin Nickel

### Access management software

The Quantum RFID RCU/ECU is supported by dormakaba's robust access management software solution that features an array of access control workflows for both guest and staff access. Optionally, choose dormakaba's online access management solution for superior control and monitoring.

### Features

- Ability to easily integrate into any System 6000™ design
- Environmentally sealed contactless smart card reader protects against climate extremes, which is an especially vital feature for common access readers placed in external building and exit device applications
- Optionally equipped with the online transceiver for centralized access control
- LED lights displayed behind high-impact polycarbonate reader lens
- Contactless smart card reader uses industry-standard MIFARE ISO 14443A communication platform and high-security protocol
- USB connectivity to LPI probe
- Keycards are programmed using a contactless encoder
- Contactless communication between the keycard and the reader via RF waves
- Programmable auto latch/unlatch feature eliminates need for manual dogging
- Configurable for normally closed circuits (magnet latches) and normally open circuits (electric strikes)
- Auditable entries/attempts
- Selectable master key access
- Restricts access to guest keys after check-out date

### Specifications

- Voltage: 12-24 VAC or VDC
- SPDT 5A@30VDC relay with common, normally open and normally closed contacts

### Requirements

- Double-gang switch box

### Mobile access options

- BLE ready: upgradable to BLE by BLE module
- BLE enable: end cap with BLE module included, no further upgrades need



© 2024 dormakaba Inc. Information on this sheet is intended for general use only. dormakaba reserves the right to alter designs and specifications without notice or obligation.

**Any questions? We would be happy to advise you.**

Contact us at: 800.999.6213