

ED250

Installation in In-ground Case

Owner's Manual

DL4615-014 – 09-2021

| EN |

dormakaba 

Table of contents

Table of contents	2
1 General information	3
2 To our customers	3
3 What you should know	4
3.1 Distributor information	4
3.2 Program switch panel control modes	5
3.3 Knowing act	5
4 AAADM safety information labels	6
4.1 Safety information label, full energy swing doors (ANSI BHMA A156.10)	6
4.2 Safety information label, low energy swing doors (ANSI BHMA A156.19)	7
5 Daily safety check procedure	8
5.1 Full energy power operated swing door (ANSI/BHMA 156.10)	8
5.2 Low energy power operated swing doors (ANSI/BHMA A156.19)	9
6 General safety related items	10
6.1 Full energy power operated swing doors (ANSI/BHMA 156.10)	10
6.1 Low energy power operated swing doors (ANSI/BHMA 156.19)	11
7 ED100/ED250 door signage	12
7.1 Full energy operator (ANSI/BHMA A156.10)	12
7.2 Low energy operator (ANSI/BHMA 156.19)	13
7.3 Door signage, low energy swing doors (ANSI/BHMA 156.19)	14
7.4 Door signage, full energy single swing doors (ANSI/BHMA A156.10)	15
7.5 Door signage, full energy double swing doors (ANSI/BHMA A156.10)	15
8 ED250 in-ground door threshold	16
8.1 Install door threshold	16

1 General information

1.1 Owner's manual.

This Owner's Manual applies to the ED250 operator packaged in a cement case for in-ground floor installations.

1.2 Manual storage.

This document must be kept in a secure place, and accessible for reference as required. If the door system should be transferred to another facility, insure that this document is transferred as well.

1.3 dormakaba.us website.

Manuals are available for review, download, and printing on dormakaba.us website.

1.4 Dimensions

Unless otherwise specified, all dimensions are given in inches (").

1.5 Symbols used in this manual.



WARNING

This symbol warns of hazards which could result in personal injury or threat to health.

NOTICE

Draws attention to important information presented in this document.

CAUTION

This symbol warns of a potentially unsafe procedure or situation.

1.6 In-ground case and ED 250 operator.

Fig.1.1 In-ground case and ED250 operator

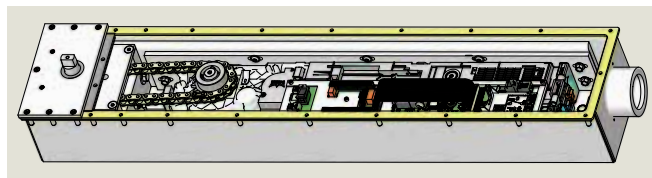

2 To our customers

We are pleased that a dormakaba USA Inc. ED250 in-ground system has been selected for this installation. The system has been designed, tested and built to provide many years of service.

The purpose of this manual is to familiarize you with your ED250 in-ground swing door system.

It is essential that you "know your system" and that you recognize the importance of maintaining your door system in compliance with industry standards for safety.

It is your responsibility as owner and caretaker of the equipment, to inspect the operation of your door system on a daily basis as outlined in Chapter 4, Safety Information Checklist to insure that it is safe for use by your customers and employees.



WARNING

Should the door fail to operate as prescribed in the Safety information checklist or at any other time for any reason, do not attempt to repair or adjust the ED250 swing door system!

Access to the ED250 in-ground system must only be done by dormakaba USA Inc. certified technicians!

Call your local authorized dormakaba USA Inc. distributor for repair. The distributor's AAADM certified technicians are trained to service the ED250 in-ground swing door system using the dormakaba USA Inc. installation manual, and in accordance with ANSI/BHMA safety standards.

2.1 Service availability.

dormakaba USA Inc. has a nationwide network of authorized distributors for sales, installation and service of its products.

2.2 Compliance with industry standards for safety.

Your ED250 in ground swing door system was designed to the latest ANSI/BHMA operating and safety standards. In order to insure the continued safe operation of the door, it is important that:

- Proper decals and labels be applied and maintained on your doors (Chapter 7).
- If decals and labels have been removed, or cannot be read, contact your local authorized dormakaba USA Inc. distributor for replacement decals or labels.

3 What you should know

3.1 Distributor information

3.1.1 dormakaba USA Inc. distributor information.

Be sure that the dormakaba USA Inc. distributor has provided the following information for each door installation:

1. dormakaba USA Inc. ED250 in-ground Owner's Manual.
2. Review of the daily Safety Information Checklist (Chapter 4).
3. Instructions on how to conduct the daily Safety Information checklist by walk through example (Chapter 5).
4. Annual compliance inspection label completion (Chapter 4).
5. Circuit breaker or disconnect location for 115 Vac power to the ED250 in-ground system.
6. ED250 program switch panel location and instructions in its use. (Para. 3.2, 3.3).
7. Discussion of problems that could result from operator being allowed to operate after a malfunction observed.
8. Number to call for service or questions about your system if you are uncertain of any condition or situation.



WARNING

If there are any problems, discontinue door operation immediately and secure the door in a safe manner. Call your local dormakaba USA Inc. distributor for repair.

3.2 Mode switch and Exit Only switch panel

Fig. 3.2.1 Mode switch and Exit Only switch panel

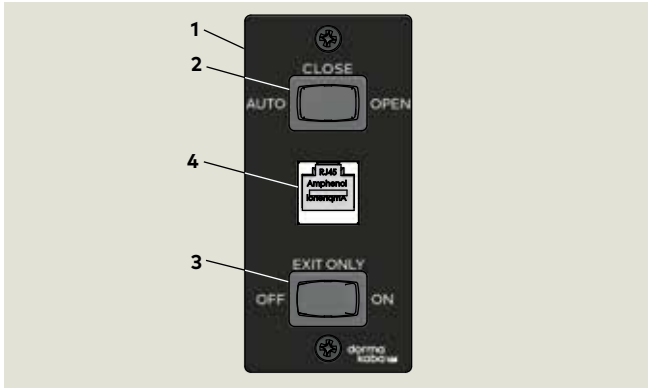

- 1 Mode switch panel
- 2 Mode switch, three position
- 3 Exit only switch, two position
- 4 RJ45 Comm port for service

Fig. 3.2.7 Optional key switch panels



3.2.1 Mode switch positions.

Fig. 3.2.2 Auto

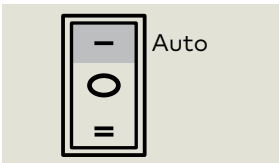

3.2.2 Exit Only switch positions.

Fig. 3.2.5 On

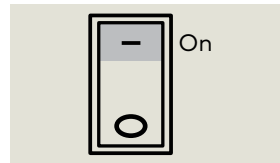

Fig. 3.2.3 Close

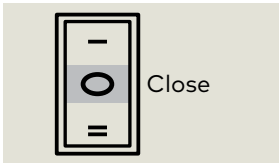

Fig. 3.2.6 Off

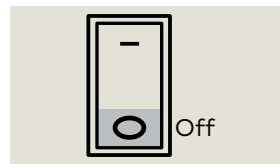
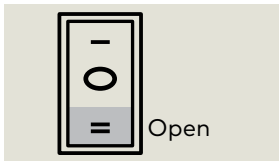

Fig. 3.2.4 Open



3.2.3 Mode switch position descriptions.

Auto

1. Door opens automatically when one of the activators is actuated or triggered.
Door closes on expiration of adjustable hold open time with no activators or actuators triggered.
2. With knowing act device actuation (Para. 3.4.2).
Door will remain at full open position for not less than 5 seconds.
3. With push/pull actuation of door (Para. 7.2).
Door will remain at full open position for not less than 3 seconds.

Close

1. Door will remain closed, or if door is open door will close.

Open

1. Door opens automatically and remains open.

3.2.4 Exit Only switch position descriptions.

On

1. Exterior activation sensor or knowing act device disabled when door fully closed.
 - Only interior activation sensor or knowing act device will enable door opening.

Off

1. Both interior and exterior activation sensors or knowing act devices will enable door opening.

4 AAADM safety information labels

4.1 Safety information label, full energy swing doors (ANSI BHMA A156.10)

4.1.1 Full energy automatic swing door safety information label.

This AAADM label (Fig. 4.1.1) outlines safety checks that should be performed daily on a swing door controlled by an ED250 in ground operator configured for full energy operation (ANSI/BHMA 156.10).

4.1.2 Safety information label location.

Place label in a protected, visible location on door frame, near program switch panel if possible.

4.1.3 Annual compliance section of label.

This section of label is only completed on automatic swing doors that comply with ANSI/BHMA A156.10 standard and pass inspection by an AAADM certified dormakaba USA Inc. technician.

4.1.4 Additional annual compliance inspection labels.

Place additional labels (Fig. 4.1.2) over annual compliance inspection section of safety information label.

Fig. 4.1.1 Full energy safety information label

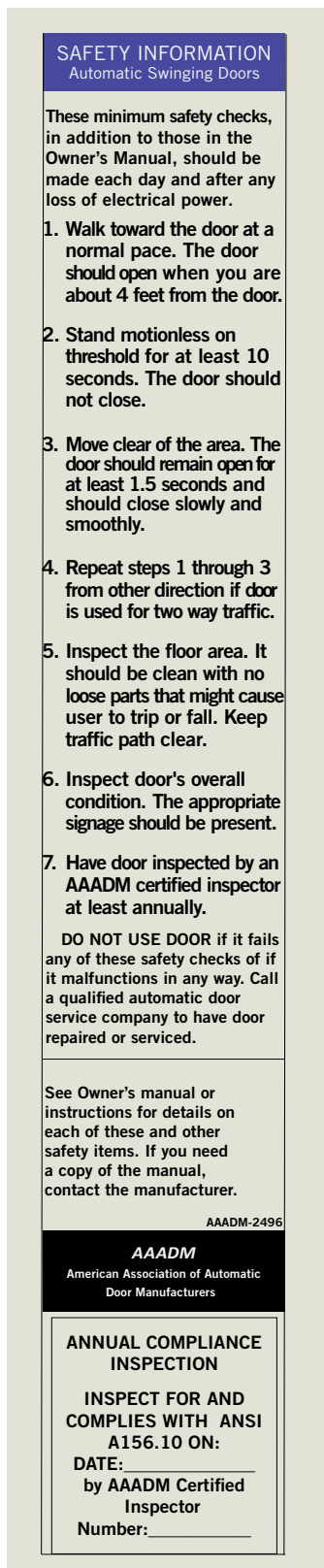
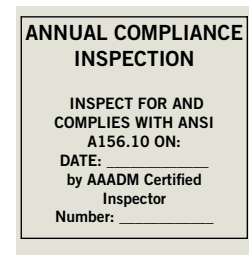

Fig. 4.1.2 Annual compliance label, full energy



4.2 Safety information label, low energy swing doors (ANSI BHMA A156.19)

4.2.1 Low energy swing door safety information label.

This AAADM label (Fig. 4.2.1) outlines safety checks that should be performed daily on a swing door controlled by an ED250 in-ground operator configured for low energy operation (ANSI/BHMA A156.19).

4.2.2 Safety information label location.

Place label in a protected, visible location on door frame, near operator power switch if possible.

4.2.3 Annual compliance section of label.

This section of label is only completed on low energy swing doors that comply with ANSI/BHMA A156.19 standard and pass inspection by a AAADM certified dormakaba USA Inc. technician.

4.2.4 Additional annual compliance inspection labels.

Place additional labels (Fig. 4.2.2) over annual compliance inspection section of safety information label.

Fig. 4.2.1 Low energy safety information label

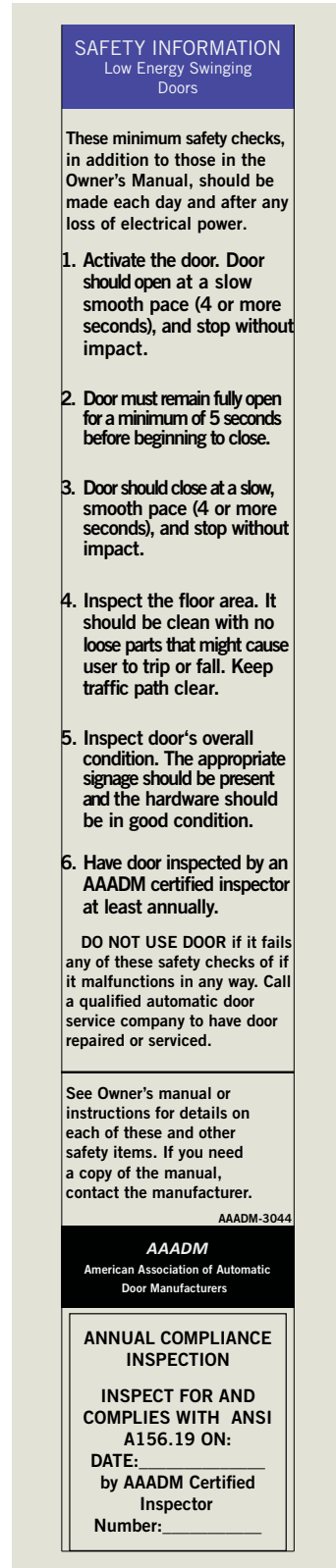
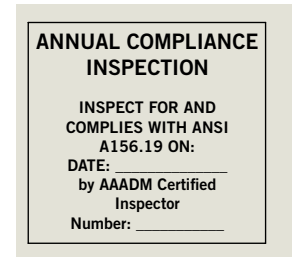

Fig. 4.2.2 Annual compliance inspection label



5 Daily safety check procedure

5.1 Full energy power operated swing door (ANSI/BHMA 156.10)

NOTICE

All figures and diagrams are for purposes of illustration only and are from AAADM power operated pedestrian door manual, reprinted with permission.

5.1.1 Performing daily safety checks.

Perform safety checks daily on your automatic swinging door to insure your customer and employee safety. The daily safety checks are listed in Chapter 4, AAADM safety information labels.



TIPS AND RECOMMENDATIONS

Perform these checks while traffic is restricted from all detection and sensing zones.

5.1.2 Sensor activation, safety sensor detection.

1. Check activation sensor by walking toward door opening at moderate speed, door should:
 - Start opening when you are about four feet from door.
 - Open smoothly.
 - Stop at fully open without impact.
2. Move slowly through door opening (approximately six inches/second) stop in door swing path, and pause for ten seconds.
 - Door should remain open.
3. If two way traffic, repeat from other side of door.
4. Step out of sensor zone activating area.
 - After a brief delay (minimum 1.5 seconds) door should close smoothly and without impact.
5. For one way traffic, approach safety side of door and have someone else approach activating side.
 - Door equipped with overhead mounted safety sensor (Fig 5.1.1), as long as you are in safety area of door it should not open.
 - Door equipped with door mounted safety sensors (Fig 5.1.2), door may start to open but should reverse, stop or slow down.
6. Stand motionless in door for at least 4 seconds.
 - Door equipped with overhead mounted presence sensor (Fig 5.1.1), door should not close.
 - Door equipped with door mounted safety sensors (Fig 5.1.2), door may start to close but should reverse, stop or slow down.

Fig. 5.1.1 One way traffic, overhead mounted safety sensor

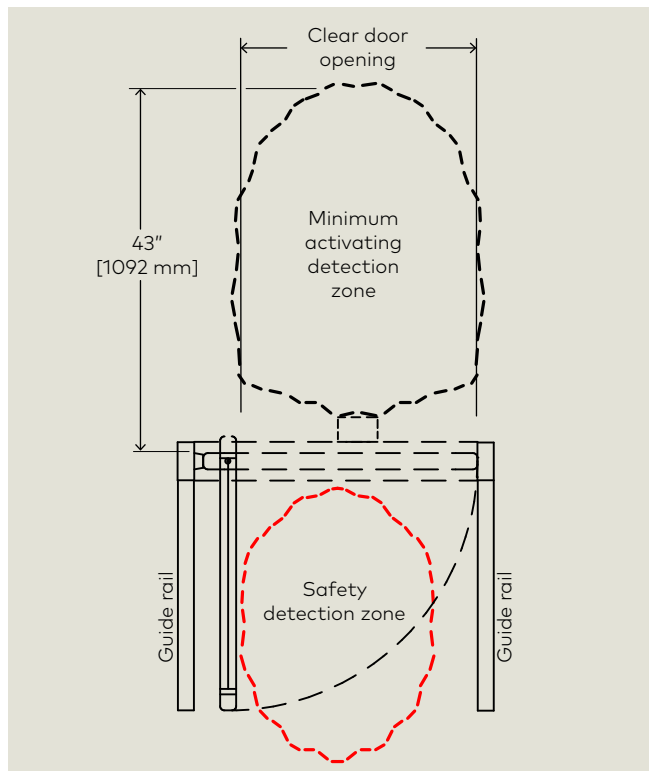
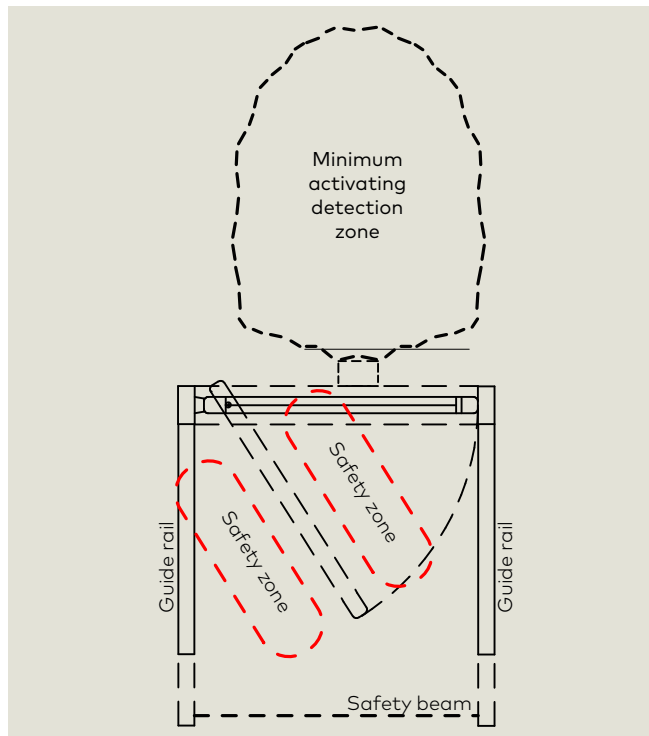

Fig. 5.1.2 One way traffic, door mounted safety sensors



5.2 Low energy power operated swing doors (ANSI/BHMA A156.19)

5.2.1 Performing daily safety checks.

Perform safety checks daily on your low energy swing door to insure your customer and employee safety. These daily safety checks are also listed in Chapter 4, Safety Information labels, low energy swinging doors.

1. Activate the door by a knowing act (Para.3.3).
 - Door should open at a slow smooth pace (4 seconds or more) and stop without impact.
2. Door must remain fully open for a minimum of 5 seconds before beginning to close.
 - Door should close at a slow smooth pace (4 seconds or more) and stop without impact.
3. Inspect the floor area, it should be kept clean with no loose parts that might cause user to trip or fall. Keep traffic path clear.
4. Inspect door's overall condition. The appropriate signage (Chapter 7) should be present and all hardware should be in good condition.
5. Have door inspected by a dormakaba USA Inc. AAADM certified technician at least annually.



WARNING

If there are any problems, discontinue door operation immediately and secure the door in a safe manner.
Call your local dormakaba USA Inc. distributor for repair.

Fig. 5.2.1 In-ground ED250 door (LH door with track and arm example)

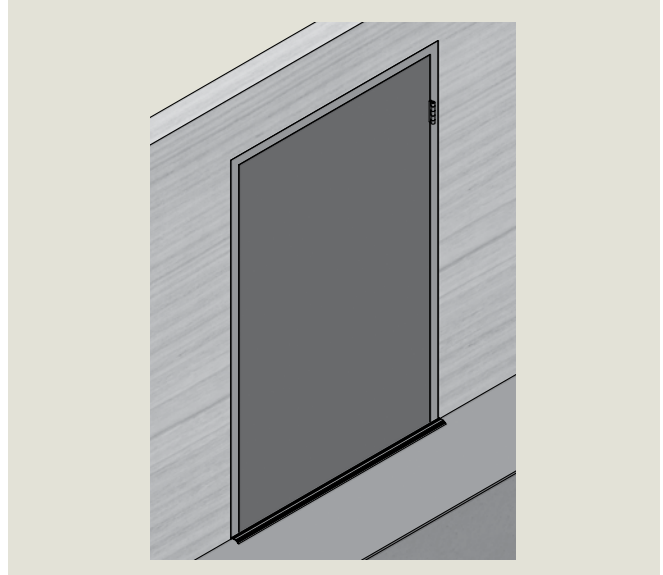

6 General safety related items

6.1 Full energy power operated swing doors (ANSI/BHMA 156.10)

6.1.1 Review safety related items and perform checks periodically as noted.



TIPS AND RECOMMENDATIONS

Perform these checks while traffic is restricted from all detection and sensing zones.

1. Housekeeping
 - Check door area for tripping or slipping hazards.
 - Check all doors for damage.
 - Make sure all hardware and overhead covers are properly secured.
 - There should be no bulletin boards, literature racks, merchandise displays, or other attractions in the door area that would interfere with the use of the door or encourage people to stop and stand in the door area.
2. Door closing force
 - Force to prevent the door from closing should not exceed 30 pounds measured with a force gauge.
3. Door safety signage
 - Refer to Chapter 7 for door safety signage requirements.
 - Refer to Chapter 4 for Safety Information labels.
4. Activating switch, knowing act (Para. 3.3)
 - Doors equipped with a manual activating switch shall hold door fully open for a minimum of five seconds before closing.
5. Guide rails (Fig. 6.1.1, 2), if used.
 - Check that guide rails or other barriers or separators are present (two per swing door side) and firmly anchored.
 - Rail lengths should be the width of the open door or greater.
6. Lock stile
 - With door open, grasp lock stile of door and attempt to move horizontally and vertically.
 - There should be no looseness in the door pivots or in connections between door and operator.
7. Breakout stop
 - Center pivoted in swinging doors may be supplied with an emergency breakout stop or switch that will allow the door to open in the direction of emergency egress.
 - When the door is pushed into the breakout mode, check that the door will not activate.

Fig. 6.1.1 Guide rails, jamb and floor mounted

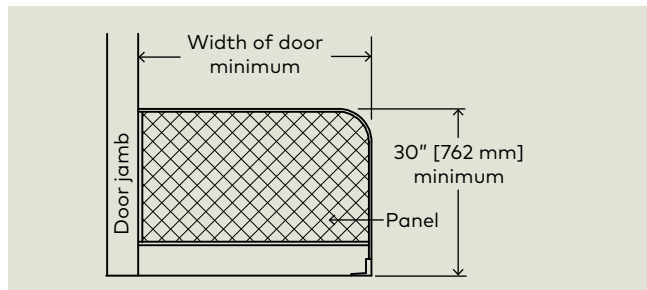
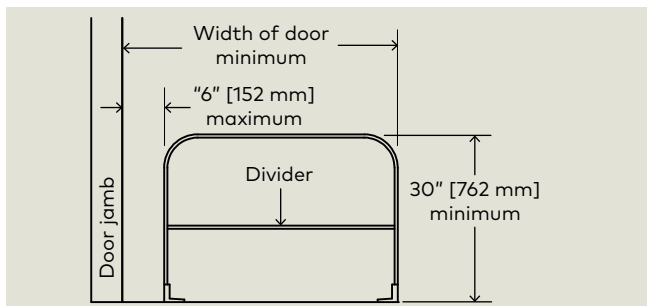

Fig. 6.1.2 Guide rails, free standing, floor mounted



8. Traffic patterns
 - Observe traffic patterns. Plan routing so people enter and exit in a straight approach, directly toward the door opening.
9. Finger guard
 - If installed, inspect finger guard to see that it is secure and in good repair.
10. AAADM safety information label (Chapter 4)
 - An AAADM safety information label should be affixed on the door or door frame in a protected, visible location.
 - If you need additional decals or labels, contact your local authorized dormakaba USA, Inc. distributor.



WARNING

If there are any problems, discontinue door operation immediately and secure the door in a safe manner. Call your local dormakaba USA, Inc. distributor for repair.

6.1 Low energy power operated swing doors (ANSI/BHMA 156.19)

6.1.1 Review safety related items and perform checks periodically as noted.



TIPS AND RECOMMENDATIONS

Perform these checks while traffic is restricted.

1. Housekeeping
 - Check door area for tripping or slipping hazards.
 - Make sure all door hardware is properly secured.
 - There should be no bulletin boards, literature racks, merchandise displays, or other attractions in the door area that would interfere with the use of the door or encourage people to stop and stand in the door area.
2. Check all doors for damage.
3. Door closing force.



TIPS AND RECOMMENDATIONS

Reference ANSI/BHMA A156.19 standard, power assist and low energy power operated doors.

- Force to prevent the door from closing should not exceed 15 pounds measured with a force gauge.
4. Door safety signage.
 - Refer to Chapter 7 for door safety signage requirements. Chapter 4 documents safety information (daily safety check) and annual compliance inspection labels requirements.
 5. Lock stile
 - With door open, grasp lock stile of door and attempt to move horizontally and vertically.
 - There should be no looseness in the door pivots or in connections between door and operator.
 6. Breakout stop
 - Center pivoted in swinging doors may be supplied with an emergency breakout stop or switch that will allow the door to open in the direction of emergency egress.
 - When the door is pushed into the breakout mode, check that the door will not activate.

7. AAADM safety information label (Chapter 4)
 - An AAADM safety information label should be affixed on the door or door frame in a protected, visible location.
 - If you need additional decals or labels, contact your local authorized dormakaba USA, Inc. distributor.



WARNING

If there are any problems, discontinue door operation immediately and secure the door in a safe manner.
Call your local dormakaba USA Inc. distributor for repair.

7 ED100/ED250 door signage

7.1 Full energy operator (ANSI/BHMA A156.10)

7.1.1 Overview

Signage and warnings are specified in ANSI /BHMA A156.10, American National Standard for Power Operated Pedestrian Doors, paragraph 11.

7.1.2 Door, one way traffic.

1. Arrow and AUTOMATIC DOOR, one side of decal (Fig. 13.1.1).
 - Shall be visible from approach side of a swinging door, mounted on door at a height of 50" ± 12" from floor to centerline of sign.
2. DO NOT ENTER and AUTOMATIC DOOR, one side of decal (or separate decal for solid doors - DD0739-020).
 - Shall be visible from non-approach side of door that swings towards pedestrians attempting to travel in wrong direction.

7.1.3 Door, two way traffic.

1. Arrow and AUTOMATIC DOOR, one side of decal.
 - Shall be visible from approach side of a swinging door, mounted on door at a height of 50" ± 12" from floor to centerline of sign.
2. CAUTION AUTOMATIC DOOR, one side of decal.
 - Swinging doors serving both egress and ingress shall have a "CAUTION AUTOMATIC DOOR" sign visible from swing side of door.
 - Sign shall be mounted on door at a height of 50 ± 12" from floor to centerline of sign.

7.1.4 Knowing act door.

1. ACTIVATE SWITCH TO OPERATE decal.
 - Knowing act doors shall have signage stating "ACTIVATE SWITCH TO OPERATE" on side of door having knowing act switch or other knowing act device.

Fig. 7.1.1 One decal, approach, non-approach

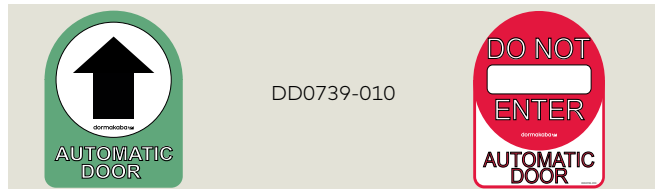

Fig. 7.1.2 One decal, non-swing side, swing side

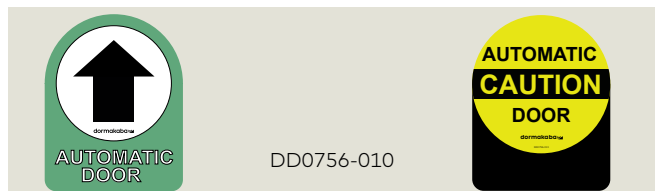

Fig. 7.1.3 ACTIVATE SWITCH TO OPERATE decal



7.2 Low energy operator (ANSI/BHMA 156.19)

7.2.1 Overview

Signage and warnings are specified in ANSI /BHMA A156.19, American National Standard for power assist and low energy power operated doors.

7.2.2 All low energy doors.

1. AUTOMATIC CAUTION DOOR decal.
 - All low energy doors shall be marked with signage visible from both side of door with the words "AUTOMATIC CAUTION DOOR".
 - Signs shall be mounted 50" ± 12" from floor to centerline of sign.

7.2.3 Knowing act switch used to initiate door operation.

1. ACTIVATE SWITCH TO OPERATE decal.
 - When a knowing act device is used to initiate operation of door operator, door shall be provided with sign on each side of door where switch is operated with message "ACTIVATE SWITCH TO OPERATE".

7.2.4 Push/Pull used to initiate door operation.

1. PUSH TO OPERATE, PULL TO OPERATE decals.
 - When push/pull is used to initiate operation of door operator, doors shall be provided with the message "PUSH TO OPERATE" on push side of door and "PULL TO OPERATE" on pull side of door.

Fig. 7.2.1 AUTOMATIC CAUTION DOOR decal



Fig. 7.2.2 ACTIVATE SWITCH TO OPERATE decal



- 1 Activate Switch to Operate DD0758-010

Fig. 7.2.3 PUSH TO OPERATE, PULL TO OPERATE decals



- | | |
|--|--|
| <ol style="list-style-type: none"> 2 Push to Operate DD0762-010 | <ol style="list-style-type: none"> 3 Pull to Operate DD0762-020 |
|--|--|

7.3 Door signage, low energy swing doors (ANSI/BHMA 156.19)

7.3.1 Single door

Fig. 7.3.1 Activate Switch To Operate

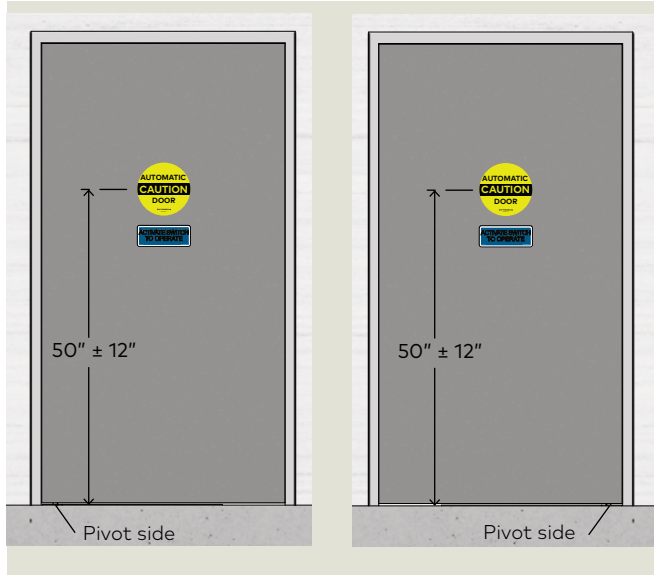
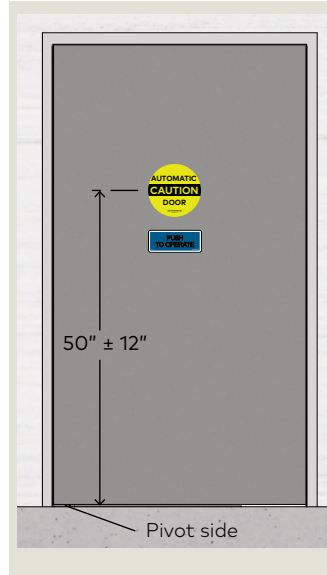
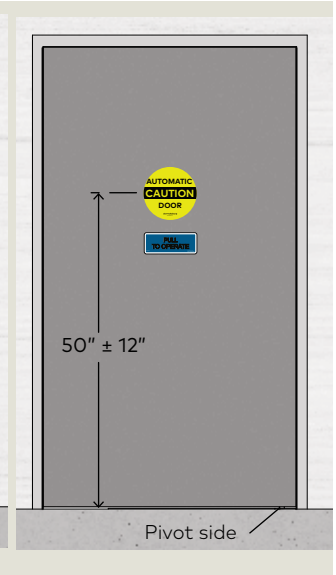

Fig. 7.3.2 Push/Pull Push To Operate



Pull To Operate



7.3.2 Double doors

Fig. 7.3.3 Activate Switch to Operate

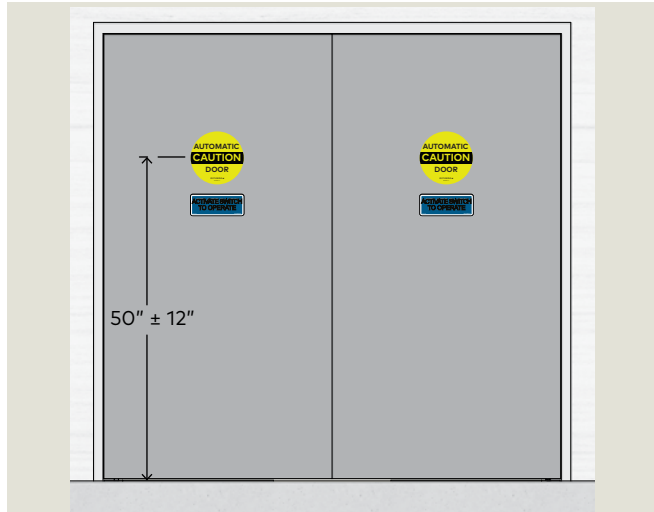

Fig. 7.3.4 Opposite side, no device

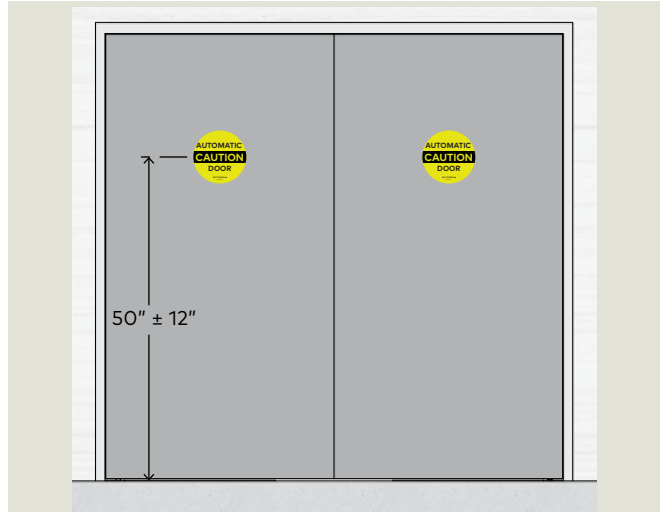

Fig. 7.3.5 Push/Pull, Pull side

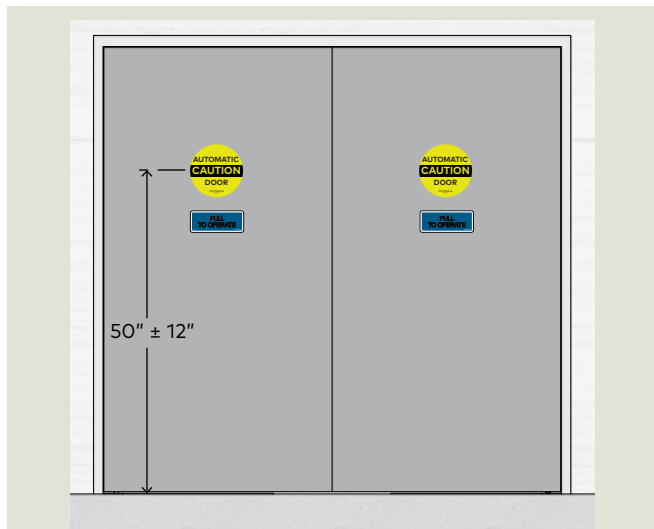
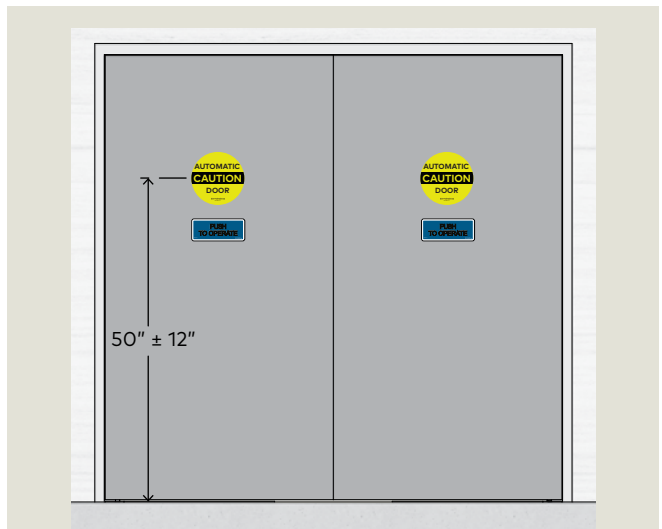
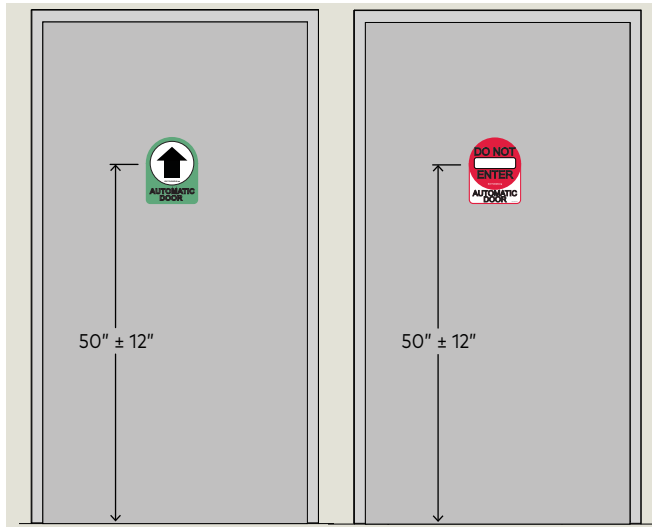

Fig. 7.3.6 Push/Pull, Push side



7.4 Door signage, full energy single swing doors (ANSI/BHMA A156.10)

Fig. 7.4.1 One way traffic
Approach side



Non-approach side

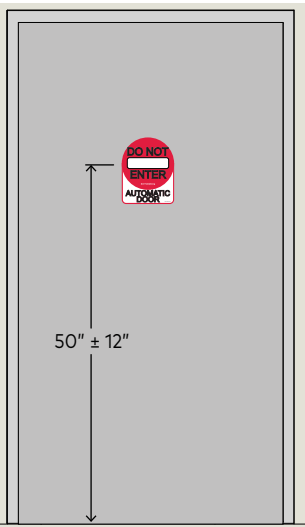
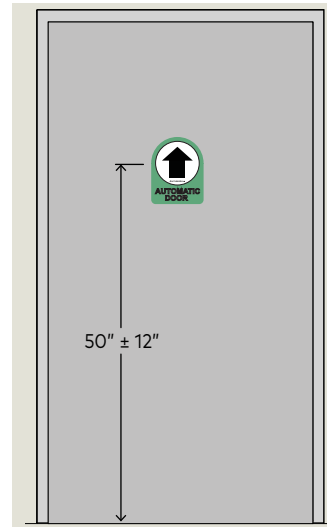
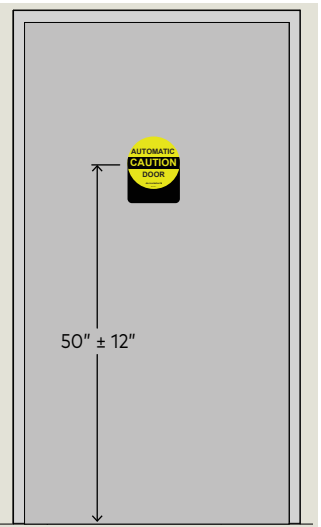

Fig. 7.4.2 Two way traffic
Non swing side



Swing side



7.5 Door signage, full energy double swing doors (ANSI/BHMA A156.10)

Fig. 7.5.1 One way traffic, approach side

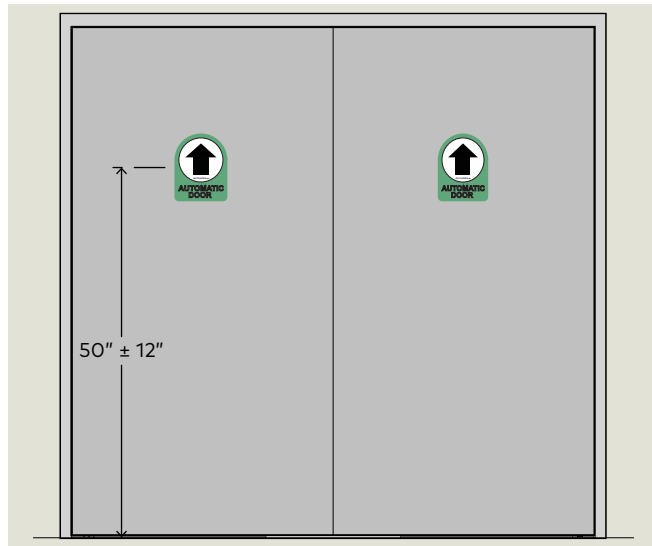

Fig. 7.5.2 One way traffic, non approach side

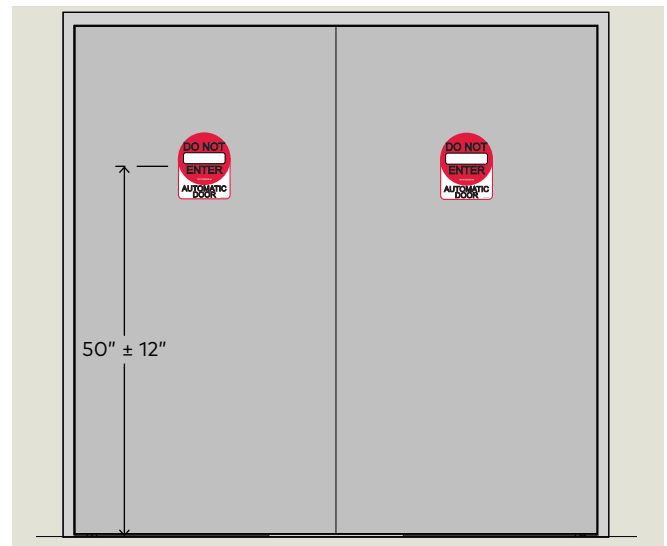

Fig. 7.5.3 Two way traffic, non swing side

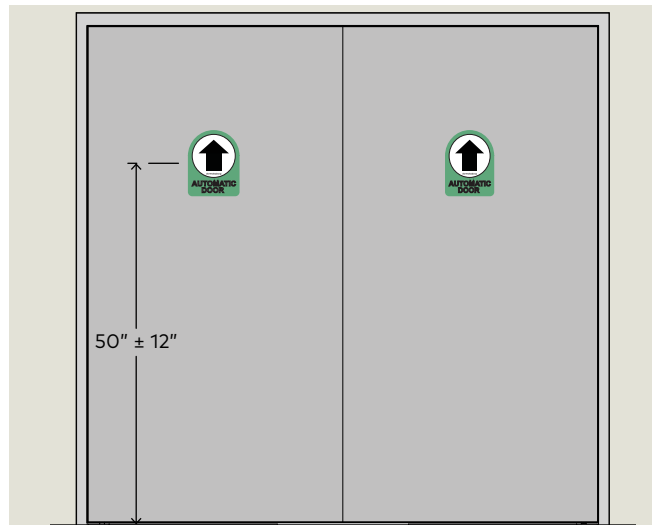
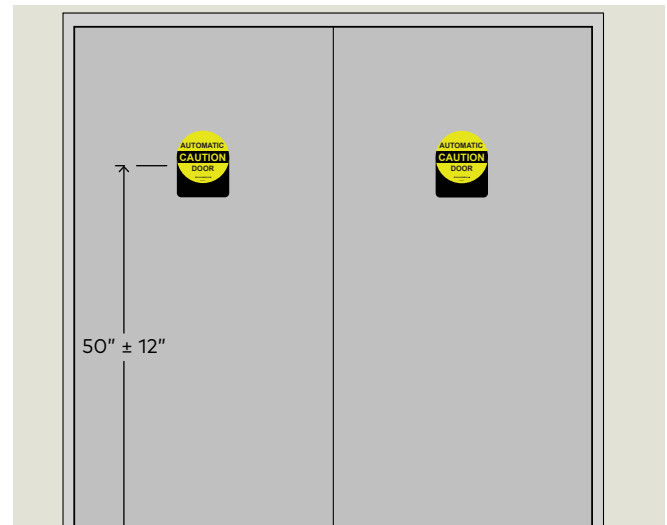

Fig. 7.5.4 Two way traffic, swing side



8 ED250 in-ground door threshold

8.1 Install door threshold

Fig. 8.1.1 Threshold example for ED250 in-ground

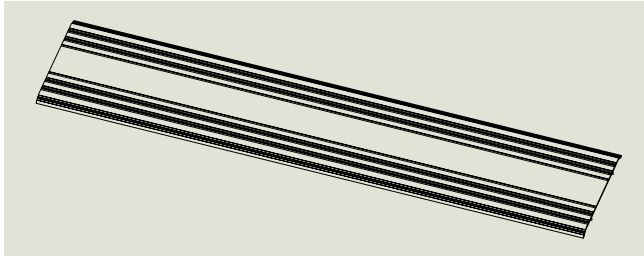

Fig. 8.1.2 Door threshold installation example for ED250 in-ground

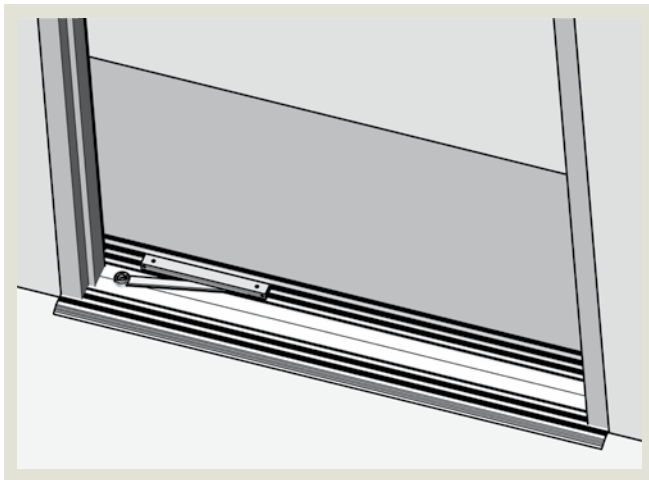
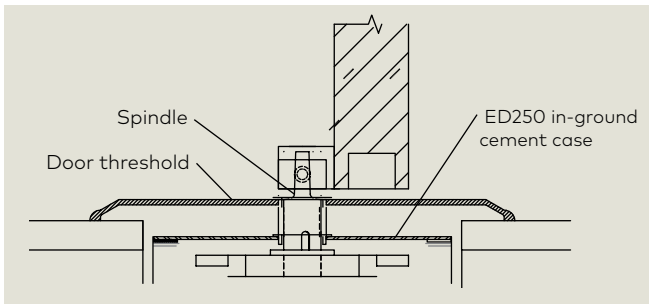

Fig. 8.1.3 Threshold installation end view example



NOTICE

Door threshold installation and maintenance is owner's responsibility

8.1.1 Door threshold seal at spindle.

CAUTION

Spindle opening at threshold must be sealed with an O-ring or similar device.

8.1.2 Door threshold perimeter seal.

CAUTION

Threshold perimeter must be sealed with a silicone sealant.

8.1.3 Cleaning door threshold and floor area around threshold.

CAUTION

Do not pressure wash door threshold or floor area adjacent to door threshold!



WARNING

Access to the ED250 in-ground system must only be done by dormakaba USA Inc. certified technicians!

This page left intentionally blank.

